



OxiMAX N-600x™

Pulse Oximeter
with
Alarm Management System

Service Manual



To Purchase, Visit Avobus.com or call [1-800-674-3655](tel:1-800-674-3655)

Nellcor, Durasensor, Dura-Y, Max-Fast, OxiCliq, Oxiband, OxiMax, Oxinet, Pedi-Check, SatSeconds, OxiMax SPD Alert, and SoftCare are trademarks of Nellcor Puritan Bennett LLC.

The OxiMax N-600x™ pulse oximeter is covered by one or more of the following U.S. patents and foreign equivalents: Patent No. 5,485,847; 5,676,141; 5,743,263; 6,035,223; 6,226,539; 6,411,833; 6,463,310; 6,591,123; 6,708,049; 7,016,715; 7,039,538; 7,120,479; 7,120,480; 7,142,142; 7,162,288; 7,190,985; 7,194,293; 7,209,774; 7,212,847.

To obtain information about a warranty, if any, contact Nellcor's Technical Services Department at 1.800.635.5267 or your local Nellcor representative.

Purchase of this instrument confers no express or implied license under any Nellcor Puritan Bennett patent to use the instrument with any sensor that is not manufactured or licensed by Nellcor Puritan Bennett LLC.

Table of Contents

Chapter 1.	Safety Information.....	9
	Overview.....	9
	Warnings.....	9
	Cautions.....	11
Chapter 2.	General Introduction.....	13
	Overview.....	13
	Related Documents.....	13
	Oximeter Description and Intended Use.....	13
	Description.....	13
	Intended Use.....	14
	List of Components.....	15
	Front Panel.....	16
	User Interface.....	16
	Oximeter Visual Indicators.....	17
	Monitoring Values.....	19
	Audible Indicators.....	20
	Rear Panel.....	21
	Rear Panel Symbols and Descriptions.....	21
	Oximeter Features.....	22
	OxiMax SPD™ Alert Feature.....	22
	SatSeconds™ Alarm Management Feature.....	22
	Pulse Rate Delay Alarm Management Feature.....	26
	Oximeter Display View Options.....	26
	Selecting Display Views.....	26
	General Care Format (GCF) Display.....	26
	Plethysmographic (Pleth) Display.....	27
	Blip Display.....	27
	Real-Time Trend Display.....	27
Chapter 3.	Product Specifications.....	29
	Overview.....	29
	Physical Characteristics.....	29
	Electrical Requirements.....	29
	Power.....	29
	Battery.....	29
	Rating of Nurse Call Relay.....	30
	Environmental Conditions.....	30
	Operating.....	30
	Transport and Storage.....	30
	Performance Specifications.....	30
	Measurement Range.....	30
	OxiMax™ Pulse Oximetry Sensors.....	31
	Product Compliance.....	32

	Product Standards for Compliance	32
	Product Safety Standards	32
	Electromagnetic Compatibility (EMC) Standards	32
	Manufacturer's Declaration	32
	Basics	32
	Electromagnetic Compatibility (EMC).....	33
	Electromagnetic Immunity	33
	Sensor and Cable Compliance	35
	Safety Tests.....	36
	Ground Integrity	36
	Leakage Current.....	37
Chapter 4.	Theory of Operations	39
	Overview.....	39
	Understanding Pulse Oximetry.....	39
	Theoretical Principles	39
	Automatic Calibration.....	40
	Functional versus Fractional Saturation	40
	Measured versus Calculated Saturation	40
	Oximeter Features.....	41
	SatSeconds™ Alarm Management Feature	41
	Pulse Rate Delay Alarm Management Feature.....	41
	OxiMax SPD™ Alert Feature.....	42
	OxiMax™ Pulse Oximetry Sensor Technology	42
	Functional Testers and Patient Simulators.....	43
Chapter 5.	Product Overview.....	45
	Overview.....	45
	Oximeter Block Diagram.....	45
	System Board Components.....	46
	System Board Component Overview	46
	Secondary Input Port/Secondary Output Port (SIP/SOP).....	46
	NELL-1A Oximetry Module	46
	User Interface (UIF).....	47
	Power	47
	Pulse Oximetry Sensors and Cables	48
Chapter 6.	Setting Up the Oximeter.....	49
	Safety Reminders.....	49
	Connecting to an AC Power Source	50
	Using Battery Power	51
	Overview.....	51
	Connecting an OxiMax™ Pulse Oximetry Sensor	53
	Reducing EMI (Electromagnetic Interference).....	54



Chapter 7.	Operating the Oximeter.....	55
	Overview.....	55
	Monitoring Oximeter Power.....	55
	Battery Fuel Gauge.....	55
	Low Battery Indicator.....	56
	Powering the Oximeter.....	57
	Power Prerequisites.....	57
	Power-On Self-Test (POST).....	57
	Automatic Shutdown and Power Off.....	59
	Using OxiMax™ Pulse Oximetry Sensors.....	59
	Sensor Detection.....	60
	Sensor Detection Failure.....	61
	Managing the Oximeter Backlight.....	61
	Managing the View Display.....	62
	Adjusting the Volume of Audible Tones.....	62
	Adjusting the Pulse Beep Volume.....	62
	Managing Oximeter Alarms.....	62
	Managing Audible Alarms.....	63
	Using Oximeter Softkey Menus.....	64
	Navigating Menu Options.....	64
	Adjusting the Factory Default Settings.....	72
	Using the OxiMax SPD™ Alert Feature.....	77
	Using the Pulse Rate Delay Alarm Management Feature.....	78
	Using the SatSeconds™ Alarm Management Feature.....	78
Chapter 8.	Managing the Data Port.....	79
	Managing Oximeter Trend Data.....	79
	Data Port Connectivity.....	79
	Overview.....	79
	Data Port Requirements.....	79
	Data Port Communications.....	81
	Accessing Data Using the Comm Port and a Computer.....	83
	Configuring the Data Port Interface.....	84
	Communication Protocol.....	84
	Managing the Data Port.....	86
	Data Printout Information.....	86
	Using the Nurse Call Interface.....	93
	Nurse Call Feature.....	93
	Setting Nurse Call RS-232 Polarity.....	94
	Calculating the Analog Voltage Output.....	94
Chapter 9.	Performance Considerations.....	97
	Overview.....	97
	Performance Considerations.....	97
	Primary Considerations.....	97
	Oximetry Considerations.....	98

	Patient Conditions	98
	OxiMax™ Pulse Oximetry Sensor Performance Considerations	98
	Safety Information	98
	Inaccurate Sensor Measurement Conditions	99
	Signal Loss	99
	Recommended Usage	99
Chapter 10.	Oximeter Preventive Maintenance	101
	Overview	101
	Cleaning	101
	Periodic Safety Checks	101
Chapter 11.	Modifying and Testing the Oximeter	103
	Overview	103
	Setting Institutional Defaults (Sample)	103
	Performance Verification	105
	Overview	105
	Required Equipment	105
	Safety Testing Standards	106
	Battery Check	106
	Battery Power	106
	Battery Charge	106
	Performance Tests	107
	Power-On Defaults and Alarm Ranges	107
	Operational Setup	110
	Overall Performance Check	115
	Pulse Oximetry Functional Tests	117
	Setting Nurse Call	130
	Service Function Menus	130
Chapter 12.	Troubleshooting	137
	Overview	137
	Help and Support	137
	Technical Services	137
	On-Screen Help	137
	Problem Resolution	140
	Prompts, Error Messages, and Error Codes	141
	Prompts and Error Messages	141
	Error Codes	144
	Error Codes for Non-correctable Failures	146
	Power	152
	Keys	153
	Display/Alarms	153
	Operational Performance	154
	Data Port	154
	Primary Speaker Failure	155
	Low and Critical Battery Conditions	156

	Obtaining Technical Assistance.....	159
	Returning your Oximeter	159
Chapter 13.	Ordering Oximeter Spare Parts	161
	Overview.....	161
	Ordering Replacement Parts	161
	Spare Parts List	162
Chapter 14.	Repairing the Oximeter	165
	Overview.....	165
	Fuse Replacement.....	166
	Oximeter Disassembly and Reassembly.....	167
	Disassembling the Oximeter	167
	Reassembling the Oximeter	169
	Battery Replacement.....	170
	Removing the Old Battery	170
	Replacing the Battery.....	171
	Power Entry Module (PEM) Replacement	172
	Removing the Power Entry Module	172
	Replacing the Power Entry Module.....	173
	Power Supply Replacement	174
	Removing the Power Supply	174
	Replacing the Power Supply.....	175
	Cooling Fan Replacement.....	176
	Removing the Cooling Fan	176
	Replacing the Cooling Fan	176
	Display PCB Replacement.....	177
	Removing the Display PCB.....	177
	Replacing the Display PCB	178
	Main Board PCB Replacement.....	179
	Removing the Main Board PCB	179
	Replacing the Main Board PCB.....	180
	Alarm Speaker Replacement	181
	Removing the Alarm Speaker.....	181
	Replacing the Alarm Speaker	182
	Top Case Assembly Replacement	183
	Removing the Top Case Assembly.....	183
	Replacing the Top Case Assembly	183
	Packing the Oximeter for Shipment.....	184
	Shipment Requirements.....	184
	Using the Original Carton.....	184
	Using a Generic Carton.....	185
Chapter 15.	Oximeter Schematics.....	187



1 Safety Information

Overview

This section contains safety information requiring users to exercise appropriate caution while using the OxiMax N-600x™ pulse oximeter.



Warnings are identified by the WARNING symbol shown above.

Warnings alert you to potential serious outcomes (death, injury, or adverse events) to the patient or user.



Cautions are identified by the CAUTION symbol shown above.

Cautions alert the user to exercise care necessary for the safe and effective use of the OxiMax N-600x pulse oximeter.



Notes are identified by the NOTE symbol shown above. Notes are listed before or after procedural steps or information and provide additional guidelines or information on the subject being described.

Warnings



WARNING

Only qualified service personnel should open the oximeter housing, remove and replace components, or make adjustments. If your medical facility does not have a qualified service technician, please contact Nellcor's Technical Services or your local Nellcor representative.



WARNING

Before attempting to open or disassemble the oximeter, disconnect the power cord to avoid possible injury.



WARNING

The OxiMax pulse oximetry sensor extrapolates from the date and time provided by the Nellcor OxiMax N-600x pulse oximeter when recording the sensor event record to the sensor. The accuracy of the date/time is determined by the date/time setting of the pulse oximeter. Set the pulse oximeter date and time to the correct value before connecting a record-enabled sensor to keep the date and time consistent for as long as the sensor remains connected. Since a sensor with sensor event record data can be transported from one oximeter to another, having discrepancies in the date/time between oximeters and the sensor event record data will affect the order in which the sensor event record data appear. To eliminate this potential problem, set all oximeters within an institution to the same time.



WARNING

Explosion hazard—Do not use the OxiMax N-600x pulse oximeter in the presence of flammable anesthetics.



WARNING

Do not spray, pour, or spill any liquid on the OxiMax N-600x pulse oximeter, its accessories, connectors, switches, or openings in the chassis, since this may cause damage to the oximeter.



WARNING

Supplemental oxygen will attenuate patterns of desaturation. A patient's respiratory compromise can be proportionally more severe before patterns appear in the saturation trend. Remain vigilant when monitoring a patient on supplemental oxygen.



WARNING

The LCD panel contains toxic chemicals. Do not touch broken LCD panels. Physical contact with a broken LCD panel can result in transmission or ingestion of toxic substances.



WARNING

Do not silence or decrease the volume of the OxiMax N-600x pulse oximeter's audible alarm if patient safety could be compromised.



WARNING

Failure to cover the OxiMax pulse oximetry sensor site with opaque material in high ambient light conditions may result in inaccurate measurements. Pulse oximetry readings and pulse signals can be affected by certain environmental conditions, OxiMax pulse oximetry sensor application errors, and certain patient conditions. See the appropriate sections of this manual for specific safety information.



WARNING

The use of accessories, sensors, and cables other than those specified may result in inaccurate readings of the OxiMax N-600x pulse oximeter and increased emission and/or decreased electromagnetic immunity of the oximeter.

**WARNING**

When installing the pulse oximeter's AC power cord, ensure the cord is carefully positioned to prevent tripping and entanglement.

Cautions

**Caution**

Observe standard ESD (electrostatic discharge) precautions when disassembling, reassembling, and when handling any of the components of the oximeter.

**Caution**

When installing the OxiMax N-600x pulse oximeter power supply or the Main Board PCB, tighten the seven screws (4-in lbs. maximum). Overtightening could strip out the screw holes in the bottom case, rendering it unusable.

**Caution**

When reassembling the OxiMax N-600x pulse oximeter, tighten the screws that hold the cases together (10-in lbs. maximum). Overtightening could strip out the screw holes in the top case, rendering it unusable.

**Caution**

Signal artifact, secondary to a variety of external factors, may compromise the presence or accuracy of the displayed oximeter values.

**Caution**

When connecting the OxiMax N-600x pulse oximeter to any instrument, verify proper operation before clinical use. Both the pulse oximeter and the instrument connected to it must utilize a grounded outlet. Accessory equipment connected to the pulse oximeter's data interface must be certified according to IEC Standard 60950 -1: 2005 for data-processing equipment or IEC Standard 60601-1:1988 + A1:1991 + A2:1995 for electromedical equipment. All combinations of equipment must be in compliance with IEC Standard 60601-1-1:2000 Requirements for Medical Electrical Systems. Anyone connecting additional equipment to the signal input port or signal output port (data port connector) is configuring a medical system and, therefore, is responsible for ensuring that the system complies with the Requirements for Medical Electrical Systems IEC Standard 60601-1-1:2000 and the electromagnetic compatibility IEC Standard 60601-1-2:2001 + A1:2004. Oximeter accuracy may degrade if it is connected to secondary I/O devices when the equipment is not connected to earth reference.

**Caution**

Federal law (U.S.A.) restricts this device to sale by or on the order of a physician.

**Caution**

Dispose of battery in accordance with local requirements and regulations.

2 General Introduction

Overview



WARNING

The OxiMax N-600x pulse oximeter is intended only as an adjunct in patient assessment. It must be used in conjunction with clinical signs and symptoms.

The *N-600x Service Manual* contains information for servicing the OxiMax N-600x™ pulse oximeter. Only qualified service personnel should service this product. Before servicing the oximeter, thoroughly read the *N-600x Operator's Manual* for safe operation. The latest version of this manual is available on the Internet at:

<http://www.nellcor.com/serv/manuals.aspx>

Related Documents

Before servicing the OxiMax N-600x pulse oximeter, read the *N-600x Operator's Manual*. This will provide you with a basic understanding of the OxiMax N-600x pulse oximeter principles of operation. This knowledge is essential in performing tests and using circuit analysis sections to maintain the oximeter and troubleshoot oximeter errors or malfunctions

Before attaching any of the various Nellcor approved OxiMax pulse oximetry sensors to the oximeter, refer to the individual *Directions for Use (DFU)* and the *OxiMax Sensor Accuracy Grid (SAG)*.

The *N-600x Operator's* and *N-600x Service Manuals* are posted on the Internet at:

<http://www.nellcor.com/serv/manuals.aspx>

A Spare Parts and Accessories list is also posted on the Internet at:

<http://www.nellcor.com>

Oximeter Description and Intended Use

Description

The OxiMax N-600x pulse oximeter provides continuous noninvasive monitoring of functional oxygen saturation of arterial hemoglobin (SpO₂) and pulse rate. With the

proper firmware, activation of the pulse oximeter's OxiMax SPD™ Alert (SPD) feature is possible.

Intended Use

The OxiMax N-600x pulse oximeter is intended for prescription use only with neonatal, pediatric, and adult patients who are well or poorly perfused in hospitals, hospital-type facilities, intra-hospital transport, and home environments. The OxiMax SPD™ Alert (SPD) feature is intended only for facility-use care of adults to detect patterns of desaturation indicative of repetitive reductions in airflow through the upper airway and into the lungs.

Note:



Intended typical usage may be defined to include the following for the OxiMax N-600x pulse oximeter:

- Hospital use typically covers such areas as general care floors (GCFs), operating rooms, special procedure areas, intensive and critical care areas within the hospital and in hospital-type facilities. Hospital-type facilities include physician office-based facilities, sleep labs, skilled nursing facilities, surgicenters, and sub-acute centers.
- Intra-hospital transport includes transport of a patient within the hospital or hospital-type facility.
- Homecare use involves a lay person (parent or other similar non-critical caregiver) in the home environment.

Use with any particular patient requires the selection of an appropriate OxiMax pulse oximetry sensor.

Through the use of the four softkeys, users can access trend information, change alarm limits, adjust the internal time clock, select the communications protocol, and choose the interface language native to the language of the facility, caregiver, or user. See *Using Oximeter Softkey Menus*, page 64.

Figure 1. Front Panel Menu Softkeys

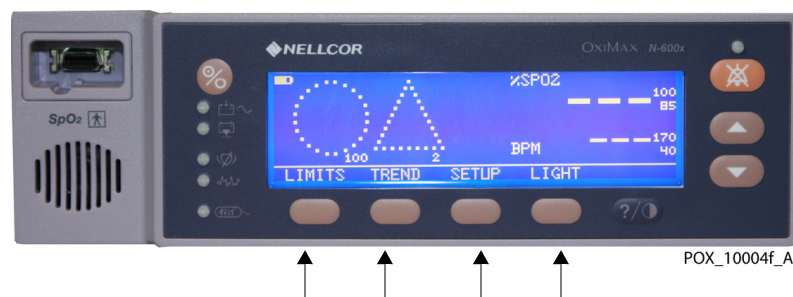

The oximeter can operate on AC power or on an internal battery. The controls and indicators for the oximeter are illustrated and identified in *OxiMax N-600x Pulse Oximeter Front Panel*, Figure 2 on page 16 and *OxiMax N-600x Pulse Oximeter Rear Panel*, Figure 3 on page 21.

List of Components

The typical OxiMax N-600x pulse oximeter carton ships with the following packing list of contents.

Table 1. Typical Packing List

Quantity	Item
1	OxiMax N-600x pulse oximeter
1	Nellcor OxiMax pulse oximetry sensor or assortment pack
1	DOC-10 pulse oximetry cable
1	<i>N-600x Operator's Manual</i> (applicable to country of sale) and/or compact disc
1	Hospital-grade power cord (applicable to country of sale)
2	Fuses, 0.5 A, 250 volts, slow-blow, IEC (5 x 20 mm)
1	<i>N-600x Quick Guide</i>

Front Panel

Figure 2. OxiMax N-600x Pulse Oximeter Front Panel



Table 2. List of Front Panel Components

1 SpO2 Sensor Port	14 ADJUST UP & DOWN Keys
2 Low Battery Indicator	15 Pulse Rate (BPM) Upper Limit Value
3 AC Power Indicator	16 Pulse Rate (BPM) Lower Limit Value
4 ON/STANDBY Key	17 Neonate Mode Icon
5 Battery Fuel Gauge	18 HELP/CONTRAST Key
6 SatSeconds™ Icon & Limit Value	19 Fast Response Mode Icon
7 SPD Icon & Sensitivity Value	20 Pulse Rate (BPM)
8 Blip Bar	21 Menu Selection Softkeys
9 %SpO2 Real-time Value	22 Menu Bar
10 %SpO2 Upper Limit Value	23 Data In-Sensor Indicator
11 %SpO2 Lower Limit Value	24 Interference Indicator
12 Alarm Silence Indicator	25 Pulse Search Indicator
13 ALARM SILENCE Key	26 Oximeter Speaker

User Interface



Note:

Pressing a key, except the ON/STANDBY key, should result in either a valid or an invalid tone. If the key pressed fails to emit a tone, contact a qualified service technician.



ON/STANDBY Key—Use to turn the oximeter on and off



ALARM SILENCE Key—Use to silence ANY current alarms for the alarm silence duration period. After silencing an alarm, press the key again to reactivate the alarm. Additionally, use it to view and adjust alarm silence duration and alarm volume. The ALARM SILENCE key clears “SENSOR OFF,” “LOW BATTERY,” and “SENSOR DISCONNECT”

messages from the display. It lights continuously when an audible alarm has been silenced. It flashes when the alarm silence duration has been set to OFF.



WARNING

Pressing **ALARM SILENCE** will keep **ALL** alarms from sounding for the alarm silence duration period.



WARNING

Should the caregiver silence an **SPD** alarm, this resets the index that tracks repetitive patterns of desaturation and silences **ALL** alarms.



Should the caregiver fail to clear a primary audible alarm within two (2) minutes, a secondary alarm with a unique pitch sounds.



ADJUST UP Key—Use to increase variable parameters of the oximeter.



ADJUST DOWN Key—Use to decrease variable parameters of the oximeter.







HELP/CONTRAST Key—Use to access the on-screen help or adjust the screen contrast.

- Press and release the HELP/CONTRAST softkey to launch on-screen help.
- Press and hold the HELP/CONTRAST softkey while simultaneously pressing the ADJUST UP and ADJUST DOWN softkeys to increase or decrease the contrast of the display screen.



Softkey Menu Bar—Use to display the current softkey menu functions.

Oximeter Visual Indicators

-  **AC Power Indicator**—Lights continuously when connected to an AC power source and also shows when the battery is charging. Does not light when the oximeter is running on the internal battery.
-  **Low Battery Indicator**— Lights continuously when 15 or fewer minutes of battery capacity remain, then flashes when the battery capacity reaches a critically low condition.
-  **Pulse Search Indicator**—Lights continuously prior to initial acquisition of a pulse signal and during prolonged, challenging monitoring conditions. The pulse search indicator flashes during a loss-of-pulse signal.
-  **Interference Indicator**—Lights whenever the oximeter algorithm detects the incoming signal quality is degraded. An intermittently lit Interference Indicator is common during patient monitoring, and indicates the oximeter algorithm is dynamically adjusting the amount of data required for measuring SpO₂ and Pulse Rate. When lit continuously, the oximeter algorithm has extended the amount of data required for measuring SpO₂ and Pulse Rate. In this case, fidelity in tracking rapid changes in these values may be reduced.



Note:

Degradation can be caused by ambient light, poor sensor placement, electrical noise, electro-surgical interference, patient activity, or other causes.



Data In-Sensor Indicator—Lights to indicate that the attached OxiMax pulse oximetry sensor contains a patient sensor event record. The sensor event record information may be viewed or printed.



Battery Fuel Gauge—Displays the battery charge remaining on the oximeter. The battery fuel gauge consists of four bars, each corresponding to approximately 1.5 hours of operating time. All four bars are lit when the battery is fully charged. No bars are lit when a low battery condition exists. Visible in all display views. See *Battery Fuel Gauge Levels*, page 55.



Plethysmographic (pleth) Waveform—This non-normalized waveform uses real-time sensor signals, reflecting relative pulsatile strength and quality of incoming signals. This indicator is only available in the pleth display view.



Pulse Amplitude (blip bar)—Indicates pulse beat and the relative (non-normalized) pulse amplitude. As the detected pulse becomes stronger, more bars light with each pulse. This indicator is only available in the blip and general care format (GCF) display views.

%SpO2

81

%SpO2 Value—Indicates hemoglobin oxygen saturation levels. The display value flashes zeros during loss-of-pulse alarms and flashes the %SpO2 value when the SpO2 is outside the alarm limits. The oximeter continues to update the display during Pulse Search. Current upper and lower alarm limit settings appear as smaller values to the right of the dynamic %SpO2 value. Visible in all display views.

BPM

112

Pulse Rate Value—Displays the pulse rate in beats per minute. It flashes during loss-of-pulse alarms and when the pulse rate is outside of the alarm limits. During Pulse Search, the oximeter continues to update the display. Pulse rates outside of the pulse rate range of 20 to 250 bpm are displayed as 0 and 250, respectively. Current upper and lower alarm limit settings appear as smaller values to the right of the dynamic pulse rate value. Visible in all display views.

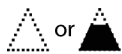

Saturation Pattern Detection (SPD) Icon—The OxiMax SPD™ Alert (SPD) feature detects patterns of desaturation in the SpO2 trend in adults. When the SPD feature is enabled, the oximeter detects patterns of desaturation indicative of repetitive reductions in airflow through a patient's upper airway into the lungs. When the SPD feature detects patterns of desaturation in the SpO2 trend in adults, caregivers are alerted to these patterns via a visual indicator, and optionally, an audio alarm. The triangle icon for OxiMax SPD™ Alert appears on the monitor display when the feature is enabled. The triangle fills from the bottom to the top as patterns become more severe. The triangle empties from top to bottom as the patterns become less severe. If the triangle fills, an alarm sounds. With Saturation Pattern Detection enabled, the default setting is On with the sensitivity set to 1. The feature can be turned off in the LIMITS menu. Caregivers can select from three alarm sensitivity settings: 1 (most sensitive), 2 (medium sensitivity) or 3 (least sensitive), with 1 resulting in more alarms and 3 resulting in fewer alarms. The rate at which the SPD icon fills depends on the SPD sensitivity setting. To explore activation, contact Nellcor's Technical Services Department at 1.800.635.5267 or your local Nellcor representative. To use the feature, reference the *N-600x Operator's Manual*.

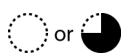

SatSeconds Icon—The SatSeconds feature provides alarm management for mild or brief SpO₂ limit violations. When the SatSeconds feature is enabled, the SatSeconds circle icon fills in the clockwise direction as the SatSeconds alarm management system detects SpO₂ readings outside of the limit setting. The SatSeconds icon empties in counterclockwise direction when SpO₂ readings are within limits. When the SatSeconds icon reaches full, a medium priority alarm sounds. Visible in all display views. For more information about using the feature, reference the *N-600x Operator's Manual*.



Fast Response Mode Icon—Appears at bottom right of the menu bar when enabled. The oximeter algorithm responds to changes in the SpO₂ data at differing rates: two to four seconds in Fast Mode and five to seven seconds in Normal Mode when calculating %SpO₂. The response mode setting does not affect the algorithm's calculation of pulse rate, nor does it influence the recording of trend data, which both occur at one-second intervals. The response mode, however, may impact the SPD alarm behavior. Visible in all display views when enabled. For more information about using the feature, reference the *N-600x Operator's Manual*.



Neonate Mode Icon—Appears at the bottom far right of the menu bar when enabled. Visible when the alarm limits are set to neonate limit values, but not when set to adult limit values. For more information about using the feature, reference the *N-600x Operator's Manual*.

Monitoring Values



WARNING

Failure to cover the OxiMax pulse oximetry sensor site with opaque material in high ambient light conditions may result in inaccurate measurements.

The OxiMax N-600x pulse oximeter continuously assesses the quality of the pulse oximetry signal while monitoring patient SpO₂ and pulse rate. Oximeter front panel values reflect the data derived from monitoring.

The N-600x pulse oximeter algorithm automatically extends the amount of data required for measuring SpO₂ and pulse rate depending on the measurement conditions.

- **Normal conditions**—During normal measurement conditions the averaging time is six to seven seconds (approximately three seconds in Fast Mode).
- **Brief abnormal conditions**—During conditions such as those caused by low perfusion, interference (e.g., external interference like ambient light), or a combination of these, the oximeter automatically extends the amount of data required beyond seven seconds. If the resulting dynamic averaging time exceeds 20 seconds, the pulse search indicator is lit solid and %SpO₂ and Pulse Rates update every second.
- **More severe conditions**—As these conditions extend, the required amount of data continues to increase. If the dynamic averaging time reaches 40 seconds, the pulse search indicator flashes to denote a loss-of-pulse condition and %SpO₂ and pulse rate flash values of zero. This activates the audible alarm state.

Audible Indicators

Audible indicators include pitched tones and beeps. Caregivers may choose to silence alarms by pressing the ALARM SILENCE key.



WARNING

Pressing ALARM SILENCE will keep ALL alarms from sounding for the alarm silence duration period.



Caution

Should the caregiver fail to clear a primary audible alarm within two (2) minutes, a secondary alarm with a unique pitch sounds.

Table 3. Audible Indicator Functions

Function	Description
Alarm Silence Reminder	Three beeps sound approximately every three minutes with the alarm silence duration set to OFF and the alarm silence reminder function enabled.
Piezo Tone	A high-pitched piezo tone sounds if there is no user response to an audible alarm, or if the oximeter detects a failure of the primary speaker.
Pulse Beep	Single beep sounds for each detected pulse. The pitch of the pulse beep signal changes with a point-by-point rise or fall in the saturation level.
High Priority Alarm	High-pitched, fast-pulsing tone indicates loss-of-pulse. Note: If a High Priority Alarm is not silenced within 30 seconds by pressing the ALARM SILENCE key, the oximeter increases the urgency level of the audible alarm signal by alternating a piezo tone with the primary alarm tone.
Medium Priority Alarm	Medium-pitched, pulsing tone indicates an SpO2 or pulse rate limit violation. Note: If a Medium Priority Alarm is not silenced within two minutes by pressing the ALARM SILENCE key, the oximeter increases the urgency level of the audible alarm signal by alternating a piezo tone with the primary alarm tone.
Low Priority Alarm	Low-pitched, slow-pulsing tone at 3.5 second intervals indicates an OxiMax pulse oximetry sensor disconnect, low battery, or oximeter failure. Note: If a Low Priority Alarm is not silenced within two minutes by pressing the ALARM SILENCE key, the oximeter increases the urgency level of the audible alarm signal by alternating a piezo tone with the primary alarm tone.
SPD Alarm	A trio of quick high-, medium-, high-pitched tones at 2.5 second intervals
High Alarm	A pair of quick medium-pitched tones followed by a high-pitched pulsing tone at 2.5 second intervals
Power-On Self-Test Pass	One-second tone indicates the oximeter has been turned on and has successfully completed the power-on self-test.
Confirmation Tone	Three beeps sound to confirm default settings are either saved or reset to factory defaults, or the trend data has been deleted.
Invalid Softkey Press	Quick, low-pitched tone indicates a softkey has been pressed that is inappropriate for the current state of the oximeter.
Valid Softkey Press	Quick, medium-pitched tone indicates appropriate softkey has been pressed.
Volume Setting Tone	Continuous tone indicates alarm volume adjustment.

Rear Panel

Figure 3. OxiMax N-600x Pulse Oximeter Rear Panel

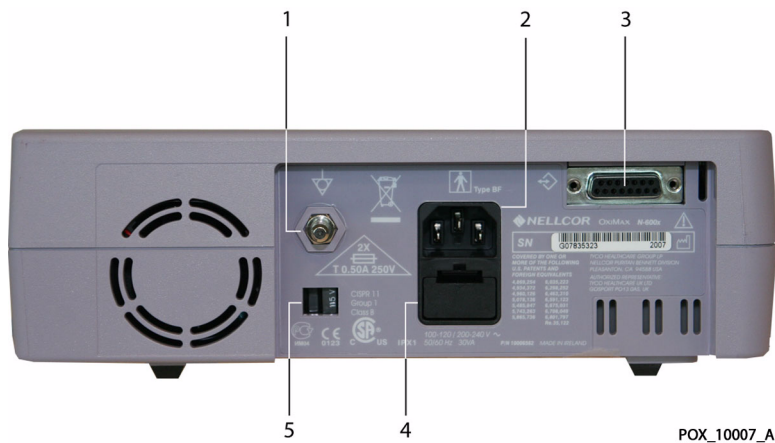

Table 4. Rear Panel Components

1	Equipotential Terminal (Ground)
2	AC Power Connector
3	Data Port Connector
4	Fuse Holder
5	Supply Voltage Selector Switch

Rear Panel Symbols and Descriptions



Warning! See Instructions for Use



Fuse replacement



Equipotential terminal (ground)



Date of manufacture



Data interface



Proper WEEE Waste Disposal



Type BF applied part - Not defibrillator proof

Oximeter Features

OxiMax SPD™ Alert Feature

The OxiMax SPD™ Alert (SPD) feature detects patterns of desaturation in adults that are indicative of repetitive reductions in airflow through a patient's upper airway into the lungs. Relative reductions in a patient's minute ventilation over a period of time may cause a progressive drop in alveolar partial pressure of oxygen, leading to arterial desaturation. If these decreases in ventilation are repetitive, they generate distinct patterns in the saturation trend. Patterns of repetitive desaturation often develop gradually over time, increasing in severity. Detection of patterns indicates that a patient might be suffering progressively severe decrements in airflow that may increase in acuity if left untreated.

Patterns of desaturation are multiple, sequential occurrences of a desaturation followed by a resaturation. The SPD feature qualifies patterns of desaturation resulting from such repetitive reductions in airflow based on specific characteristics.

- The severity of the desaturation event (the depth of the desaturation during the event) and the extent of the following resaturation
- The regularity of the desaturation events (how often the pattern repeats)
- The slope of the desaturation/resaturation trends that form the events

The SPD feature qualifies these patterns of desaturation over a period of six (6) minutes. Depending on the sensitivity setting for SPD, patterns that persist may result in an SPD alarm, alerting the caregiver to the condition.

Figure 4. Clinically Significant Desaturation Patterns

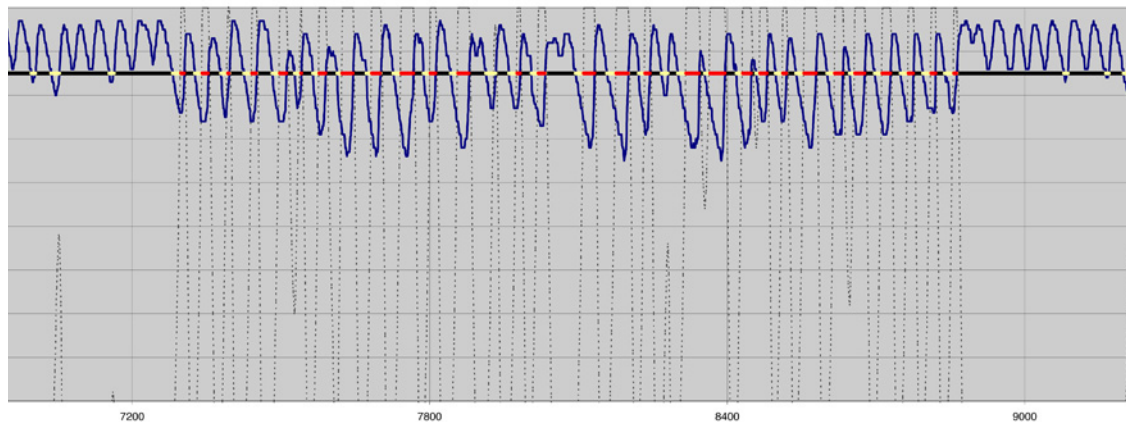

Reference the *N-600x Operator's Manual* for details.

SatSeconds™ Alarm Management Feature

The oximeter monitors the percentage of hemoglobin binding sites saturated with oxygen in the blood. With traditional alarm management, upper and lower alarm limits are set to alarm at specific SpO₂ levels. When the SpO₂ level fluctuates near an alarm limit, the alarm sounds each time it violates the alarm threshold. SatSeconds

monitors both degree and duration of desaturation as an index of desaturation severity. Thus, the SatSeconds feature helps distinguish clinically significant events from minor and brief desaturations that may result in nuisance alarms.

Figure 5. First Event: No SatSeconds Alarm

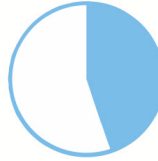

Event 1

The SatSeconds Alarm Limit is set at 25. The patient's SpO₂ drops to 79% and the duration of the event is 2 seconds before the saturation returns above the Low Alarm Limit of 85%.

6% drop below the Low Alarm Limit

x 2 second duration

12 SatSeconds

Because the SatSeconds Alarm Limit is set at 25 and the actual number of SatSeconds equals 12, there is no audible alarm.

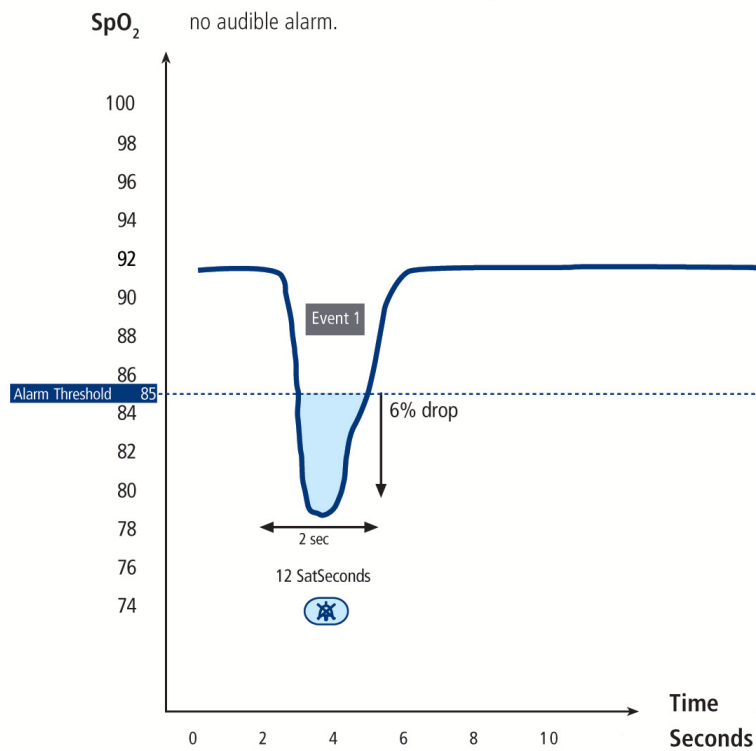

POX_10121_A

Figure 6. Second Event: No SatSeconds Alarm

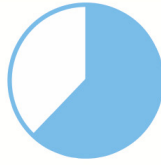

Event 2

The SatSeconds Alarm Limit is set at 25. The patient's SpO₂ drops to 84% and the duration of the event is 15 seconds before the saturation returns above the Low Alarm Limit of 85%.

1% drop below the Low Alarm Limit

X 15 second duration

15 SatSeconds

The total SatSeconds for this event are 15; therefore, no audible alarm will be heard because the SatSeconds alarm limit is set at 25.

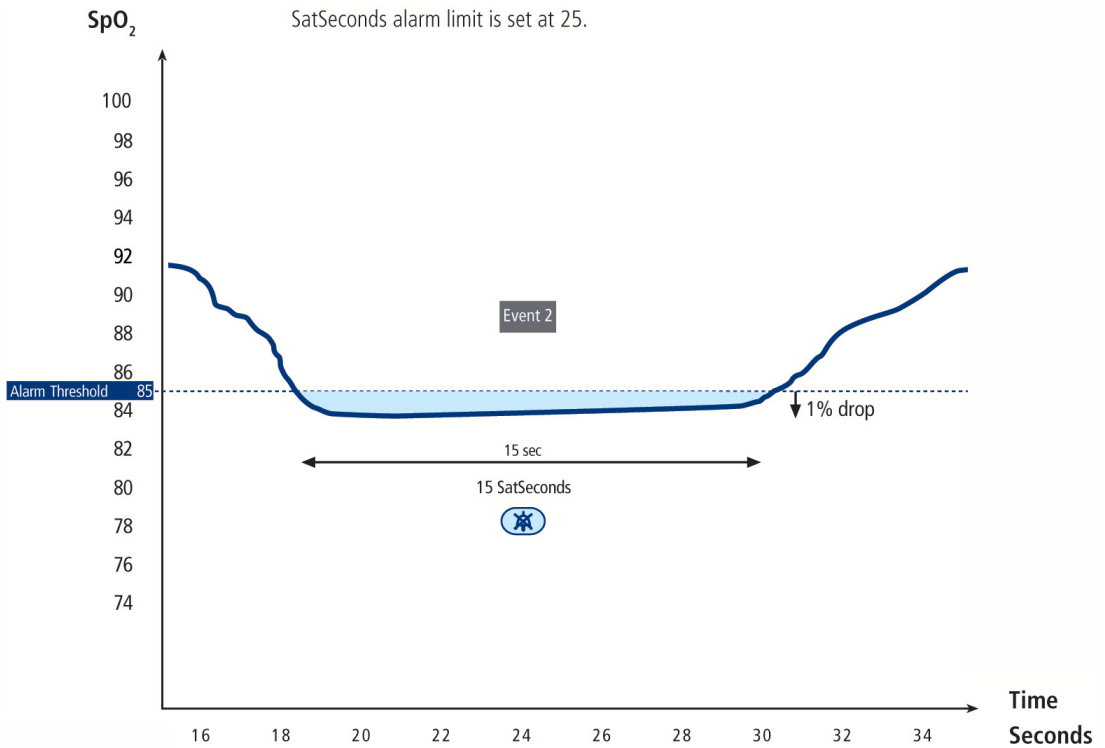

POX_10122_A

Figure 7. Third Event: Triggers SatSeconds Alarm

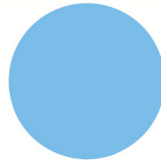

Event 3

The SatSeconds Alarm Limit is set at 25. During this event, the patient's SpO₂ drops to 75% which is 10% below the Low Alarm limit of 85%. Since the patient does not return within 2.5 seconds, there is an audible alarm.

10% drop below the Low Alarm Limit
~~X 2.5 seconds (maximum time allowed)~~
25 SatSeconds

At this level of saturation, the event would only be able to last for 2.5 seconds. However, the patient's saturation did not return within that amount of time. Therefore, an audible alarm is heard just under 3 seconds into the event.

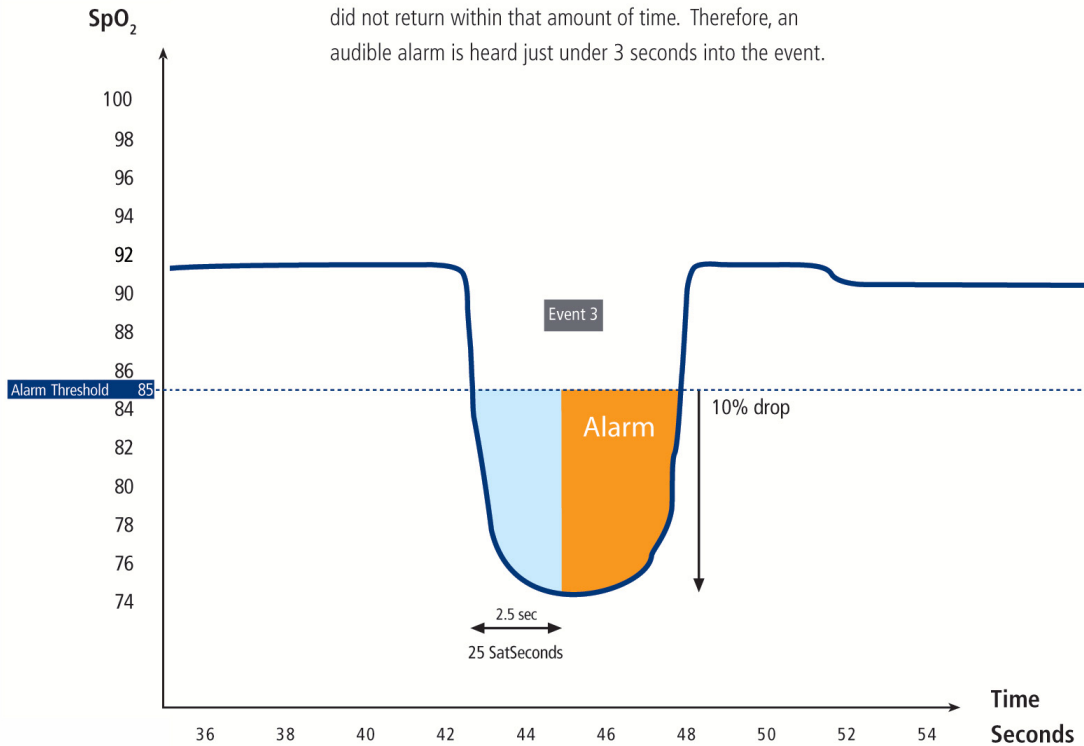

POX_10123_A

The SatSeconds “Safety Net” is for patients with saturation levels frequently below the limit, but not staying below the limit long enough for the SatSeconds time setting to be reached. When three or more limit violations occur within 60 seconds, an alarm sounds even if the SatSeconds time setting has not been reached.

Reference the *N-600x Operator's Manual* for details.

Pulse Rate Delay Alarm Management Feature

The oximeter monitors pulse rate by determining the number of pleth waves over unit time. With traditional alarm management, upper and lower alarm limits are set for monitoring pulse rate. When the pulse rate fluctuates near an alarm limit, the alarm sounds each time it violates an alarm limit. Use the Pulse Rate Delay feature to distinguish clinically significant events from minor and brief pulse rate limit violations that result in nuisance alarms. The Pulse Rate Delay feature allows a period of threshold violation before the pulse rate alarm sounds. Thus, the Pulse Rate Delay feature distinguishes clinically significant events from minor and brief pulse rate limit violations that may result in nuisance alarms.

To use the Pulse Rate Delay feature, set the traditional alarm management upper and lower pulse rate alarm limits. Then, set the Pulse Rate Delay. The Pulse Rate Delay limit controls the time the pulse rate level crosses either limit before an audible alarm sounds.

Reference *Oximeter Display View Options*, page 26, *Managing the View Display*, page 62, *Using the Pulse Rate Delay Alarm Management Feature*, page 78, and *Pulse Rate Delay Alarm Management Feature*, page 41 for details.

Oximeter Display View Options

Selecting Display Views

Select the display view for the OxiMax N-600x pulse oximeter that best suits the situation. The factory default setting is the General Care Format (GCF) display view.



Caution

Verify the movement of the blip bar, plethysmographic waveform, or flashing heart icon before accepting any oximeter data as a current measurement.

General Care Format (GCF) Display

Figure 8. General Care Format (GCF) Display View

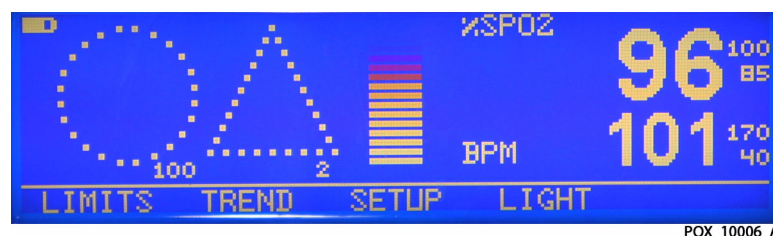

Use this display view for large, easy-to-read monitoring information. The General Care Format (GCF) display includes the pulse amplitude blip bar, current measured SpO₂ and pulse rate, and current upper and lower SpO₂ and pulse rate limits. It also includes a battery fuel gauge if running on battery power. If enabled, SatSeconds and SPD icons display. For more information, reference the *N-600x Operator's Manual*.

Plethysmographic (Pleth) Display

Figure 9. Pleth Display View

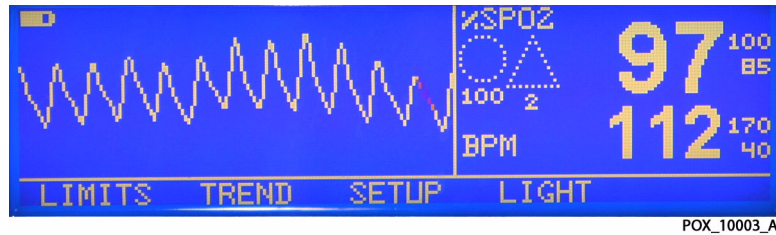

Use this display view for visual monitoring information in waveform. The plethysmographic (pleth) display includes a “wiper bar” plethysmographic waveform, menu bar, and current measured SpO₂ and pulse rate, upper and lower limit settings. It also includes a battery fuel gauge if running on battery power. Plethysmographic waveforms with peak to peak amplitudes less than ten pulse amplitude units (PAUs) are associated to one another. If enabled, SatSeconds and SPD icons display. For more information, reference the *N-600x Operator’s Manual*.

Blip Display

Figure 10. Blip Display View

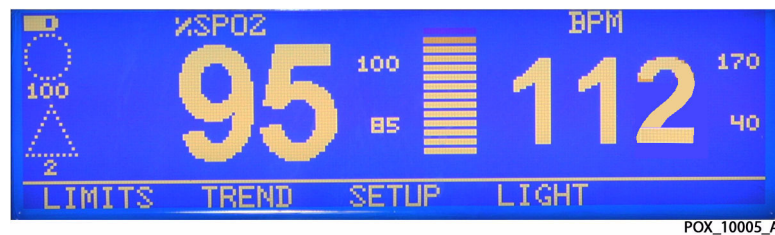

Use this display view for visual monitoring information in blip bar form. The blip display includes a pulse amplitude blip bar, current measured SpO₂ and pulse rate, current upper and lower SpO₂ and pulse rate limits. It also includes a battery fuel gauge if running on battery power. If enabled, SatSeconds and SPD icons display. For more information, reference the *N-600x Operator’s Manual*.

Real-Time Trend Display

Figure 11. Real-time Trend Display View

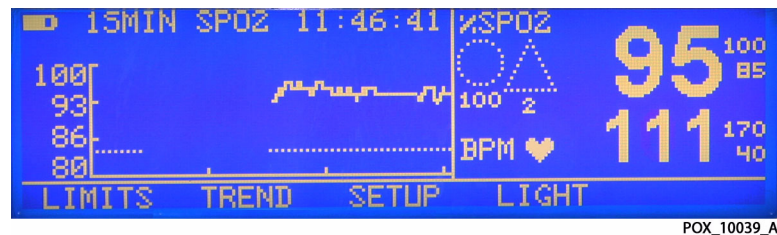

Use this display view for visual monitoring information related to real-time trends. The trend data plots are automatically updated as the oximeter calculates each new trend point, where the interval between calculations is based on the display time scale selected. The real-time trend display includes SpO₂ and/or pulse rate trend

data plots, current measured SpO₂ and pulse rates. It also includes a battery fuel gauge if running on battery power. Each time the oximeter detects a pulse, the heart icon flashes. If enabled, SatSeconds and SPD icons display. For more information, reference the *N-600x Operator's Manual*.



3 Product Specifications

Overview

This section contains OxiMax N-600x™ pulse oximeter physical and operational specifications. Ensure all product requirements are met prior to installation of the oximeter.

Physical Characteristics

Weight	5.8 lbs. (2.6 kg)
Dimensions	3.3 in. x 10.4 in. x 6.8 in. (8.4 cm x 26.4 cm x 17.3 cm)

Electrical Requirements

Power

Power Requirements	Rated at 100 to 120 volts AC (nominal 120 VAC) or 220 to 240 volts AC (nominal 230 VAC), 30 VA
Input Frequency	50/60 Hz
Fuses	Slow-blow 0.5 amp, 250 volts, IEC (5 x 20 mm) Quantity: 2 external

Battery



Note:

The battery provides approximately seven hours of battery life when new and fully-charged with no alarms, no serial data, no analog output, no nurse call output, with backlight on while using a pulse simulator set for 200 bpm, high light and low modulation.

Type	Lead acid
Voltage	6 Volts DC
Recharge	8 hours with oximeter turned off 12 hours with oximeter turned on
Shelf Life	Four months, if oximeter runs on new, fully-charged battery After four months storage, units run 33% of stated battery life
Compliance	91/157/EEC

Rating of Nurse Call Relay

Maximum Input Voltage	30 VAC or VDC (polarity is not important)
Load Current	120 mA continuous (peak 300 mA @ 100 ms)
Minimum Resistance	26.5 ohms to 50.5 ohms (40.5 ohms typical) during alarms
Ground Reference	Isolated Ground
Electrical Isolation	1500 Volts

Environmental Conditions

Operating

Temperature	5 °C to 40 °C (41 °F to 104 °F)
Altitude	-390 m to 3,012 m (-1,254 ft. to 9,882 ft.)
Atmospheric Pressure	70 kPa to 106 kPa (20.6 in. Hg to 31.3 in. Hg)
Relative Humidity	15% to 95% non-condensing

Transport and Storage

	Not in shipping container	In shipping container
Temperature	-20 °C to 60 °C (-4 °F to 140 °F)	-20 °C to 70 °C (-4 °F to 158 °F)
Altitude	-390 m to 5,574 m (-1,254 ft. to 18,288 ft.)	-390 m to 5,574 m (-1,254 ft. to 18,288 ft.)
Atmospheric Pressure	50 kPa to 106 kPa (14.7 in. Hg to 31.3 in. Hg)	50 kPa to 106 kPa (14.7 in. Hg to 31.3 in. Hg)
Relative Humidity	15% to 95% non-condensing	15% to 95% non-condensing

Performance Specifications

Measurement Range

%SpO₂ Saturation Range	1% to 100%
Pulse Rate Range	20 to 250 beats per minute (bpm)
Perfusion Range	0.03% to 20%

OxiMax™ Pulse Oximetry Sensors

Pulse Oximetry Sensor Accuracy

Table 5. Oxygen Saturation Accuracy¹

Sensor Model Type	LoSAT™ Range 60% to 80%	Standard Saturation Range 70% to 100%
MAX-A, MAX-AL	± 3.0 digits	± 2.0 digits
MAX-N ² (Adult and Neonate)	± 3.0 digits	± 2.0 digits
MAX-P, MAX-I, MAX-FAST	± 3.0 digits	± 2.0 digits
Softcare™ SC-A, -PR, -NEO ³	N/A	± 2.0 digits
MAX-R	N/A	± 3.5 digits
Low Perfusion ⁴	N/A	± 2.0 digits
Pulse Rate		
Normal Range	20 to 250 bpm	± 3.0 digits
Low Perfusion ⁴	20 to 250 bpm	± 3.0 digits

¹ Subjects used to validate measurement accuracies were healthy and recruited from the local population. Comprised of both men and women, subjects spanned a range of skin pigmentations and ranged in age from 18-50 years old. Accuracy specifications are based on controlled hypoxia studies with healthy non-smoking adult volunteers over the specified saturation range(s). Pulse oximeter readings were compared to SaO₂ values of drawn blood samples measured by hemoximetry. All accuracies are expressed as ±1 SD. Pulse oximeter equipment measurements are statistically distributed; about two-thirds of pulse oximeter measurements can be expected to fall in this accuracy (ARMS) range. Because scatter and bias of pulse oximeter and blood SaO₂ comparison commonly increase as the saturation decreases, and accuracy specifications are calculated from data spanning the stated range, different accuracy values may result when describing partially overlapping ranges.

² Clinical functionality of the MAX-N has been demonstrated on a population of hospitalized neonate patients. The observed accuracy was 2.5% in a study of 42 patients with ages of 1 to 23 days, weight from 750 to 4,100 grams, and 63 observations made spanning a range of 85% to 99% SaO₂.

³ Clinical functionality has been demonstrated in a population of hospitalized neonate patients. The observed accuracy was 3.0% in a study of 57 patients with ages of 24 to 40 weeks, weight from 710 to 5,000 grams, and 1 observations made spanning a range of 63% to 99% SaO₂.

⁴ Specification applies to N-600x oximeter performance. Reading accuracy in the presence of low perfusion (detected IR pulse modulation amplitude 0.03% - 1.5%) was validated using signals supplied by a patient simulator, and pulse rate values were varied across the monitoring range over a range of weak signal conditions and compared to the known true saturation and pulse rate of the input signals.



Note:

For a complete listing of SpO₂ accuracy across the full line of available OxiMax™ pulse oximetry sensors, contact 1.800.635.5267.

Sensor Power Dissipation

Pulse Oximetry Sensor	Dissipation
OxiMax MAX-A, -AL, -I, -N, -P, -R	52.5 mW
OxiMax Durasensor™ DS-100A	52.5 mW
OxiMax OxiCliq™ A, I, N, P	52.5 mW
OxiMax Dura-Y™ D-YS	52.5 mW
OxiMax Max-Fast™	52.5 mW
OxiMax Softcare™ SC-A, -NEO, -PR	52.5 mW

OxiMax Pulse Oximetry Sensor Operating Range

Red Light Wavelength	Approximately 660 nm
Infrared Light Wavelength	Approximately 900 nm
Optical Output Power	Less than 15 mW

Product Compliance

Product Standards for Compliance

ISO 9919:2005
EN ISO 9919: 2005

Product Safety Standards

IEC 60601-1: 1988 + A1: 1991 + A2: 1995
EN 60601-1: 1990 + A11: 1993 + A12: 1993 + A13: 1996
UL 60601-1 1st edition
CSA C22.2 No. 601.1 M90

Protection Type Class I (Internally powered)

Mode of Operation Continuous

Liquid Ingress IPX1

Degree of Safety Not suitable for use in the presence of a flammable anaesthetic gas

Electromagnetic Compatibility (EMC) Standards

IEC 60601-1-2: 2001 + A1: 2004
EN 60601-1-2: 2001 + A1: 2006

Manufacturer's Declaration

Basics



WARNING

The use of accessories, OxiMax sensors, and cables other than those specified may result in inaccurate readings of the OxiMax N-600x pulse oximeter and increased emission of the oximeter.

The OxiMax N-600x pulse oximeter is suitable for prescription use only in the specified electromagnetic environments. Use the unit in accordance with the electromagnetic environments described in this section.

Electromagnetic Compatibility (EMC)

Electromagnetic Emissions

Table 6. Electromagnetic Emissions

Emissions Test	Compliance	Electromagnetic Environment Guidance
RF emissions CISPR 11: 2004	Group 1 Class B	The oximeter is suitable for use in all establishments.
Harmonic emissions IEC 61000-3-2: 2005	Class A	The oximeter is suitable for use in all establishments.
Voltage fluctuations/ flicker emission IEC 61000-3-3: 2005	Complies	The oximeter is suitable for use in all establishments.

Electromagnetic Immunity



Note:

These guidelines may not apply in all situations. Electromagnetic propagation is affected by absorption and reflection from structures, objects, and people.

Table 7. Electromagnetic Immunity Testing

Immunity Test	IEC 60601-1-2 Test Level	Compliance Level	Electromagnetic Environment Guidance
Electrostatic discharge (ESD) IEC 61000-4-2: 2001	± 6 kV contact ± 8 kV air	± 6 kV contact ± 8 kV air	Floor should be wood, concrete, or ceramic tile. If floors are covered with synthetic material, the relative humidity should be at least 30%.
Electric fast transient/burst IEC 61000-4-4: 1995 + A1: 2000 + A2: 2001	± 2 kV for power supply lines ± 1 kV for input/output lines	± 2 kV for power supply lines ± 1 kV for input/output lines	Mains power quality should be that of a typical commercial and/or hospital environment
Surge IEC 61000-4-5: 2005	± 1 kV differential mode ± 2 kV common mode	± 1 kV differential mode ± 2 kV common mode	Mains power quality should be that of a typical commercial and/or hospital environment
Voltage dips, short interruptions and voltage variations on power supply IEC 61000-4-11: 2004	<5% UT (>95% dip in UT) for 0.5 cycle	<5% UT (>95% dip in UT) for 0.5 cycle	Mains power quality should be that of a typical commercial and/or hospital environment. If the user of the oximeter requires continued operation during power mains interruption, it is recommended that the oximeter be powered from an uninterruptible power supply or battery. Note: UT is the AC main's voltage prior to application of the test level.
	40% UT (60% dip in UT) for five cycles	40% UT (60% dip in UT) for five cycles	
	70% UT (30% dip in UT) for 25 cycles	70% UT (30% dip in UT) for 25 cycles	
	<5% UT (95% dip in UT) for five seconds	<5% UT (95% dip in UT) for five seconds	
Power frequency (50/60 Hz) magnetic field IEC 61000-4-8: 2001	3 A/m	3 A/m	If image distortion occurs, it may be necessary to position the oximeter further from the sources of power frequency magnetic fields or to install magnetic shielding. The power frequency magnetic field should be measured in the intended installation location to assure that it is sufficiently low.

Table 8. Recommended Separation Distances

Immunity Test	IEC 60601-1-2 Test Level	Compliance Level	Electromagnetic Environment Guidance
	Frequency of Transmitter		Equation for Separation Distance
Conducted RF IEC 61000-4-6: 2006	3 Vrms 150 kHz 80 MHz	3 Vrms	distance = 1.2
Radiated RF IEC 61000-4-3: 2006	3 V/m 80 MHz 800 MHz	3 V/m	distance = 1.2
	3 V/m 800 MHz 2.5 GHz	3 V/m	distance = 2.3
Rated Maximum Output Power of Transmitter in Watts	Separation Distance in Meters	Separation Distance in Meters	Separation Distance in Meters
0.01	0.12	0.12	0.23
0.10	0.38	0.38	0.73
1.00	1.20	1.20	2.30
10.00	3.80	3.80	7.30
100.00	12.00	12.00	23.00

For transmitters rated at a maximum output power not listed above, the separation distance can be estimated using the equation in the corresponding column, where P is the maximum output [power rating of the transmitter in watts (W)] according to the transmitter manufacturer.



Note:

Portable and mobile RF communications equipment should be used no closer to any part of the OxiMax N-600x pulse oximeter, including cables, than the recommended separation distance calculated from the equation appropriate for the frequency of the transmitter.

Sensor and Cable Compliance



WARNING

The use of accessories, OxiMax sensors, and cables other than those specified may result in inaccurate readings of the OxiMax N-600x pulse oximeter and increased emission of the oximeter.

Table 9. Cables and Sensors

Item	Maximum Length
Cables	
Power cord	10.0 ft. (3 m)
DOC-10 pulse oximetry cable	10.0 ft. (3 m)
Software download cable, RS-232 serial, 15 to 9 pin "D"	10.0 ft. (3 m)
Non-terminated cable, RS-232 analog, 15 pin "D"	10.0 ft. (3 m)
Printer cable, RS-232, 15 to 9 pin "D"	10.0 ft. (3 m)
Philips interface cable	3.3 ft. (1 m)
Oxinet™ III hardwire cable	10.0 ft. (3 m)
Oxinet™ III Data Cable	10.0 ft. (3 m)
Sensors	
OxiMax™ sensors: MAX-A, MAX-I, MAX-N, MAX-P, MAX-R MAX-AL	1.5 ft. (0.5 m) 3.0 ft. (0.9 m)
OxiMax Oxiband™ sensors: OXI-A/N, OXI-P/I	3.0 ft. (0.9 m)
OxiMax Durasensor™ DS-100A	3.0 ft. (0.9 m)
OxiMax OxiCliq™ sensors: P, N, I, A	OC-3 cable 3.0 ft. (0.9 m)
OxiMax Dura-Y™ sensors: D-YS, D-YSE, D-YSPD	4.0 ft. (1.2 m)

Safety Tests

Ground Integrity

100 milliohms or less

Leakage Current

The following tables display the maximum earth and enclosure leakage current allowed, as well as patient leakage.

Table 10. Earth and Enclosure Leakage Current Specifications

Earth Leakage Current					
Condition	AC Polarity	Line Cord	Neutral Line Cord	IEC 60601-1	UL 60601-1
Normal	Normal	Closed	Closed	500 μ A	300 μ A
Single Fault		Open	Closed	1000 μ A	
		Closed	Open		
Normal	Reversed	Closed	Closed	500 μ A	300 μ A
Single Fault		Open	Closed	1000 μ A	
		Closed	Open		
Enclosure Leakage Current					
Condition	AC Line Polarity	Neutral Line Cord	Power Line Ground	IEC 60601-1 UL 60601-1	
Normal	Normal	Closed	Closed	100 μ A	
Single Fault		Open	Closed	500 μ A	
		Closed	Open		
Normal	Reversed	Closed	Closed	100 μ A	
Single Fault		Open	Closed	500 μ A	
		Closed	Open		

Table 11. Patient Applied and Patient Isolation Risk Current

Patient Applied Risk Current				
Condition	AC Line Polarity	Neutral Line	Power Line Ground Cable	IEC 60601-1 UL 60601-1
Normal	Normal	Closed	Closed	100 μ A
Single Fault		Open	Closed	500 μ A
		Closed	Open	
Normal	Reversed	Closed	Closed	100 μ A
Single Fault		Open	Closed	500 μ A
		Closed	Open	
Patient Isolation Risk Current				
Condition	AC Line Polarity	Neutral Line	Power Line Ground Cable	IEC 60601-1 UL 60601-1
Single Fault	Normal	Closed	Closed	5000 μ A
	Reversed	Closed	Closed	

4 Theory of Operations

Overview

This section explains the theory behind OxiMax N-600x™ pulse oximeter operations.

Understanding Pulse Oximetry

Theoretical Principles

The OxiMax N-600x pulse oximeter uses pulse oximetry to measure functional oxygen saturation in the blood. Pulse oximetry works by applying an OxiMax™ pulse oximetry sensor to a pulsating arteriolar vascular bed, such as a finger or toe. The sensor contains a dual light source and a photo detector.

Bone, tissue, pigmentation, and venous vessels normally absorb a constant amount of light over time. The arteriolar bed normally pulsates and absorbs variable amounts of light during the pulsations. The ratio of light absorbed is translated into a measurement of functional oxygen saturation (SpO₂).

Ambient conditions, sensor application, and patient conditions can influence the ability of the oximeter to accurately measure SpO₂. Reference *Performance Considerations*, page 97.

Pulse oximetry is based on two principles: oxyhemoglobin and deoxyhemoglobin differ in their absorption of red and infrared light (measured using spectrophotometry), and the volume of arterial blood in tissue (and hence, light absorption by that blood) changes during the pulse (registered using plethysmography). A pulse oximeter determines SpO₂ by passing red and infrared light into an arteriolar bed and measuring changes in light absorption during the pulsatile cycle. Red and infrared low-voltage light-emitting diodes (LED) in the sensor serve as light sources; a photo diode serves as the photo detector.

Since oxyhemoglobin and deoxyhemoglobin differ in light absorption, the amount of red and infrared light absorbed by blood is related to hemoglobin oxygen saturation.

The oximeter uses the pulsatile nature of arterial flow to identify the oxygen saturation of arterial hemoglobin. During systole, a new pulse of arterial blood enters the vascular bed, and blood volume and light absorption increase. During diastole, blood volume and light absorption reach their lowest point. The pulse oximeter bases its SpO₂ measurements on the difference between maximum and minimum absorption (measurements at systole and diastole). By doing so, it focuses on light

absorption by pulsatile arterial blood, eliminating the effects of nonpulsatile absorbers such as tissue, bone, and venous blood.

Automatic Calibration

Because light absorption by hemoglobin is wavelength dependent and because the mean wavelength of LEDs varies, an oximeter must know the mean wavelength of the OxiMax pulse oximetry sensor's red LED to accurately measure SpO₂.

During monitoring, the oximeter's software selects coefficients that are appropriate for the wavelength of that individual sensor's red LED; these coefficients are then used to determine SpO₂.

Additionally, to compensate for differences in tissue thickness, the light intensity of the sensor's LEDs is adjusted automatically.



Note:

During certain automatic calibration functions, the OxiMax N-600x pulse oximeter may briefly display a flat line on the plethysmographic waveform. This is a normal operation and does not require any user intervention.

Functional versus Fractional Saturation

This pulse oximeter measures functional saturation where oxygenated hemoglobin is expressed as a percentage of the hemoglobin that can transport oxygen. It does not detect significant amounts of dysfunctional hemoglobin, such as carboxyhemoglobin or methemoglobin. In contrast, hemoximeters such as the IL482 report fractional saturation where oxygenated hemoglobin is expressed as a percentage of all measured hemoglobin, including measured dysfunctional hemoglobins. To compare functional saturation measurements to those from an oximeter that measures fractional saturation, fractional measurements must be converted using the listed equation.

Figure 12. Fractional Saturation Conversion Equation

$$\text{functional saturation} = \frac{\text{fractional saturation}}{100 - (\% \text{carboxyhemoglobin} + \% \text{methemoglobin})} \times 100$$

Measured versus Calculated Saturation

When calculating saturation from a blood gas partial pressure of oxygen (PO₂), the calculated value may differ from the SpO₂ measurement of a pulse oximeter. This usually occurs when saturation calculations exclude corrections for the effects of

variables such as pH, temperature, the partial pressure of carbon dioxide (PCO₂), and 2,3-DPG that shift the relationship between PO₂ and SpO₂.

Figure 13. Oxyhemoglobin Dissociation Curve

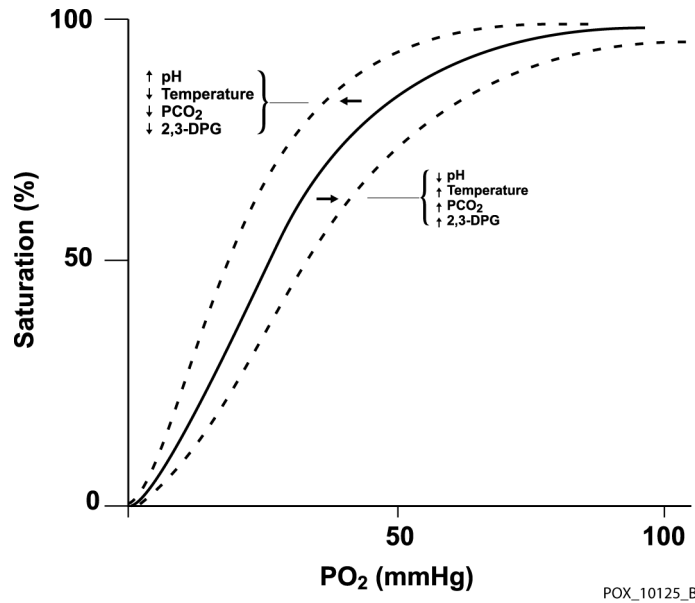

Oximeter Features

SatSeconds™ Alarm Management Feature

The oximeter monitors hemoglobin saturation with oxygen in the blood. With traditional alarm management, upper and lower alarm limits are set for monitoring SpO₂ levels. When the SpO₂ fluctuates near an alarm limit, the alarm sounds each time it violates an alarm limit. SatSeconds monitors both degree and duration of desaturation as an index of desaturation severity. Thus, the SatSeconds feature distinguishes clinically significant events from minor and brief SpO₂ limit violations that result in nuisance alarms.

Set upper and lower alarm limits using traditional alarm management methods. Then, use SatSeconds alarm management to defer the audible alarm for the specified period, even if the SpO₂ is below the selected lower alarm limit. Refer to *Using the SatSeconds™ Alarm Management Feature*, page 78, for managing SatSeconds alarms.

Pulse Rate Delay Alarm Management Feature

The oximeter also monitors pulse rate by determining the number of pleth waves over unit time. With traditional alarm management, upper and lower alarm limits are set for monitoring pulse rate. When the pulse rate fluctuates near an alarm limit, the alarm sounds each time it violates an alarm limit. The Pulse Rate Delay feature allows a period of threshold violation before the pulse rate alarm sounds. Thus, the Pulse

Rate Delay feature distinguishes clinically significant events from minor and brief pulse rate limit violations that result in nuisance alarms.

To use the Pulse Rate Delay feature, set the traditional alarm management upper and lower pulse rate alarm limits. Then, set the Pulse Rate Delay. The Pulse Rate Delay limit controls the time the pulse rate level crosses either limit before an audible alarm sounds. Refer to *Using the Pulse Rate Delay Alarm Management Feature*, page 78, for managing pulse rate alarms.

OxiMax SPD™ Alert Feature

The OxiMax SPD™ Alert (SPD) method of detecting patterns of desaturation in adults is a function of the software within the OxiMax N-600x pulse oximeter, which detects repetitive occurrences of desaturation followed by resaturation. These patterns are indicative of repetitive reductions in airflow through the upper airway and into the lungs. When SPD is enabled, the default value for SatSeconds is set to 100. Set the upper and lower SpO₂ alarm limits using traditional alarm management methods. Set the alarm type to visual only or audio and visual. The default setting of one (1) is the most sensitive to patterns of desaturation. Select from three alarm sensitivity settings: 1 (most sensitive), 2 (medium sensitivity) or 3 (least sensitive), with 1 resulting in more alarms and 3 resulting in fewer alarms, or turn it to OFF. The alarm sensitivity value appears directly under the SPD triangle icon. Refer to *Using the OxiMax SPD™ Alert Feature*, page 77, for detecting patterns of desaturation.

OxiMax™ Pulse Oximetry Sensor Technology

Use OxiMax™ pulse oximetry sensors, which are specifically designed for use with the oximeter. Identify OxiMax pulse oximetry sensors by the deep blue and/or white colors of the plugs. All OxiMax pulse oximetry sensors contain a memory chip carrying information about the sensor which the oximeter needs for correct operation, including the sensor's calibration data, model type, troubleshooting codes, and error detection data.

This unique oximetry architecture enables several new features. When an OxiMax pulse oximetry sensor is connected to the OxiMax N-600x pulse oximeter, the oximeter reads the information from the OxiMax pulse oximetry sensor memory chip, ensures it is error free, and then loads the sensor data prior to monitoring for new information. As the oximeter reads sensor information, it flashes the sensor model number on its display. This process may take a few seconds. Once the reading process is complete, the sensor model number stops flashing and monitoring begins. The sensor model number disappears after the pulse oximeter starts tracking the patient's SpO₂ and pulse rate.

Pulse oximeters containing OxiMax technology, including the OxiMax N-600x pulse oximeter, use calibration data contained in the OxiMax pulse oximetry sensor in calculating the patient's SpO₂. With sensor calibration, the accuracy of many sensors is improved, since the calibration coefficients can be tailored to each OxiMax pulse oximetry sensor. Consult the accuracy card included with the oximeter for specific

accuracy information for the oximeter with different Nellcor approved OxiMax pulse oximetry sensors.

The OxiMax N-600x pulse oximeter uses the information in the OxiMax pulse oximetry sensor, tailoring messages to better help the clinician troubleshoot client or data issues. The sensor automatically identifies its sensor type to the oximeter when attached. The oximeter determines the sensor type and recommended patient site for each model.

Functional Testers and Patient Simulators

Some models of commercially available bench top functional testers and patient simulators can be used to verify the proper functionality of OxiMax pulse oximetry sensors, cables and oximeters. See the individual testing device's operator's manual for the procedures specific to the model of tester being used.

While such devices may be useful for verifying that the pulse oximeter sensor, cabling, and oximeter are functional, they are incapable of providing the data required to properly evaluate the accuracy of a system's SpO₂ measurements. Fully evaluating the accuracy of the SpO₂ measurements requires, at a minimum, accommodating the wavelength characteristics of the sensor and reproducing the complex optical interaction of the sensor and the patient's tissue. These capabilities are beyond the scope of known bench top testers. SpO₂ measurement accuracy can only be evaluated in vivo by comparing pulse oximeter readings with SaO₂ measurements obtained from simultaneously sampled arterial blood made using a laboratory CO-oximeter.

Many functional testers and patient simulators have been designed to interface with the pulse oximeter's expected calibration curves and may be suitable for use with Nellcor oximeters and/or sensors. Not all such devices, however, are adapted for use with the Nellcor OxiMax digital calibration system. While this will not affect use of the simulator for verifying system functionality, displayed SpO₂ measurement values may differ from the setting of the test device. For a properly functioning oximeter, this difference will be reproducible over time and from oximeter to oximeter within the performance specifications of the test device.

5 Product Overview

Overview

The OxiMax N-600x™ pulse oximeter relies on unique oximetry technology and design in providing hospitals, clinicians, and caregivers accurate, timely data.

Oximeter Block Diagram

The following block diagram shows the flow of data in the OxiMax N-600x pulse oximeter, including input and output.

Figure 14. Block Diagram

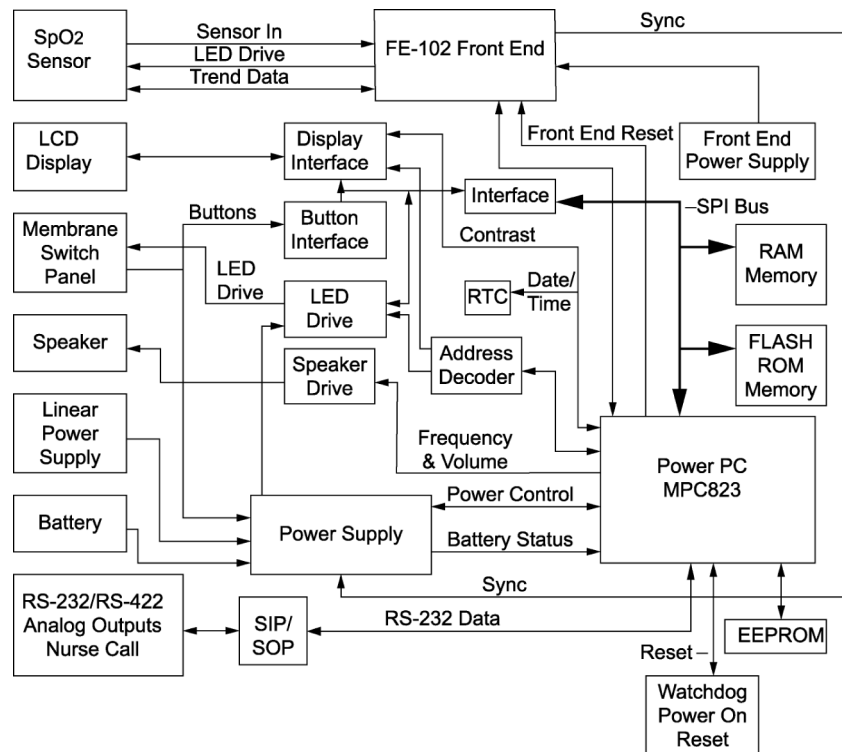

POX_10146_A

System Board Components

System Board Component Overview

The OxiMax N-600x pulse oximeter Main Board (PCB) consists of three (3) main components. These components provide support for data exchange and input from the clinician, technician, or caregiver during use.

The three primary components are listed below.

1. Secondary Input Port/Secondary Output Port (SIP/SOP)
2. NELL-1A Oximetry Module
3. User Interface (UIF)

The Secondary Input Port/Secondary Output Port and the NELL-1A Oximetry Module front end are both electrically isolated from the UIF.

Secondary Input Port/Secondary Output Port (SIP/SOP)

The Secondary Input Port/Secondary Output Port provides support for data exchange to and from the oximeter via a serial port. The SIP/SOP is electrically isolated as mandated by regulations for patient safety.

NELL-1A Oximetry Module

The OxiMax N-600x pulse oximeter contains the Motorola MPC823e PowerPC (823e) microprocessor. As shown in the block diagram above, the 823e provides the bulk of the functionality in the oximeter, acting as the “master” controller, while NELL-1A Oximetry Module handles the pulse oximetry functions and the Linear Power Supply (LPS) board microcontroller handles the AC/Battery power management tasks. Communications between the board and the Nell-1A module takes place over an asynchronous isolated bidirectional serial link. The microprocessor receives messages from the NELL-1A and extracts status, SpO₂ and pulse rates.

Communication with the LPS board takes place over a non-isolated bidirectional serial link. The microcontroller receives periodic status information that it uses for directing further activity.

High-speed SRAM and Flash ROM are provided for the 823e microprocessor on the circuit board. Low-speed SRAM is used to hold infrequently used data, primarily trend data.

The 823e retains the primary responsibility for a variety of functions.

- Processing of the oximetry data
- Display of the SpO₂ and pulse rate data, and all other display data including status LEDs on the membrane panel
- User Interface
- Serial port communication through the SIP/SOP interface
- Nurse call outputs

- Analog outputs
- Sound generation by generating the appropriate volume and frequency control settings for the speaker circuitry
- Monitoring and controlling oximeter power
- Communicating with the real-time clock (RTC) and electrically-erasable-programmable-read-only-memory (EEPROM)
- Trend data collection and storage

Static random access memory (RAM) and FLASH read-only memory (ROM) are provided for the microprocessor on the PCB. The system monitor resets the entire PCB if the +3.3 volts is out of tolerance or the watchdog timer is not periodically reset by the software.



Note:

The static RAM and the RTC for the microprocessor are powered whenever the oximeter has power, either AC power or battery power. This allows time and certain data to be maintained, even while the oximeter is turned off.

The NELL-1A is electrically isolated to reduce capacitive coupling to earth ground and improve the NELL-1A's ability to read difficult patient data.

User Interface (UIF)

The oximeter has a 240 x 64 liquid crystal display (LCD) which provides various display capabilities including numeric readouts for SpO₂ and beats per minute (BPM) pulse rate, graphical pleth wave and pulse blip bar, menu selection elements, and status/error messages. There is also a membrane panel consisting of nine (9) buttons and five (5) LED indicators. The buttons enable the user to navigate through and input menu selections using the LCD and LED interfaces. The LED indicators provide feedback to the user on various OxiMax N-600x pulse oximeter and OxiMax pulse oximetry sensor conditions. The oximeter contains primary and secondary speakers for audio output.

Power

Power is supplied to the OxiMax N-600x pulse oximeter either from an AC connection (100-120 or 200-240 VAC) or from a 6-volt, 4 ampere-hour battery. The transition between power sources is invisible to the user, from AC power to battery power or from battery power to AC power. Power can remain active during cases where AC power is lost or applied.

- The LPS microcontroller monitors the battery voltage and shuts off the unit power supply if the battery voltage becomes too low to support OxiMax N-600x pulse oximeter functionality.
- The patient isolated power supply for the OxiMax N-600x pulse oximeter is an isolated switcher which generates +3.3, +5, and +12 volts.

Pulse Oximetry Sensors and Cables

Before attaching any of the various Nellcor approved OxiMax pulse oximetry sensors to the oximeter, refer to the individual OxiMax Sensor's *Directions for Use* (DFU) and the *OxiMax Sensor Accuracy Grid* (SAG). Also reference the *Product Specifications* chapter for *Pulse Oximetry Sensor Accuracy*, page 31.

The NELL-1A oximetry module drives the sensor's LEDs, conditions the incoming signal, and provides adjustable gain status. The oximetry module measures the sensor's analog outputs and continually controls the gain stages and LED drive current to ensure the signals are within the measurement range.

6 Setting Up the Oximeter

Safety Reminders



WARNING

To ensure patient safety, do not place the pulse oximeter in any position where it might tip or fall on the patient.



WARNING

As with all medical equipment, carefully route patient cabling to reduce the possibility of patient entanglement or strangulation.



WARNING

Ensure that the speaker is clear of any obstruction. Failure to do so could result in an inaudible alarm tone.



WARNING

Disconnect the oximeter and Nellcor OxiMax pulse oximetry sensor from the patient during magnetic resonance imaging (MRI) scanning. Objects containing metal can become dangerous projectiles when subjected to the strong magnetic fields created by MRI equipment. Also, induced currents could potentially cause burns.



WARNING

To ensure accurate performance and prevent device failure, do not subject the OxiMax N-600x pulse oximeter to extreme moisture, such as direct exposure to rain. Such exposure may cause inaccurate performance or device failure.



WARNING

Do not use any OxiMax N-600x pulse oximeter, OxiMax pulse oximetry sensor, cables, or connectors that appear damaged.



WARNING

Do not lift the pulse oximeter by the pulse oximetry cable or power cord. The cable or cord may disconnect, potentially dropping the pulse oximeter on a patient or a damaging surface.



WARNING

The OxiMax N-600x pulse oximeter is not defibrillator-proof. It may remain attached to the patient during defibrillation or during use of an electrosurgical unit, however readings may be inaccurate during the defibrillation and shortly thereafter.



WARNING

In the USA, do not connect the pulse oximeter to an electrical outlet controlled by a wall switch, since this increases the risk of removal of AC power to the pulse oximeter.



WARNING

Use only Nellcor-approved OxiMax pulse oximetry sensors and pulse oximetry cables when connecting to the OxiMax sensor connector. Connecting any other cable or sensor influences accuracy of sensor data, which may lead to adverse results.



WARNING

Use only the Nellcor DOC-10 pulse oximetry cable with the OxiMax N-600x pulse oximeter. Use of another pulse oximetry cable will have an adverse effect on performance. Do not attach any cable that is intended for computer use to the OxiMax N-600x pulse oximeter sensor port.



WARNING

The OxiMax N-600x pulse oximeter should not be used adjacent to or stacked with other equipment. If adjacent or stacked use is necessary, observe the oximeter to verify normal operation in the desired configuration.



Note:

The OxiMax N-600x™ pulse oximeter incorporates watchdog timers which reset the oximeter in the event of software errors.

Connecting to an AC Power Source



WARNING

In the USA, do not connect the pulse oximeter to an electrical outlet controlled by a wall switch, since this increases the risk of removal of AC power to the pulse oximeter.



Caution

Set the Supply Voltage Selector switch to the correct voltage (115V or 230V) to avoid equipment damage and ensure proper battery charge.



Caution

Ensure the pulse oximeter is properly grounded when operating on AC power. If you are uncertain whether the AC outlet is properly grounded, disconnect the pulse oximeter from the outlet and use battery power. Contact a qualified electrician to examine the outlet for ground connections.



Caution

Use only the Nellcor hospital-grade power cord.

To connect to an AC power source

1. Set the Supply Voltage Selector switch to the applicable voltage.

Figure 15. Back Panel Supply Voltage Selector and Power Connector

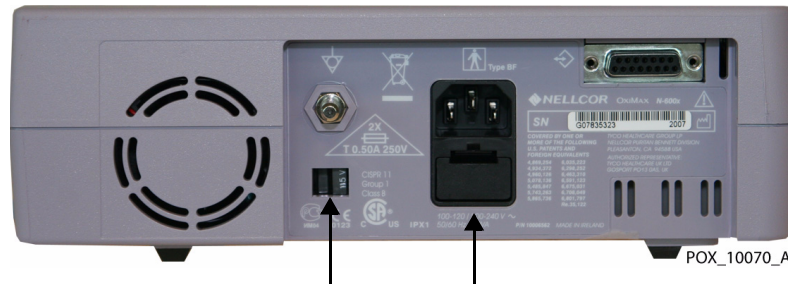

2. Plug the female connector end of the power cord into the power connector on the rear of the oximeter.
3. Plug the male connector of the power cord into a properly grounded AC outlet.
4. Verify the oximeter's AC power indicator is lit.

**Note:**

If the AC power indicator is not lit, check the power cord, supply voltage selector switch, user-accessible fuses, and AC power outlet.

Using Battery Power

Overview

**WARNING**

Do not tighten battery terminal clips unless AC power is disconnected.

**WARNING**

If the oximeter is operating on an AC power source with a fully-depleted battery and the AC power is subsequently lost, the oximeter will shut down immediately.

**Caution**

If the battery has been in storage for longer than six months, or if the battery does not fully recharge, the battery should be replaced. After the battery has been replaced and a new battery had been charged, an "EEE 575 Trends Lost" message appears when the oximeter is turned on. Turn the oximeter off and wait three seconds. Then turn the oximeter on again. After the extended power-on self-test, the oximeter runs on AC or battery power.

**Caution**

To fully recharge a low or fully-depleted battery, connect the oximeter to an AC power outlet. It may take up to eight hours if the oximeter is turned off or 12 hours if the oximeter is turned on.

**Caution**

The battery terminal clips may loosen after repeated insertions. After replacing the battery, with the AC power still disconnected, check the battery terminal clips for secure fit and tighten if necessary using needle nose pliers.

**Caution**

Repeated deep discharge reduces the life of the battery.

Power is supplied to the OxiMax N-600x pulse oximeter either from an AC connection (100-120 or 200-240 VAC) or from a 6-volt, 4 ampere-hour battery. The oximeter internal battery can be used to power the oximeter during transport or when AC power is not available. The transition between power sources is invisible to the user, from AC power to battery power or from battery power to AC power. A new, fully charged battery provides approximately seven hours of monitoring time under certain conditions.

- Pulse simulator set for 200 bpm, high light and low modulation
- No audible alarms sound
- No analog or serial output devices are attached to the oximeter, including serial data, analog output, and nurse call output
- Default display brightness setting

To fully charge the battery



Caution

To fully recharge a low or fully-depleted battery, connect the oximeter to an AC power outlet. Charge the battery for at least eight hours with the oximeter turned off or twelve hours with the oximeter turned on. Replace the battery if fewer than four bars are lit after fully charging the battery. Recharge the battery at least every three months, allowing the full charge time if it is the first recharge in several weeks.

1. Connect the oximeter to an AC power source. The oximeter will not power up without connection to AC power.
2. Verify the oximeter is off and the AC Power/Battery Charging indicator is lit. On AC power up, the battery fuel gauge shows empty. The oximeter operates on AC power while the battery is charging. When the oximeter is fully charged, all four bars are lit on the indicator.
3. Until the battery is recharged, the message, "UNIT WILL SHUT DOWN IF AC POWER IS LOST" appears. Press the ALARM SILENCE key twice to remove the message from the screen before the oximeter can be used for patient monitoring. The oximeter is now operational.



Caution

Should a low battery alarm sound, connect the oximeter to an AC power source and then clear the alarm by pressing the ALARM SILENCE key. If the oximeter is operated on an AC power source with a depleted battery and AC power is subsequently lost, the oximeter will shut down immediately.

When all of the following conditions are present for 15 minutes, the N-600x pulse oximeter automatically shuts down.

- The oximeter is running on battery power.
- No keys have been pressed.
- No pulse has been detected. If a patient is not connected to the OxiMax pulse oximetry sensor or the sensor is disconnected from the oximeter, the oximeter cannot detect data.
- No alarms are present, other than low battery or a non-correctable error.

**Note:**

Whenever the oximeter is connected to AC power source, the battery is being charged. Nellcor recommends the oximeter remain connected to an AC power source when not in use. This ensures full battery power when the oximeter is needed.

Connecting an OxiMax™ Pulse Oximetry Sensor

**WARNING**

Use only Nellcor-approved OxiMax pulse oximetry sensors and pulse oximetry cables when connecting to the OxiMax sensor connector. Connecting any other cable or sensor influences accuracy of sensor data, which may lead to adverse results.

The bottom of the oximeter screen displays the OxiMax pulse oximetry sensor type when connecting an OxiMax pulse oximetry sensor to the oximeter or when the oximeter completes POST with an OxiMax pulse oximetry sensor attached.

**Note:**

Physiological conditions, medical procedures, or external agents that may interfere with the oximeter's ability to detect and display measurements include dysfunctional hemoglobin, arterial dyes, low perfusion, dark pigment, and externally applied coloring agents, such as nail polish, dye, or pigmented cream.

**Note:**

Sensor LED light emissions fall within Class 1 level, according to IEC 60825-1:2001.

1. Firmly connect a DOC-10 pulse oximetry cable to the oximeter's SpO₂ Sensor Port.

Figure 16. SpO₂ Sensor Port Connector



2. Open the plastic latch at the other end of the DOC-10 pulse oximetry cable.

Figure 17. Insertion of Cable into Plastic Latch on DOC-10 Pulse Oximetry Cable

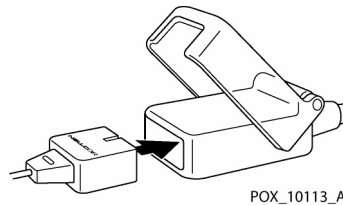

3. Plug the cable and a Nellcor OxiMax SpO₂ sensor together.
4. Snap the plastic latch down over the connectors.

5. Apply the sensor to the patient. Be sure to read the *Directions for Use* accompanying the sensor.
6. When the oximeter detects a valid pulse, it enters the monitoring mode and displays real-time patient data.

Reducing EMI (Electromagnetic Interference)



Caution

This device has been tested and found to comply with the limits for medical devices related to IEC 60601-1: 1988 + A1: 1991 + A2: 1995, EN60601-1:1990 + A11: 1993 + A12: 1993 + A13: 1996, and the Medical Device Directive 93/42/EEC. These limits are designed to provide reasonable protection against harmful interference in a typical medical installation.

Because of the proliferation of radio frequency transmitting equipment and other sources of electrical noise in health care environments (for example, electrosurgical units, cellular phones, mobile two-way radios, electrical appliances, and high-definition television), it is possible that high levels of such interference due to close proximity or strength of a source may result in disruption of N-600x pulse oximeter performance.

The OxiMax N-600x pulse oximeter is designed for use in environments in which the pulse can be obscured by electromagnetic interference. During such interference, measurements may seem inappropriate or the oximeter may not seem to operate correctly. Disruption may be evidenced by erratic readings, cessation of operation, or other incorrect functioning. If this occurs, survey the site of use to determine the source of this disruption, and take the listed actions to eliminate the source.

1. Turn equipment in the vicinity off and on to isolate the offending equipment.
2. Reorient or relocate the interfering equipment.
3. Increase the separation between the interfering equipment and the oximeter.

The oximeter generates, uses, and can radiate radio frequency energy and, if not installed and used in accordance with these instructions, may cause harmful interference with other susceptible devices in the vicinity.

7 Operating the Oximeter

Overview



WARNING

Dispose of internal battery in accordance with local requirements and regulations.

This section identifies methods for viewing and collecting patient oxygen saturation data using the OxiMax N-600x™ pulse oximeter. It describes menu navigation, power on/off and display options, parameter ranges, OxiMax™ pulse oximetry sensor attachments, and configuring default settings suitable for the specific care environment.

Schedule regular maintenance and safety checks with a qualified service technician every 24 months. In the case of mechanical or functional damage, contact Nellcor's Technical Services Department at 1.800.635.5267 or your local Nellcor representative.

Monitoring Oximeter Power

Battery Fuel Gauge

Any time the oximeter is not connected to an AC power source, the oximeter runs on an internal battery. A battery fuel gauge indicator displays the remaining battery power. For more information, reference *Connecting to an AC Power Source*, page 50 and *Using Battery Power*, page 51.



Caution

If the battery is fully depleted, and the AC power is lost, the oximeter will shut down.

Table 12. Battery Fuel Gauge Levels





Level	Description
	Indicates 89-100% (approx. 6-7 hours) battery capacity remains.
	Indicates 64-88% (approx. 4.5-6 hours) battery capacity remains.
	Indicates 39-63% (approx. 2.5-4.5 hours) battery capacity remains.

Table 12. Battery Fuel Gauge Levels

Level	Description
	Indicates 14-38% (approx. 1-2.5 hours) battery capacity remains.
	Indicates 1-13% (less than 1 hour) battery capacity remains.



Note:

The levels in Table 12 are based on a new battery. As a battery is used and recharged over time, it may provide only 75% capacity of a new battery. For example, a battery that is two years old may provide only 75% (3 bars) of the capacity of a new battery.

Low Battery Indicator



Caution

Have a qualified service technician replace the internal battery every 24 months. The lead acid battery is recyclable. Do not dispose of the battery by placing it in the regular trash. Dispose of the battery in accordance with local guidelines or contact Nellcor’s Technical Services department to arrange for disposal.



Caution

The pulse oximeter default settings return to factory default settings with a fully discharged or replaced battery. Have a qualified service technician reset the oximeter to match the institutional defaults, following the instructions in the *N-600x Service Manual*.



Note:

If the AC voltage selector switch on the oximeter rear panel does not match your AC voltage source, the oximeter may run on battery power, even though it is connected to an AC power source, which eventually results in a low priority alarm and a lighted low battery indicator. Ensure that the switch setting matches your AC voltage.



The Low Battery Indicator lights and a low priority alarm begins to sound when approximately 15 minutes of monitoring time remain on the existing battery charge.

Refer to Table 12 for a description of the low and critical battery conditions. When the battery capacity reaches a critically low battery condition, the Low Battery indicator flashes and a high priority alarm sounds for about ten seconds before the oximeter shuts off.

Cancel a low battery audible alarm by pressing the ALARM SILENCE key. The low battery indicator and display screen message continue to display. Silence the audible alarm by connecting the oximeter to an AC power source. The low battery indicator remains lit as long as the battery is in a low voltage condition.

If the oximeter backlight is turned off during a low battery condition, the backlight cannot be turned back on until connected to an AC power source.



Note:

As the battery is used and recharged over time, the amount of time between the onset of the low battery alarm and the oximeter shut-off may become shorter.

Powering the Oximeter

Power Prerequisites



Caution

If any indicator or display element does not light when the pulse oximeter is turned on, do not use the oximeter. Instead, contact qualified service personnel, your local Nellcor representative, or Nellcor's Technical Services Department.



Caution

During POST (immediately after power-up), confirm that all indicators light, all display segments turn on, and the pulse oximeter speaker sounds a sequence of three ascending tones. After the POST process completes, verify that a single one-second tone sounds.

Before using the oximeter in a clinical setting, verify the oximeter is safe and working properly. Verify proper working condition at each power up by following the procedure below.

Power-On Self-Test (POST)

At power on, the OxiMax N-600x pulse oximeter performs a power-on self-test (POST), which tests the oximeter circuitry and functions, then proceeds to the default display. With a sensor cable and an OxiMax pulse oximetry sensor attached, the unit is ready to register and record patient trend data.

Power-up performance tests verify both power-on self-test (POST) and power-on defaults and alarm range limits. For defaults and alarm range, see *Adjusting the Factory Default Settings*, page 72.



Note:

Physiological conditions, medical procedures, or external agents such as dysfunctional hemoglobin, arterial dyes, low perfusion, dark pigment, and externally applied coloring agents such as nail polish, dye, or pigmented cream may interfere with the oximeter ability to detect and display measurements.

To power up the oximeter



WARNING

If you do not hear the power-on self-test (POST) pass tone, do not use the oximeter. Instead, contact Nellcor's Technical Services or your local Nellcor representative.



WARNING

Ensure the speaker is clear of any obstructions. Failure to do so could result in an inaudible alarm tone.



Note:

In addition to serving as the POST pass verification, the POST pass tone also functions as an audible confirmation that the speaker is performing properly. If the speaker does not function, the alarm warning sounds cannot be heard.



Note:

For standard usage, connect sensor cables prior to turning on the oximeter. Do NOT connect any sensor cables to the oximeter when verifying oximeter functionality as part of performance testing.

1. Connect the oximeter to an AC power source. The oximeter can run on battery power, but for performance testing, use an AC power source.
-  2. Verify the oximeter is off and the AC Power Indicator is lit.
3. Turn on the oximeter by pressing the ON/STANDBY key.
4. Ensure all of the front panel indicators illuminate for about two seconds.
 - a. Within ten seconds, all LEDs, pixels and the backlight should illuminate.
 - b. The indicators should remain lit for two seconds.
 - c. The LCD display should show the NELLCOR logo and the firmware version of the OxiMax N-600x pulse oximeter.
5. Observe the LCD screen for the POST splash screen, which displays for approximately five seconds.
6. Listen for three ascending tones, then a one-second beep, indicating proper operation of the speaker and successful completion of the power-on self-tests.

Figure 18. POST Splash Screen



Note:

The firmware version shown above is only a sample. Check the oximeter for the currently installed firmware version and record it prior to contacting technical assistance. Always have it available when contacting Nellcor's Technical Services Department or a local Nellcor representative for technical assistance.

7. Ensure all indicators turn off except the AC Power/Battery Charging indicator and the LCD screen.

The oximeter begins normal operation.

If the oximeter detects an internal problem during the POST process, an error tone sounds and the oximeter displays an error code (EEE) and the corresponding number. See *Troubleshooting*, page 137.

Figure 19. Error Condition Screen, Battery Failure



Note:

For standard usage, connect sensor cables prior to turning on the oximeter. Do not connect any sensor cables to the oximeter when verifying oximeter functionality as part of performance testing.



Note:

Physiological conditions, medical procedures, or external agents that may interfere with the monitor's ability to detect and display measurements, include dysfunctional hemoglobin, arterial dyes, low perfusion, dark pigment, and externally applied coloring agents such as nail polish, dye, or pigmented cream.

Automatic Shutdown and Power Off

Automatic Shutdown

When all of the following conditions are present for 15 minutes, the OxiMax N-600x pulse oximeter automatically shuts down.

- The oximeter is running on battery power.
- No buttons have been pressed.
- No pulse is detected (for example, when a patient is not connected to the OxiMax pulse oximetry sensor or the pulse oximetry sensor is disconnected from the oximeter).
- No alarms are present (other than low battery or a non-correctable error).

Power Off



To turn off the oximeter, hold the power softkey until the display darkens and it powers off.

Using OxiMax™ Pulse Oximetry Sensors

For more information on selecting the right pulse oximetry sensor for the specific patient and situation, see the *N-600x Operator's Manual*. Consider all possible variables. If still in doubt, contact Nellcor's Technical Services Department at 1.800.635.5267 or your local Nellcor representative.

Sensor Detection



WARNING

Do not use any other cables to extend the length of the DOC-10 pulse oximetry cable. Increasing the length of the DOC-10 cable will degrade signal quality and may lead to inaccurate measurements.



WARNING

Use only the Nellcor DOC-10 pulse oximetry cable with the OxiMax N-600x pulse oximeter. Use of another pulse oximetry cable will have an adverse effect on performance. Do not attach any cable that is intended for computer use to the SpO₂ sensor port.



WARNING

Use only Nellcor-approved OxiMax pulse oximetry sensors and pulse oximetry cables when connecting to the sensor connector. Connecting any other cable or sensor influences accuracy of sensor data, which may lead to adverse results.

When an OxiMax pulse oximetry sensor is connected to the oximeter, a “SENSOR TYPE: xxxx” message displays for between four and six seconds at the bottom of the oximeter display. The message identifies the type (model) of pulse oximetry sensor connected to the oximeter. The type is used to determine the action messages in the sensor message(s) function. For a pulse oximetry sensor containing data, the message identifies the sensor data type. For a blank pulse oximetry sensor, the message identifies the oximeter’s current setting used to write data to the sensor. The settings are SpO₂ and SpO₂+BPM.

Figure 20. Sensor Type Message Display

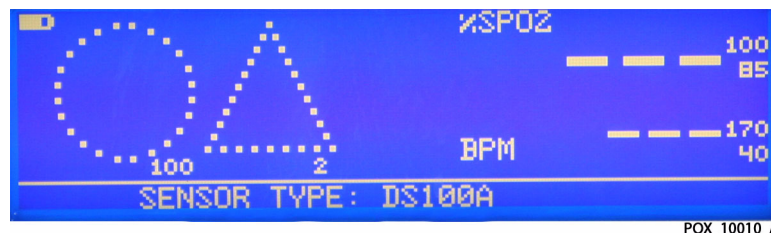

Note:

The type of data recorded is only displayed when data are present in the OxiMax pulse oximetry sensor.

The oximeter displays zeros in the %SpO₂ and Pulse Rate displays while searching for a valid pulse. For optimal performance, allow the oximeter to search and lock onto a pulse for approximately five to ten seconds.

When a valid pulse is detected, the oximeter enters monitoring mode and displays patient parameters using one of the available displays: general care format (factory default display view), waveform, blip bar, or real-time trend view. The SatSeconds icon appears in each display screen when enabled. If the SPD feature is enabled, both the SatSeconds and SPD icons appear in each display. See *Oximeter Display View Options*, page 26.

The movement of the blip bar, the plethysmographic waveform, or the flashing heart icon indicates real-time data display. The pulse beep tone is an audible indicator of the real-time patient data.



Caution

If the pulse beep tone does not sound with each pulse, the pulse beep volume is set to zero, the speaker is malfunctioning, or the signal is corrupt.

When first applying an OxiMax pulse oximetry sensor to a patient, the oximeter may lose a pulse signal. If a pulse signal is lost, an alarm sounds and a poor signal condition message displays on the oximeter screen. At this point, the oximeter displays [--- / ---](three dashes over three dashes) and remains in the Pulse Search mode for five seconds before displaying the poor signal condition screen. The poor signal condition screen is part of the Sensor Messages feature.

Figure 21. Poor Signal Condition Message



Sensor Detection Failure

Upon successful completion of the POST process, the oximeter sounds a one-second tone indicating that the oximeter has passed POST.

Should the oximeter fail to detect an OxiMax pulse oximetry sensor, the oximeter displays dashes [- - -] and the Pulse Search indicator does not light.

Managing the Oximeter Backlight

Adjust the brightness, contrast, and backlight of the oximeter screen to suit each individual situation.

To turn off the oximeter backlight

1. Press the LIGHT softkey.
2. Then press OFF.



Note:

Any of the following conditions turn on the backlight:

- Pressing any of the softkeys
- Pressing and holding the HELP/CONTRAST key
- Pressing the ALARM SILENCE key
- Any alarm

To adjust the backlight brightness

1. With the oximeter in the normal monitoring mode, press the LIGHT softkey.

2. Press the ADJUST UP or ADJUST DOWN key below the ALARM SILENCE key on the oximeter panel until the desired backlight brightness is obtained.

To adjust the oximeter screen contrast

1. With the oximeter in the normal monitoring mode, press and hold the HELP/CONTRAST softkey while pressing the ADJUST UP or ADJUST DOWN key below the ALARM SILENCE key on the oximeter panel until obtaining the desired contrast.
2. Press the HELP/CONTRAST key to return to the normal monitoring mode.

Managing the View Display

Select the preferred method of viewing real-time data. Reference *Oximeter Display View Options*, page 26, for details. Selections will last until power-cycling the oximeter or manually selecting another view.

Adjusting the Volume of Audible Tones

Adjusting the Pulse Beep Volume

The pulse beep emits its tone with each real-time event, based on data received from the sensor.

To adjust the pulse beep volume

1. With the oximeter in the normal monitoring mode, press and hold the ADJUST UP key below the ALARM SILENCE key on the oximeter panel to increase the pulse beep volume.
2. With the oximeter in the normal monitoring mode, press and hold the ADJUST DOWN key to decrease the pulse beep volume.

Managing Oximeter Alarms

Alarms occur when the oximeter detects a condition that requires user intervention or attention. The Alarm Volume allows for volume adjustment of alarm tones.

To set the alarm volume

1. With the oximeter in the normal monitoring mode, press the ALARM SILENCE key until the alarm volume level displays and sounds on the oximeter.

Figure 22. Alarm Volume Control Screen



POX_10015_A

2. While continuing to press the ALARM SILENCE key, press and hold the ADJUST UP or ADJUST DOWN key to increase or decrease the volume.

**Note:**

Default alarm volume is seven (7). Select the appropriate value for the situation. The alarm volume adjusts up to ten (10) and down to one (1).

Managing Audible Alarms

To set the alarm silence duration

The Alarm Silence Duration display enables you to adjust the alarm silence duration.

1. With the oximeter in the normal monitoring mode, press the ALARM SILENCE key until the alarm silence duration setting displays. The alarm silence durations available are 30-, 60-, 90-, and 120-second intervals.

Figure 23. Alarm Silence Duration Screen



2. Press and hold the ALARM SILENCE key and the ADJUST UP key below the ALARM SILENCE key on the oximeter panel to increase the alarm silence duration setting.
3. Press and hold the ALARM SILENCE key and the ADJUST DOWN key to decrease the alarm silence duration setting.

**Note:**

Releasing the ADJUST UP or ADJUST DOWN key sets the alarm silence duration.

**Note:**

Default alarm silence duration is 60 seconds. Select the appropriate value for the situation. The alarm silence duration adjusts up to 120 seconds and down to 30 seconds.

To disable audible alarms

**WARNING**

Do not disable the audible alarm function or decrease the audible alarm volume if the patient's safety could be compromised.

**WARNING**

Pressing ALARM SILENCE will keep ALL alarms from sounding for the alarm silence duration period.

**Note:**

The ability to set the alarm silence duration to OFF can be enabled or disabled by qualified service personnel.

1. With the oximeter in the normal monitoring mode, press the ALARM SILENCE key until the alarm silence duration setting displays.
2. While pressing the ALARM SILENCE key, press and hold the ADJUST UP key until OFF displays. Release both keys.



Note:

Once audible alarms are disabled, the orange LED above the ALARM SILENCE key lights to indicate the disabled alarm state.

To select the standby mode

Normally, use the standby mode setting for the patient who must temporarily leave the oximeter.

The standby mode enables the oximeter to retain alarm limit settings in effect when a caregiver temporarily removes a patient’s sensor.

1. Verify the oximeter alarm limits are configured to the monitored patient.
2. Disconnect the sensor from the oximeter.
3. Press the ALARM SILENCE key to silence the audible alarms.
4. Press the ALARM SILENCE key to disable the alarm messages.

Figure 24. Standby Mode



The oximeter is now in the standby mode. Reconnect the sensor to the oximeter and the patient to return to normal monitoring.

Using Oximeter Softkey Menus

Navigating Menu Options

Hierarchy

The oximeter’s softkey menu hierarchy allows the user or technician to configure and operate the oximeter, select options, and view trend or event data.



Note:

The oximeter compiles trend data on each entry or re-entry to the Trend menu. To refresh active trend data, re-enter the Trend menu from the Main menu.

Sensor sub-menu choices differ, depending on what type of patient alarm event data are stored in the sensor chip.

Common Menu Options

1. **BACK softkey**—Return to the previous menu level without exiting the selected menu area entirely.
2. **NEXT softkey**—Proceed to the next screen of menu options for that menu set.
3. **EXIT softkey**—Exit to the main menu or press BACK until you reach an EXIT menu option.

Main Menu

The main menu softkey options provide access to several submenus.

Figure 25. Main Menu Options

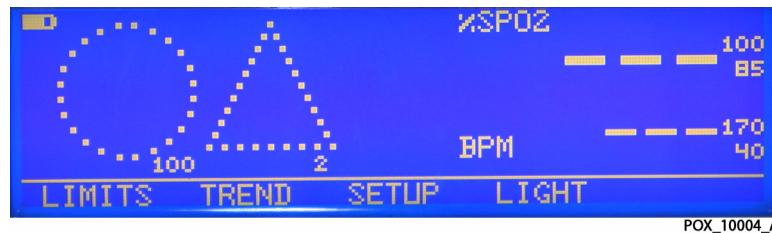

1. **LIMITS Menu**—Select standard oximeter upper and lower SpO₂ or pulse rate limits and alarm management settings for either adults or neonates.
2. **TREND Menu**—Select method of viewing oximeter trend and sensor data.



Note:

In the case of a SatSeconds or an SPD event, the oximeter proceeds straight to the MONITR menu. Clear any alarm condition(s) to access the TREND menu.

3. **SETUP Menu**—Use this softkey to control oximeter viewing options, sensor setup, clock setup and language viewing options. Also configure the communication port, the nurse call feature, and control analog voltage.
4. **LIGHT Menu**—Leave the display backlight on, adjust brightness, or choose to turn the display backlight off.

LIMITS Menu

Figure 26. Limit Menu Options for Neonates



1. **SELECT softkey**—Use this softkey only after you have chosen the NEO screen or the ADULT screen using the appropriate softkey. Then, use the SELECT softkey to scroll through each limit setting option until you reach the limit value you wish to change.

2. **NEO softkey**—Use this softkey to set upper and lower limits for neonates. Scroll through each limit setting option using the SELECT softkey until you reach the limit value you wish to change. Change the value by pressing the ADJUST UP or ADJUST DOWN key below the ALARM SILENCE key on the oximeter panel until you reach the desired value. This setting only holds until power recycle. Decimal points to the right of the displayed values indicate those limits have been modified from the power-on default values. See *Adjusting the Factory Default Settings* on page 72.
 - a. **Upper and Lower SpO2 Limits**—The neonate default upper limit is 95% and lower limit is 85%. An alarm sounds each time patient saturation violates these alarm limits.
 - b. **SatSeconds Alarm Management**—The neonate default SatSeconds value is OFF. For more information, refer to *Using the SatSeconds™ Alarm Management Feature*, page 78.
 - c. **OxiMax SPD™ Alert (SPD) Feature**—This option is not available for neonates. For more information, refer to *Using the OxiMax SPD™ Alert Feature*, page 77.
 - d. **Upper and Lower Pulse Rate Limits**—The neonate default upper limit is 190 bpm and lower limit is 90 bpm. An alarm sounds each time patient pulse rate violates these alarm limits.
 - e. **Pulse Rate Delay Alarm Management**—The neonate default Pulse Rate Delay is OFF, but can be set to a five (5) or ten (10) second pulse rate alarm delay. For more information, refer to *Using the Pulse Rate Delay Alarm Management Feature*, page 78.
3. **ADULT softkey**—Use this softkey to set upper and lower limits for adult and pediatric patients. Scroll through each limit setting option using the SELECT softkey until you reach the limit value you wish to change. Change the value by pressing the ADJUST UP or ADJUST DOWN key below the ALARM SILENCE key on the oximeter panel until you reach the desired value. This setting only holds until power recycle. Decimal points to the right of the displayed values indicate those limits have been modified from the power-on default values. See *Adjusting the Factory Default Settings* on page 72.
 - a. **Upper and Lower SpO2 Limits**—The adult default upper limit is 100% and lower limit is 85%. An alarm sounds each time patient saturation violates these alarm limits.
 - b. **SatSeconds Alarm Management**—The adult default SatSeconds value is 100 SatSeconds. For more information, refer to *Using the SatSeconds™ Alarm Management Feature*, page 78.
 - c. **OxiMax SPD™ Alert (SPD) Feature**—The SPD feature is not indicated for use on pediatric patients, but on adult patients only. The adult default SPD alarm sensitivity is a value of one (1) for most sensitive to patterns of desaturation. For more information, refer to *Using the OxiMax SPD™ Alert Feature*, page 77. When SPD is enabled, the SatSeconds feature is automatically enabled with a setting of 100.
 - d. **Upper and Lower Pulse Rate Limits**—The adult default upper limit is 170 bpm and lower limit is 40 bpm. An alarm sounds each time patient pulse rate violates these alarm limits.
 - e. **Pulse Rate Delay Alarm Management**—The adult default Pulse Rate Delay is OFF, but can be set to a five (5) or ten (10) second pulse rate alarm delay. For more information, refer to *Using the Pulse Rate Delay Alarm Management Feature*, page 78.

TREND Menu

Choose the type of trend data to view by selecting trend data from the oximeter (MONITR) or trend data from the pulse oximetry sensor (SENSOR) in the Trend menu.

1. **MONITR Menu**—Isolate oxygenation (SpO₂) or pulse (PULSE) trend data or view them both together (DUAL) for a specified length of time. Establish trend data parameters for specific time segments and set minimum and maximum trend values.
 - a. **VIEW Menu**—Isolate oxygenation (SpO₂) or pulse (PULSE) trend data or view them both together (DUAL). Access the HIST and Amplitude submenus by selecting the NEXT Option.
 - **DUAL softkey**—View oxygenation (SpO₂) and pulse (BPM) trend data together for a specified length of time.
 - **SpO₂ softkey**—Isolate oxygenation (SpO₂) trend data for a specified length of time.
 - **PULSE softkey**—Isolate pulse (PULSE) trend data for a specified length of time.
 - **HIST softkey**—Choose to delete or keep current trend data history. To delete, select YES. To keep, select NO and return to the HIST menu, go BACK, or EXIT to the Main Menu.
 - **AMP softkey**—Set the trend data view to “Pulse Amplitude Units” (PAU) using the AMP (amplitude) Menu. This is an arbitrary unit of measure gauging the distance from the peak to the valley of a pulse waveform. The trend data when set to PAU can register amplitudes up to 200 PAU.
 - b. **ZOOM Menu**—Access to the TIME option, SCALE option, AUTO option, and BACK option if the trend view is set in DUAL, SpO₂, or PULSE mode.



Note:

The ZOOM menu will not allow access to the options listed if it is in AMP mode. SCALE and AUTO options do not appear as options without trend data history to review.

- **TIME softkey**—Select from hours to minutes to seconds for viewing a specific time segment of trend data. Cycle through the options by pressing the TIME softkey. The options proceed in the following order: 48h, 36h, 24h, 12h, 8h, 4h, 2h, 1h, 30m, 15m, 40s, or 20s.
- **SCALE softkey**—Select the maximum and minimum values for the SAT or PULSE trend graph. Default SAT trend values are 10 to 100. Default PULSE trend values are 5 to 250. Cycle through the options by pressing the Select softkey. The options proceed in the following order: ±5, ±10, ±15, ±20, ±25, ±30, ±35, ±40 and ±50 units variance.
- **AUTO softkey**—Obtain the maximum and minimum rounded values based on all graphed trend data.
- **DELETE softkey**—Choose to delete or keep current trend data. To delete, select YES. To keep, select NO and return to the previous menu.

2. **SENSOR Submenu**—The SENSOR menu is only available when using a single-patient OxiMax pulse oximetry sensor. After connecting an OxiMax pulse oximetry sensor, the bottom indicator on the left will blink for 60 seconds.
 - a. **GRAPH softkey**—Display events in reverse chronological order from top to bottom of the display. View previous or next graphs if available. Return to the SENSOR Menu using the BACK softkey.
 - b. **TABLE softkey**—Display events in graph form. Show previous or next tables if available. PRINT table data or go BACK to the SENSOR Menu.

SETUP Menu

Use the SETUP menu to choose the preferred display screen, set temporary limits and sensitivity, set oximeter time and date, select the preferred language, or select the communication protocol, nurse call features, and response mode from the setup menu. With a pulse oximetry sensor that retains the trend data, access the sensor trend history data.

1. **VIEW Menu**—Select plethysmographic waveform, blip display, trend data display or general care format (GCF) display view. Returns to default display after power cycle.
 - a. **PLETH softkey**—Access plethysmographic (pleth) waveform display.
 - b. **BLIP softkey**—Access blip bar display.
 - c. **TREND Menu**—Access trend data display. Similar to MONITR trend view menu option.
 - **VIEW softkey**—Display sensor trend data. Isolate oxygenation (SpO2 Option) or pulse (PULSE Option) trend data or viewing them both together (DUAL Option).
 - **ZOOM softkey**—Access to the TIME Option, SCALE Option, AUTO Option, and BACK Option if the trend view is set in DUAL, SpO2, or PULSE mode.
 - d. **GCF softkey**—Access the default general care format (GCF) display, which includes the blip bar as well as SpO2, pulse rate readings and limits, as well as SatSeconds and SPD icons in a large, easy-to-view format.
2. **SENSOR Menu**—Access the sensor trend history menu. This menu is only available if you have a pulse oximetry sensor type that retains the trend data in a chip on the pulse oximetry sensor.
 - a. **DATA softkey**—Access the sensor trend history data. The unit identifies which type of pulse oximetry sensor it is, as well as type of available data.
 - b. **MSG softkey**—Determine if messaging is enabled or disabled (Yes or No) and review sensor events (Yes or No).
3. **CLOCK Menu**—Access to set the clock, both date and time.



WARNING

The pulse oximetry sensor extrapolates from the date and time provided by the Nellcor OxiMax N-600x pulse oximeter when recording the sensor event record to the sensor. The accuracy of the date/time is determined by the date/time setting of the pulse oximeter. Set the pulse oximeter date and time to the correct value before connecting

a record-enabled sensor to keep the date and time consistent for as long as the sensor remains connected. Since a sensor with sensor event record data can be transported from one oximeter to another, having discrepancies in the date/time between oximeters and the sensor event record data will affect the order in which the sensor event record data appear. To eliminate this potential problem, set all oximeters within an institution to the same time.

To set the date and time

1. With the oximeter in the normal monitoring mode, press the SETUP softkey.
2. Press the NEXT softkey.
3. Press the CLOCK softkey.
4. Press the SET softkey.
5. Press the SELECT softkey to select the TIME and DATE fields as shown.

TIME HOURS : MINUTES : SECONDS

DATE DAY - MONTH - YEAR

Figure 27. Time and Date Screen



POX_10020_A

6. Use the ADJUST UP or ADJUST DOWN keys below the ALARM SILENCE key to change the selected value.
 7. Press the EXIT softkey.
4. **LANG Menu**—Select and view one of eleven (11) languages for ease in reading oximeter screens, as well as obtaining and printing client data in the preferred language. Available languages are listed below.
- ENGLISH
 - DANSK (Danish)
 - DEUTSCH (German)
 - ESPAÑOL (Spanish)
 - FRANCAIS (French)
 - ITALIANO (Italian)
 - NEDERLANDS (Dutch)
 - NORSK (Norwegian)
 - PORTUG (Portuguese)
 - SUOMI (Finnish)
 - SVERIGE (Swedish)

To change the displayed language setting

1. With the oximeter in the normal monitoring mode, press the SETUP softkey.
2. Press the NEXT softkey.
3. Press the LANG softkey.

Figure 28. Displayed Language Selection Screen



4. Use the ADJUST UP or ADJUST DOWN keys below the ALARM SILENCE key on the oximeter panel to select the desired language.
5. Press the EXIT softkey.



Note:

The selected language displays until the oximeter is turned OFF. Any changes in language selection do not last beyond power-off, but return to default English, unless qualified service personnel set the selected language as a default by following the procedures outlined in *Service Function Menus*, page 130.

1. **COMM Menu**—From the SETUP menu, press the NEXT softkey. Use the SELECT softkey to toggle between the baud rate and communication protocol. Arrow up or down to select the proper baud rate. Baud rates include 19200, 9600, and 2400 baud for all protocols except SPDout, which allows 115200, 57600, and 19200 baud. Arrow up or down to select the proper communication protocol. The OxiMax N-600x pulse oximeter provides a bedside monitor communication for interfacing with the protocols listed below. The factory default protocol is ASCII.

Table 13. Communication Protocol Options

Communication Protocols	N-600x using up to Firmware 2.0 Default Baud Rate	N-600x with Firmware 2.0 and above Default Baud Rate
ASCII	9600	9600
CLINICAL	19200	19200
GRAPH (Graphics)	9600	N/A
OXINET	9600	N/A
PHILIPS	19200	19200 Use only 19200
SPACELBS (Spacelabs)	9600	N/A
MARQ (GE Marquette)	9600	N/A
DATEX (Datex-Ohmeda)	2400	N/A
SPDout	N/A	Default 115200 Available: 19200, 57600, 115200

2. **NCALL Menu**—From the SETUP menu, press the NEXT softkey twice so the NCALL (Nurse Call) menu option is available. Set voltage from +5 VDC to +12 VDC using Norm + or set voltage from -5 VDC to -12 VDC using Norm- when there is no audible alarm. Voltages switch polarity when the audible alarm sounds. Return to the COMM/NCALL menu using the Back softkey. Exit to the Main Menu by pressing EXIT.
3. **ANALOG Menu**—From the setup menu, press the NEXT softkey three times to reach the Analog menu option. Select 0 Volt, 1 Volt, or Step options to calibrate analog signals. Return to the Analog/MODE menu using the Back Option. Exit to the Main Menu by pressing EXIT.
4. **MODE softkey**—The response mode establishes the frequency the oximeter uses to calculate, record, and display SpO2 saturation levels, but does not affect the calculation of pulse rate. The response mode, however, may impact the SPD alarm behavior. From the SETUP menu, press the NEXT softkey twice to reach the MODE menu option.
 - a. **Normal Mode**—Default response mode responds to changes in blood oxygen saturation in five- to seven-seconds when calculating %SpO2. When in Normal Mode, the screen does not display the Fast Mode icon.
 - b. **Fast Response Mode**—Fast mode responds to changes in blood oxygen saturation levels in two- to four-seconds when calculating %SpO2. This can be particularly helpful for situations that require close monitoring. The Fast Mode icon in italics appears in the lower right corner of the screen when in Fast Mode.

≡ SPO2



Note:

The response mode display screen includes the current SpO2 response mode setting and the current measured SpO2 and pulse rate. If SatSeconds is enabled, the SatSeconds indicator displays. If SPD is enabled, both SatSeconds and SPD icons will display.

To set the response mode

1. With the oximeter in the normal monitoring mode, press the SETUP softkey.
2. Press the NEXT softkey three times.
3. Press the MODE softkey.

Figure 29. %SpO2 Response Mode Selection Screen



POX_10025_A



Note:

When the oximeter is in the FAST response mode, the oximeter may produce more SpO2 and pulse rate alarms than expected. The response mode, however, may impact the SPD alarm behavior.

4. Use the ADJUST UP or ADJUST DOWN keys below the ALARM SILENCE key on the oximeter panel to select the desired response mode.
5. Press the EXIT softkey.

LIGHT Menu

1. **OFF softkey**—Use the OFF softkey to turn the backlight off entirely. This option does not remain after power cycle, but returns to the factory default brightness. Use the ADJUST UP or ADJUST DOWN keys below the ALARM SILENCE key on the oximeter panel to brighten or dim the display backlight.
2. **EXIT softkey**—Exit to the Main Menu.

Adjusting the Factory Default Settings

Overview



WARNING

Audible alarms should not be silenced if patient safety could be compromised.



WARNING

Each time the pulse oximeter is used, check alarm limits to ensure that they are appropriate for the patient being monitored.



WARNING

The SPD feature is for use with adults patients only. In Neonate Mode, the SPD feature remains OFF.



Caution

Use of the SPD alarm feature does not change the need to set threshold limits appropriate to the patient being monitored.

The OxiMax N-600x pulse oximeter is shipped with factory default settings. Factory default settings are divided into two groups: adult and neonate. The oximeter lists adult-pediatric alarm limit settings rather than neonate settings at power-up. Set the oximeter’s operating mode to adult-pediatric or neonatal using the LIMITS softkey. This setting remains active until the oximeter is turned OFF. As a qualified service technician, set institutional default settings, if they are different than the power-on default settings, using *Service Function Menus*, page 130.

Use the softkeys to change alarm limits, displays, baud rates, time and date, and trend data views. Some values cannot be saved as power-on default values.

- The oximeter will not accept an %SpO2 Lower Alarm Limit of less than “85” as a power-on default.
- The oximeter will not accept an AUDIBLE ALARM OFF option as a power-on default.

An attempt to save either of these values as default results in an invalid tone. These limits can be adjusted lower for the current patient, but return to power-on defaults at power-off.



Note:

The SPD feature automatically sets the SatSeconds value to 100.

Changing Adult and Neonate Default Settings

Table 14. Adult and Neonate Default Settings

Option	Adult Default Settings	Neonate Default Settings
%SpO2 Lower Alarm Limit	85%	
%SpO2 Upper Alarm Limit	100%	95%
Alarm Silence Duration	60 Seconds	
Alarm Silence Duration OFF Setting	Disabled	
Alarm Silence Reminder	Enabled	
Alarm Volume	7 of 10	
Display Contrast	Midrange	
Display Format	GCF	
Backlight Brightness	8 (Battery Power) 10 (AC Power)	
Language	English	
Pulse Beep Volume	4 of 10	
Pulse Rate Lower Alarm Limit	40 BPM	90 BPM
Pulse Rate Upper Alarm Limit	170 BPM	190 BPM
Pulse Rate Delay	Off	
Allow Pulse Rate Delay	Yes	
Response Mode	Normal	
Sensor Adjust Enable	Yes	
SatSeconds	SPD enabled 100 SPD disabled Off	Off
Allow SatSeconds	Yes	
SPD	SPD enabled 1	Always Off (Disabled)
Allow SPD	Yes	No
Real-Time Trend Display	%SpO2	
Real-Time Trend Scale	15 Minutes	
Trend Scale	8 Hours	
Nurse Call Polarity	Normally Low	
Data Port Baud Rate	9600	
Data Port Protocol	ASCII	

To set adult or neonatal modes



WARNING

Supplemental oxygen will attenuate patterns of desaturation. A patient's respiratory compromise can be proportionally more severe before patterns appear in the saturation trend. Remain vigilant when monitoring a patient on supplemental oxygen.



WARNING

The SPD feature is for use with adults patients only. In Neonate Mode, the SPD feature remains OFF.

1. With the oximeter in the normal monitoring mode, press the LIMITS softkey. The oximeter displays the ADULT LIMITS or NEONATE LIMITS screen, based on institutional or default settings.
 - a. The adult limits screen displays the institutional or factory default settings appropriate to adult and pediatric patients.

Figure 30. Setting Adult and Pediatric Limits Screen



POX_10019_A

- b. The neonate limits screen displays the institutional or factory default settings appropriate to neonatal patients.

Figure 31. Setting Neonate Limits Screen



POX_10021_A

2. Press the NEO or ADULT softkey to set the desired ADULT LIMITS or NEONATE LIMITS.

Setting Temporary Limits

The initial values in the limits screen are the factory default settings listed in *Adult and Neonate Default Settings*, page 74, or the institutional default settings set by qualified service personnel. A decimal point (.) immediately follows any modified

value for a particular patient in the limits screen. These values return to the factory or institutional default values after power cycle.

Figure 32. Setting Adult Limits Screen



POX_10019_A

To set limits

To adjust the upper and lower saturation and pulse rate limits, select the Adult or Neonate Limit display. The Limit display includes the alarm limit table and current measured %SpO2 and pulse rates. The title of the alarm limit table indicates whether the oximeter is in Adult or Neonate monitoring mode. If SatSeconds or SPD are enabled, the Limit display also includes the SatSeconds and SPD icons.



Note:

Limit changes remain in effect as long as the oximeter power continues, but return to the institutional default limits when oximeter power is turned off. Only qualified service personnel may change factory defaults to institutional defaults by following the procedures outlined in *Service Function Menus*, page 130.

1. Press the LIMITS softkey.
 - a. When Adult Limits are selected, the following current limits display.

Figure 33. Adult and Pediatric Limits Screen



POX_10019_A

- b. When Neonate Limits are selected, the following current limits display.

Figure 34. Neonate Limits Screen



POX_10021_A

2. Press the ADULT or NEO softkey to select the Adult-Pediatric or Neonatal Limits screen.
3. Press the SELECT softkey to select the parameter to be adjusted.
4. Use the ADJUST UP or ADJUST DOWN keys below the ALARM SILENCE key on the oximeter panel to increase or decrease the selected limit parameter.

5. Repeat steps as necessary to complete the alarm limits setup.
6. Wait for the display to time-out to accept the changes or press the EXIT softkey to close the display and return to the normal monitoring mode.

Using the OxiMax SPD™ Alert Feature

To set the OxiMax SPD™ Alert (SPD) sensitivity



WARNING

Supplemental oxygen will attenuate patterns of desaturation. A patient's respiratory compromise can be proportionally more severe before patterns appear in the saturation trend. Remain vigilant when monitoring a patient on supplemental oxygen.



WARNING

The SPD feature is for use with adults patients only. In Neonate Mode, the SPD feature remains OFF.

The SPD sensitivity setting establishes a threshold for how sensitive the oximeter is to patterns of desaturation. The default setting of one (1) is the most sensitive.



Note:

When SPD is enabled, the SatSeconds feature is automatically enabled with a setting of 100.



Note:

The ability to adjust the alarm limit default settings can be enabled or disabled by qualified service personnel as described in *Service Function Menus*, page 130.



Note:

Prior to changing SPD sensitivity settings, clear all alarms.

1. With the oximeter in the normal monitoring mode, press the LIMITS softkey. The current alarm limits display.
2. Press the SELECT softkey until highlighting the SPD sensitivity setting. The default setting of one (1) is the most sensitive to patterns of desaturation, but may also lead to more alarms.

Figure 35. SPD Sensitivity Setting



POX_10024_A

3. Use the ADJUST UP key to select a setting that is less sensitive to desaturation patterns, that also results in fewer alarms. The setting of three (3) is the least sensitive to patterns of desaturation.
4. Press the EXIT softkey to save your selection.

Using the Pulse Rate Delay Alarm Management Feature

To set the alarm delay

1. With the oximeter in the normal monitoring mode, press the LIMITS softkey.
2. Press SELECT softkey until highlighting the alarm delay setting, highlighting the default setting of OFF.
3. Use the ADJUST UP key to select a five (5) second alarm delay or a ten (10) second alarm delay.
4. Press the EXIT softkey to save your selection.

Figure 36. Pulse Rate Delay Setting

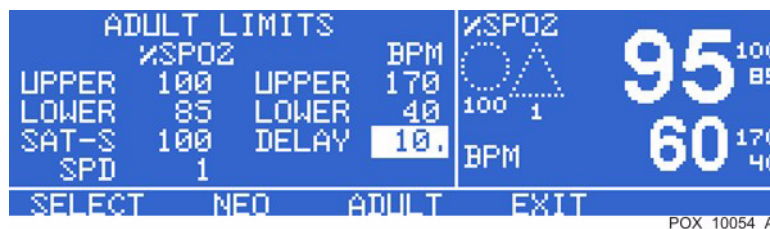

Using the SatSeconds™ Alarm Management Feature

To set SatSeconds alarm limit

To adjust the SatSeconds limit, select the adult or neonate alarm limit display.



Note:

The ability to adjust the SatSeconds Alarm limit default settings can be enabled or disabled by qualified service personnel as described in *Service Function Menus*, page 130.

1. With the oximeter in the normal monitoring mode, press the LIMITS softkey. The current alarm limits display.
2. Press the SELECT softkey twice to select %SpO₂ SAT-S.

Figure 37. Setting the SatSeconds Alarm Limit

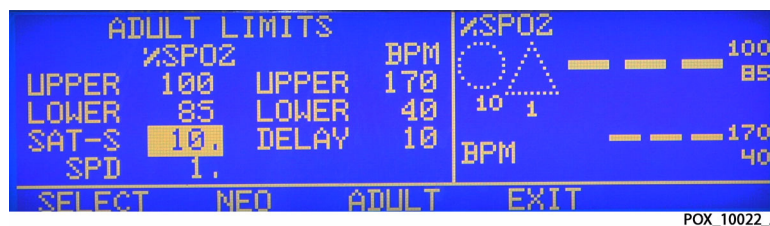

3. Use the ADJUST UP or ADJUST DOWN keys below the ALARM SILENCE key on the oximeter panel to select the limit. The choices are 10, 25, 50, 100 SatSeconds or OFF. A decimal to the lower right indicates it is not a default setting.
4. Press the EXIT softkey to save your selection.

8 Managing the Data Port

Managing Oximeter Trend Data

Reference the *N-600x Operator's Manual* for more information about displaying and reading patient trend data.

Data Port Connectivity

Overview

Use the data port on the back of the OxiMax N-600x™ pulse oximeter to output patient data by connecting the oximeter to a PC or serial printer.

When connecting the oximeter to a printer or PC, verify proper operation prior to clinical use. Both the oximeter and the printer or PC must be connected to a grounded AC power outlet. The oximeter protocol setting must be ASCII.

Any printer or PC connected to the oximeter's data port must be certified according to IEC Standard 60950-1: 2nd edition. All combinations of equipment must be in compliance with IEC Standard 60601-1-1:2000 Requirements for Medical Electrical Systems. Anyone who connects a printer or PC to the data output port configures a medical system and is therefore responsible for ensuring the system complies with Requirements for Medical Electrical Systems IEC Standard 60601-1-1:2000 and the electromagnetic compatibility IEC Standard 60601-1-2: 2001 + A1: 2004.

Data Port Requirements

Connect the data port to a serial printer or PC by using a cable terminated with the following devices.

- An AMP connector (AMP part number 747538-1)
- A ferrule (AMP part number 1-747579-2)
- Compatible pins (AMP part number 66570-2)

The cable should not exceed 25 feet (7.6 meters) in length using RS-232 protocol or 4,000 feet (1219.2 meters) in length using RS-422 protocol. The external ITE (Information Technology Equipment) device must be certified to UL Standard 60950-1:2007 or IEC Standard 60950-1: 2nd edition. The cable used must have a braided shield that provides 100% coverage, such as a Belden cable (Belden part number 9609 or 9616) or equivalent. The shield must have a 360-degree connection to the metal shell on the DB-15 connector and to the connector on the PC or serial printer.



Caution

Do not create sharp bends in the cable, as this may tear or break the shielding.
No hardware flow control is used. However, support exists for XON/XOFF flow control in ASCII mode.

Data Port Pinouts



WARNING

If the serial port, analog outputs, or nurse call lines are shorted, remote communication may be lost.

- **RS-232 Format**—Pins 2, 3, and 5 provide RS-232 format data. When building an RS-232 cable, do not add a resistor and keep cable length to a maximum of 25 feet.
- **RS-422 Format**—Pins 1, 4, 9, and 12 provide RS-422 format data. When building an RS-422 cable, add a resistor (120 ohms, 1/2 watt, 5%) between pin 1 and pin 9 of the cable and keep cable length to a maximum of 4,000 feet. Plug the end of the cable with the resistor added into the oximeter.
- **Differential Data Transmission**—Pins 3 and 4 (TxD+ and TxD-) are the differential transmit data pair.
- **Differential Data Reception**—Pins 1 and 2 (RxD+ and RxD-) are the differential receive data pair.

Table 15. Data Port Signal Pinouts

Pin Number	Signal Name
1	RxD+ (RS-422 [+] input)
2	RxD_232 (RS-232 input)
3	TxD_ (RS-232 output)
4	TxD+ (RS-422 [+] output)
5	Signal Ground (isolated from Earth Ground)
6	AN_ (analog saturation output)
7	NC_NO (relay closure nurse call, normally open)
8	NC_NC (relay closure nurse call, normally closed)
9	RxD- (RS_422 [-] input)
10	Signal Ground (isolated from Earth Ground)
11	Nurse Call (RS-232-level-output)
12	TxD- (RS-422 [-] output)
13	AN_PULSE (analog pulse rate output)
14	AN_PLETH (analog pleth waveform output)
15	NC_COM (relay closure nurse call, common lead)

Figure 38 illustrates the pin layouts as viewed from the rear panel. The conductive shell connects to earth ground when connected to a PC or printer.

Figure 38. Data Port Pin Layout

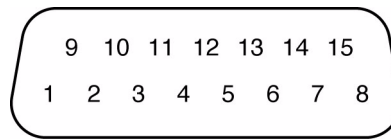

POX_10063_A



Note:

When the oximeter is turned off, the contact at pin 7 is closed and pin 8 is open.

Data Port Communications

Send data from the oximeter to a computer by using a data cable with a Null modem connector or cross-type cable installed between the oximeter and the computer. Select the ASCII comm protocol (see *Communication Protocol*, page 84). Data sent to the computer is serial, eight (8) data bits, no parity, one (1) stop bit XON/XOFF flow control and is space-delineated. After making the connection, real-time data flows to the computer. Every two seconds, the oximeter sends a new line of data. See *Real-Time Output*, page 88.

Holding the Ctrl-key on the computer keyboard and pressing “C” twice accesses an interactive mode. Activating the interactive mode halts the real-time serial output, while accepting serial input. The oximeter displays five options on the computer screen while accepting serial input.

These options provide the caregiver or technician the opportunity to request printouts and to adjust the oximeter date and time.

1. **Dump Instrument Info**—Prints or displays single line of oximeter data, including the oximeter software version, CRC number, and total operating time. Information useful to Nellcor’s personnel.
2. **Set Date and Time**—When the oximeter ships from the factory, the date and time are set to the local factory time zone. If battery removal or disconnection occurs, the time clock will not reflect the actual date and time. After restoring battery power, use this feature to change the date and time via the computer. The format for date and time is DD-MM-YY HH:MM:SS. Move the cursor under the value to be changed and enter the new value.

3. **Dump Trend**—Obtain current trend information. View up to 45 hours of trend information. Information presented includes:

- Printout Type
- Oximeter Type
- Software Revision and CRC data
- %SpO2 and Pulse Rate Limit Settings
- Adult or Neonate Setting
- Response Mode
- Date And Time
- %SpO2
- Pulse Rate
- Pulse Amplitude
- Status

Figure 39. Sample Trend Dump

N600x VERSION 2.0.4.0		CRC:0000		SpO2 Limit: 85-100% PR Limit: 40-170BPM	
ADULT 100SAT-S		SPO2 RESP MODE: NORMAL			
TIME	%SPO2	BPM	PA	Status	
27-OCT-08 13:41:57	90	60	5		
27-OCT-08 13:41:59	90	60	5		
27-OCT-08 13:42:01	90	60	5		
Output Complete					

POX_10077_A

4. **Dump Error Log**—Intended for Nellcor’s personnel to obtain or view information from memory that includes instrument type, software revision level, printout type, time of printout, operating time of the recorded error, error number, task number, address, and count.

5. **Exit Interactive Mode**—Closes the interactive mode and returns the data port to normal operation.

To establish data port communication

1. Use the Data Port Setup display to set the baud rate and the protocol of the data port on the OxiMax N-600x pulse oximeter.
2. With the oximeter in the normal monitoring mode, press the SETUP softkey.
3. Press the NEXT softkey twice and then press the COMM softkey.
4. Press the SELECT softkey.

Figure 40. Serial Port Setup Screen, Baud RateProtocol Selection

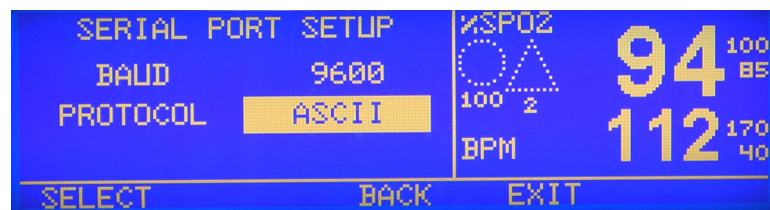

POX_10035_A

- Press the ADJUST UP or ADJUST DOWN softkeys to select the desired protocol. Protocol options for the OxiMax N-600x pulse oximeter differ from those of the oximeter with the SPD feature activated. The factory default protocol is ASCII. See *Communication Protocol Compatibility and Output*, page 83.

Table 16. Communication Protocol Compatibility and Output

Communication Protocols	N-600x with Firmware up to 2.0 Default Baud Rate	N-600x with Firmware 2.0 and Above	
		Default Baud Rate	Output includes SPD data fields
ASCII	9600	9600	Yes ¹
CLINICAL	19200	19200	Yes
GRAPH (Graphics)	9600	N/A	N/A
OXINET	9600	N/A	N/A
PHILIPS	19200	19200 Use only 19200	No
SPACELBS (Spacelabs)	9600	9600	N/A
MARQ (GE Marquette)	9600	N/A	N/A
DATEX (Datex-Ohmeda)	2400	N/A	N/A
SPDout	N/A	Default 115200 Available: 19200, 57600, 115200	Yes

¹ Not provided in real-time output

- Press the SELECT softkey.



Note:

When SPD is enabled, the Clinical and SPDout protocols include SPD information. Results cannot be predicted for host systems without upgrades to support the extra SPD information. See Table 16: *Communication Protocol Compatibility and Output*, on page 83.

- Press the ADJUST UP or ADJUST DOWN softkeys below the ALARM SILENCE key on the oximeter panel to select the desired baud rate, should it differ from the default for that particular protocol.
- Press the EXIT softkey.

Accessing Data Using the Comm Port and a Computer

Capture the data displayed on the computer screen and use as a text file or in a spreadsheet.

To access data using a computer:

- Open a terminal program, such as Hyper Terminal.

2. Verify the communications format is compatible with the data port of the oximeter. If the communications format is compatible, real-time data begins to be displayed on the computer.
3. Capture the text to a file.
4. Press Ctrl-C to halt the data flow.
5. Import the data file into the spreadsheet. The data can now be manipulated by the commands of the spreadsheet. Some formatting of the data may be necessary.

Configuring the Data Port Interface

Obtain printouts or patient data by connecting an appropriate RS-232 cable to the data port on the back of the OxiMax N-600x pulse oximeter and communicating with a Nellcor Oxinet™ III monitoring system or personal computer. The data port also provides analog signals representing SpO₂, pulse rate, and pulse amplitude, as well as providing a remote nurse call function.

The OxiMax N-600x pulse oximeter provides a bedside oximeter communication for interfacing with Philips monitors.

Adjust data port options using the appropriate softkey menu items.

Communication Protocol

Overview



WARNING

Do not silence or decrease the volume of the OxiMax N-600x pulse oximeter audible alarm if patient safety could be compromised.



Note:

Setting the communication protocol automatically sets the communication baud rate.

Change the baud rate to match the abilities of any attached equipment. Perform the following procedure to change the baud rate.

To adjust the communication baud rate:

1. Turn on the oximeter by pressing the ON/STANDBY button.
2. Press the SETUP softkey.
3. Press the NEXT softkey twice.
4. Press the COMM softkey.
5. Use the ADJUST UP and ADJUST DOWN buttons to select the desired baud rate.
6. Press the EXIT softkey to set the baud rate. The baud rate setting will be in effect until the oximeter is powered off.

**Note:**

To save the baud rate setup for the oximeter as institutional default settings, See *Adjusting the Factory Default Settings*, page 72. Use care when performing this procedure, since all settings will be saved as institutional default settings.

To use the communication protocol:

Use the COMM softkey to select the appropriate communication protocol supported for use with the data port.

- ASCII used for printouts and Oxinet III output
- CLINICAL intended for Nellcor use only
- PHILIPS interfaces the OxiMax N-600x pulse oximeter with a Philips monitor
- SPDout used for faster communication baud rates

**Note:**

Setting the communication protocol automatically sets the communication baud rate.

To change the communication protocol:

1. Turn on the oximeter by pressing the ON/STANDBY button.
2. Press the SETUP softkey.
3. Press the NEXT softkey twice.
4. Press the COMM softkey.
5. Press the SELECT softkey.
6. Use the ADJUST UP and ADJUST DOWN buttons to select the desired protocol.
7. Press the EXIT softkey set the protocol. The protocol setting is in effect until the oximeter is powered off.

**Note:**

To save the protocol setup for the oximeter as an institutional default setting, see *Adjusting the Factory Default Settings*, page 72. Use care when performing this procedure, since all settings will be saved as institutional default settings.

Philips Communications**WARNING**

Do not silence or decrease the volume of the OxiMax N-600x pulse oximeter audible alarm if patient safety could be compromised.

**Caution**

Alarms still originate from the OxiMax N-600x pulse oximeter.

The OxiMax N-600x pulse oximeter sends SpO₂, pulse rate, and alarm status data to the Philips monitor. The Philips monitor requires a Philips VueLink™ Aux Plus B interface module (A05 option) to interface with the OxiMax N-600x pulse oximeter.

The RS-232 hardware interface cable has a DB-15 connector for the OxiMax N-600x pulse oximeter and the applicable connector for the Philips monitor. For this interface, Nellcor recommends Nellcor cable part number 902256.

A blank screen on the Philips monitor indicates corrupt data. The Philips monitor detects corrupt data in less than 100 milliseconds. In the Philips mode of operation, the OxiMax N-600x pulse oximeter automatically sets the interface baud rate to 19200 bits per second (bps).

Managing the Data Port

Data Printout Information

Printing Oximeter Trend Data

Trend information (oximeter and in-sensor event history) can be sent to a personal computer or to a serial printer.



Note:

The protocol settings must be set to ASCII MODE for printing text data.

To print trend data

1. With the oximeter in the normal monitoring mode, connect the serial printer to the oximeter's data port connector, using Nellcor printer cable part number 036341.

Figure 41. Data Port Location



2. Turn on the printer.
3. Press the SETUP softkey on the monitor, and then press the NEXT softkey twice.
4. Press the COMM softkey.
5. Set the BAUD rate to the appropriate number using the ADJUST UP or ADJUST DOWN key.

- Press the SELECT softkey to select PROTOCOL.

Figure 42. Serial Port Setup Screen, Protocol Selection



POX_10035_A

- Set the PROTOCOL to ASCII for text printing using the ADJUST UP or ADJUST DOWN key below the ALARM SILENCE key on the oximeter panel if the protocol is different. For print standards, refer to *Data Port Connectivity*, page 79.
- Press the EXIT softkey.
- Enter the Service Menu by simultaneously pressing and holding the LIGHT softkey and the HELP/CONTRAST button until the service softkeys display.

Figure 43. PARAM and PRINT Service Menu



POX_10174_A

- Press the PRINT softkey to reach the options for TREND, ERRLOG, INSTAT, and INFO printouts.

Figure 44. PRINT Service Menu Options



POX_10177_A

- Select the appropriate printout with the corresponding softkey. For more information about each option, refer to *PRINT Softkey Menu*, page 132.



Note:

Once trend printing begins, printing can only be aborted by turning off the N-600x or the printer.

At the end of the printout, an “Output Complete” line indicates the transmission was successful. If the “Output Complete” line is not present, ignore the data, since it may be corrupted.

Figure 45. Sample ASCII Printout

N600x	VERSION 2.0.4.0	CRC:0000	SpO2 Limit: 85-100%	PR Limit: 40-170BPM
	ADULT 100SAT-S	SPO2 RESP MODE: NORMAL		
TIME	%SPO2	BPM	PA	Status
27-OCT-08 13:41:57	90	60	5	
27-OCT-08 13:41:59	90	60	5	
27-OCT-08 13:42:01	90	60	5	
	Output Complete			

POX_10077_A

Real-Time Output

Real-time data is continuously sent to the data port on the back of the N-600x pulse oximeter.

Patient data can be obtained through the data port by connecting the oximeter data port to a PC or serial printer. When a real-time printout or display is being transmitted to a printer or PC, a new line of data displays every second. Column headings display or print after every 25 lines, or if one of the values in the column heading changes. Readings display at one-second intervals.



Note:

If the data output stops transmitting, turn the power off and back on again or, if the oximeter is connected to a PC, send an XON (Ctrl-q) command to reset the oximeter.

Real-Time Output Data Fields

Here is an example of real-time data output.

Figure 46. Sample Real-Time Data Output (SPD feature not enabled)

N600x VERSION 2.0.4.0					CRC:0000	SpO2 Limit: 85-100% PR Limit: 40-170BPM	
ADULT 100SAT-S					SPO2 RESP MODE: NORMAL		
TIME	%SPO2	BPM	PA	Status			
27-OCT-08 13:41:57	90	60	60	5			
27-OCT-08 13:41:59	90	60	60	5			
27-OCT-08 13:42:01	90	60	60	5			
27-OCT-08 13:42:03	90	60	60	5			
27-OCT-08 13:42:05	90	60	60	5			
27-OCT-08 13:42:07	90	60	60	5			
27-OCT-08 13:42:09	90	60	60	5			
27-OCT-08 13:42:11	90	60	60	5			
27-OCT-08 13:42:13	90	60	60	5			
27-OCT-08 13:42:15	90	60	60	5			
27-OCT-08 13:42:17	90	60	60	5			
27-OCT-08 13:42:19	90	60	60	5			
27-OCT-08 13:42:21	100	190*	51		PH		
27-OCT-08 13:42:23	100	190*	53		PH	LB	
27-OCT-08 13:42:25	100	190*	50		PH	LB	
27-OCT-08 13:42:27	100	090*	50		PH	LB	
27-OCT-08 13:42:29	---	---	---	SD		LB	
27-OCT-08 13:42:31	---	---	---	SD		LB	
27-OCT-08 13:42:33	---	---	---	SD			
27-OCT-08 13:42:35	---	---	---	SD			
27-OCT-08 13:42:37	---	---	---	SD			
27-OCT-08 13:42:39	---	---	---	SD			
N600x VERSION 2.0.4.0					CRC:0000	SpO2 Limit: 85-100% PR Limit: 40-170BPM	
ADULT 100SAT-S					SPO2 RESP MODE: NORMAL		
TIME	%SPO2	BPM	PA	Status			
27-OCT-08 13:42:41	90	60	60	5			
N600x VERSION 2.0.4.0					CRC:0000	SpO2 Limit: 80-100% PR Limit: 40-170BPM	
ADULT 100SAT-S					SPO2 RESP MODE: NORMAL		
TIME	%SPO2	BPM	PA	Status			
27-OCT-08 13:42:43	90	60	60	5			
27-OCT-08 13:42:45	90	60	60	5			

POX_10066_A

1. **Column Headings**—Every 25th line of the data output consists of a column heading. A column heading appears whenever the value within a column heading changes. The example above shows three distinct column heading sets. Starting at the top row, there are 25 lines before the second row of column headings print. The third row of column headings in Figure 46 appear when the operator changes the lower alarm limit from 85 percent to 80 percent.

Figure 47. Sample Standard Column Headings

N600x VERSION 2.0.4.0					CRC:0000	SpO2 Limit: 85-100% PR Limit: 40-170BPM	
ADULT 100SAT-S					SPO2 RESP MODE: NORMAL		
TIME	%SPO2	BPM	PA	Status			

POX_10061_A

2. **Data Source**—Data in the highlighted box represents the model number of the oximeter, in this case the OxiMax N-600x pulse oximeter.

Figure 48. Location of Model Number in Column Headings

N600x	VERSION 2.0.4.0	CRC:0000	SpO2 Limit: 85-100% PR Limit: 40-170BPM	
	ADULT 100SAT-S	SPO2 RESP MODE: NORMAL		
TIME	%SPO2	BPM	PA	Status

POX_10064_A

- Firmware Version**—The next data field displays the firmware level (Version 2.0.4.0) and a firmware verification number (CRC: XXXX). Neither of these numbers should change during normal operation.

Figure 49. Location of Firmware Version in Column Headings

N600x	VERSION 2.0.4.0	CRC:0000	SpO2 Limit: 85-100% PR Limit: 40-170BPM	
	ADULT 100SAT-S	SPO2 RESP MODE: NORMAL		
TIME	%SPO2	BPM	PA	Status

POX_10073_A



Note:

The numbers may change if the oximeter is serviced and receives a firmware upgrade.

- Alarm Limits**—The last data field in the top line indicates the upper and the lower alarm limits for SpO2 and for the pulse rate (PR). In the example above the lower alarm limit for is 85% and the upper alarm limit is 100%. Pulse Rate alarm limits are 40 and 170 bpm. The SatSeconds alarm limit (100SAT-S) displays the SatSeconds alarm setting. In this example, SatSeconds is set to 100.

Figure 50. Location of Alarm Limits in Column Headings

N600x	VERSION 2.0.4.0	CRC:0000	SpO2 Limit: 85-100% PR Limit: 40-170BPM	
	ADULT 100SAT-S	SPO2 RESP MODE: NORMAL		
TIME	%SPO2	BPM	PA	Status

POX_10076_A

- Monitor Mode**—The first field of the second line identifies the monitor (ADULT or NEONATE) mode.

Figure 51. Location of Monitor Mode in Column Headings

N600x	VERSION 2.0.4.0	CRC:0000	SpO2 Limit: 85-100% PR Limit: 40-170BPM	
	ADULT 100SAT-S	SPO2 RESP MODE: NORMAL		
TIME	%SPO2	BPM	PA	Status

POX_10072_A

- Response Mode**—The second field of the second line identifies the SatSeconds alarm limit and SpO2 response (NORMAL or FAST) mode. The response mode may impact the SPD alarm behavior.

Figure 52. Location of and Response Mode in Column Headings

N600x	VERSION 2.0.4.0	CRC:0000	SpO2 Limit: 85-100% PR Limit: 40-170BPM	
	ADULT 100SAT-S	SPO2 RESP MODE: NORMAL		
TIME	%SPO2	BPM	PA	Status

POX_10074_A

- Data Column Headings**—Actual column headings are in the last row of the column heading line.

Figure 53. Location of Data Column Headings

N600x	VERSION 2.0.4.0	CRC:0000	SpO2 Limit: 85-100% PR Limit: 40-170BPM	
	ADULT 100SAT-S	SPO2 RESP MODE: NORMAL		
TIME	%SPO2	BPM	PA	Status

POX_10062_A

8. **Patient data**—Presented in the chart from left to right.

- Time the patient data was recorded
- Current SpO2 value
- Current Pulse Rate (BPM)
- Current Pulse Amplitude (PA)
- Operating status of the oximeter

a. **Time**—The Time column displays the value of the real-time clock.

Figure 54. Location of Time Stamp

TIME	%SPO2	BP	PA	Status
27-OCT-08 13:41:57	100	190*	50	PH

POX_10075_A

b. **Patient Data**—Parameter values are displayed directly beneath the heading for each parameter. In this example, the %SpO2 is 100 and the pulse rate is 190 beats per minute. The "*" next to the 190 indicates that 190 beats per minute is outside of the alarm limits, indicated in the top row, for pulse rate. If no data for a parameter is available, three dashes [- - -] display. PA represents the pulse amplitude value, in which the number can range from 0 to 254. There are no alarm parameters for this value. It can be used for trending information as an indication of a change in pulse volume, relative pulse strength, or circulation.

Figure 55. Location of Patient Data

N600x VERSION 2.0.4.0		CRC:0000		SpO2 Limit: 85-100% PR Limit: 40-170BPM	
ADULT 100SAT-S		SPO2 RESP MODE: NORMAL			
TIME	%SPO2	BP	PA	Status	
27-OCT-08 13:41:57	100	190*	50	PH	

POX_10060_A



Note:

A sensor disconnect causes three dashes [- - -] to be displayed in the patient data section of the display or printout.

c. **Operating Status**—The Status column indicates alarm conditions and operating status of the oximeter. In this example, "PH" (Pulse High) indicates the pulse rate upper alarm limit has been exceeded. A complete listing of the status codes is listed below. As many as four codes can be displayed at one time in the Status column.

Figure 56. Location of Operating Status Data

N600x VERSION 2.0.4.0		CRC:0000		SpO2 Limit: 85-100% PR Limit: 40-170BPM	
ADULT 100SAT-S		SPO2 RESP MODE: NORMAL			
TIME	%SPO2	BP	PA	Status	
27-OCT-08 13:41:57	100	190*	50	PH	

POX_10068_A

Table 17. Status Code Definitions

Code	Definition
AO	Alarm Off
AS	Alarm Silence
BU	Battery in Use

Table 17. Status Code Definitions

Code	Definition
LB	Low Battery
LM	Loss of Pulse with Signal Artifact
LP	Loss of Pulse
ID	Signal Artifact Detected
MO	Signal Artifact
PH	Pulse Rate Upper Limit Alarm
PL	Pulse Rate Lower Limit Alarm
PS	Pulse Search
SH	Saturation Upper Limit Alarm
SL	Saturation Lower Limit Alarm
SD	Sensor Disconnect
SO	Sensor Off



Caution

Signal artifacts, secondary to a variety of external factors may compromise the presence or accuracy of the displayed oximeter values.

Additional Data Fields with SPD feature enabled

The SPD feature adds two fields to the column heading and an extra column to the far right of the displayed data or print-out (not provided in real-time output) when using the default ASCII protocol.

1. **Pulse Rate (PR) Alarm Delay Limit**—The oximeter monitors the pulse rate and sounds an alarm if the pulse rate exceeds or drops below expected limits. A higher pulse rate alarm delay threshold allows for momentary artifacts without issuing an alarm. Settings include 0PR Delay, 5PR Delay, or 10PR Delay.
2. **SPD Settings**—OxiMax SPD™ Alert (SPD) setting options.
 - a. **SPD Sensitivity Setting**—Establishes a threshold at which patterns of desaturation trigger an alarm.
 - **Very Sensitive**—The default setting of one (1) is very sensitive to desaturation patterns.
 - **Moderately Sensitive**—A setting of two (2) is moderately sensitive to desaturation patterns.
 - **Less Sensitive**—A setting of three (3) is the least sensitive and allows for more interference and other artifacts when monitoring patterns of desaturation.
 - b. **SPD Alarm Type**—Visual alarm only or both audio and visual SPD alarms
 - c. **SPD Index**—The Time column displays the SPD Index, which ranges from a value of 0 to 31. Used by Nellcor staff.

Using the Nurse Call Interface

Nurse Call Feature



WARNING

Do not use the nurse call feature as the primary source of alarm notification. The audible and visual alarms of the pulse oximeter, used in conjunction with clinical signs and symptoms, are the primary sources for notifying medical personnel that an alarm condition exists.



WARNING

The nurse call feature of the OxiMax N-600x pulse oximeter is operational when the oximeter is powered by AC power or battery power. However, the nurse call feature does not function when oximeter alarms are silenced.

The nurse call feature of the OxiMax N-600x pulse oximeter allows caregivers to remotely monitor patient alarms and works in conjunction with the nurse call system of your institution. Access this feature through data port pins 7, 8, 10, 11, or 15.

Figure 57. Data Port Pin Layout

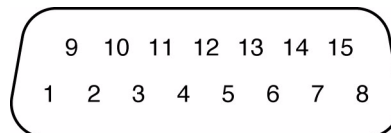

POX_10063_A

The oximeter provides two different types of nurse call interfaces: an RS-232 level and relay closure. The RS-232 level nurse call function operates when the oximeter is connected to AC power or on battery. The relay-based nurse call function is available when the oximeter is operating either on AC power or on battery power.

When enabled, audible alarms signal the remote location. If the audible alarm has been turned off or silenced, the nurse call function is also disabled.

Obtain the RS-232 Nurse Call signal (pins 5 and 11) by connecting to the data port. It is in the form of a positive or negative voltage chosen by the user. See *Data Port Pinouts*, page 80 for complete information.

Pin 11 on the data port is the RS-232 level nurse call signal and pin 5 or 10 is ground (See Figure 38 on page 81). With no alarm condition, the voltage between pins 10 and 11 are -5 VDC to -12 VDC, or +5V DC to +12 VDC, depending on the option chosen via the softkeys (either NORM+ or NORM-). With an audible alarm, the output between pins 5 and 11 will reverse polarity.

Pins 7 and 15 provide a relay that closes when an alarm is sounding on the oximeter. Pins 8 and 15 provide a relay that opens when an alarm is sounding. Pin 15 is

common, pin 7 is normally open, and pin 8 is normally closed. See *Rating of Nurse Call Relay*, page 30 for ratings.

Table 18. Nurse Call Relay Pin States

Pin	No Alarm or Alarm Silenced	Audible Alarm	Oximeter Off
7 NO	Open	Closed	Closed
8 NC	Closed	Open	Open

Test the nurse call function prior to using it in your facility and whenever setting up the OxiMax N-600x pulse oximeter in a location that uses nurse call. If an attached OxiMax pulse oximetry sensor is not connected to a patient, the oximeter display reads zeros and the oximeter remains in the Pulse Search Mode for five seconds, then the oximeter displays three dashes [- - -] in the SpO2 and pulse rate area of the screen. One way to test the nurse call function is to create an alarm condition (for example, sensor disconnect) and verify activation of your facility's nurse call system.

Setting Nurse Call RS-232 Polarity

The nurse call polarity can be set to a positive signal (NORM +) on a oximeter alarm condition or a negative signal (NORM -) on a oximeter alarm condition.

To set nurse call polarity

1. With the oximeter in the normal monitoring mode, press the SETUP softkey.
2. Press the NEXT softkey twice and then press the NCALL softkey.

Figure 58. Nurse Call Polarity Screen

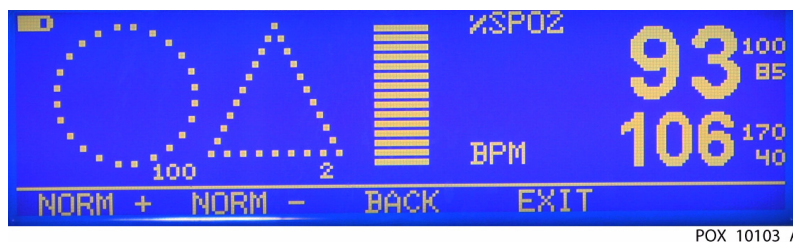

POX_10103_A

3. Press the NORM + softkey OR press the NORM - softkey.
4. Press the EXIT softkey.

Calculating the Analog Voltage Output

The OxiMax N-600x pulse oximeter provides analog outputs for saturation, pulse rate, and the plethysmographic waveform. The output voltage is 0.0 to +1.0 VDC for all three parameters. The voltage decreases as the values for these parameters decrease. If no data for a parameter is available, the output voltage for that parameter is 1.0 VDC.

After the completion of power-on self-test (POST), the oximeter initiates an automatic three-step calibration signal. The calibration signal begins at 0.0 VDC and

holds that point for 15 seconds. It increases to 1.0 VDC and holds that value for 15 seconds. The third part of the calibration signal is a stair step signal. The stair step signal, begins at 0.0 VDC and increases up to 1.0 VDC in 0.1 VDC increments, each held for one (1) second. Select the 0.0 VDC, 1.0 VDC, or stair step signal individually, using the ANALOG softkey menu option.

Figure 59. Analog Pinouts

Pin	VDC Parameter	Parameter Range
6	Saturation	0 - 100%
13	Pulse Rate	0 - 250 bpm
14	Waveform	0 - 254 PAU

The OxiMax N-600x pulse oximeter data port provides analog voltage outputs between pins 6, 13, 14, and ground (pin 10), which can be used to calibrate oximeters such as a chart recorder. The voltage represents a specific measured parameter's current value. The voltage differential varies proportionally from 0.0 to +1.0 VDC as the pin's parameter varies over its full range of values. For example, as the current value of SpO₂ varies from 0% to 100%, the voltage from pin 6 to ground (pin 10) varies from 0.0 to +1.0 VDC. A voltage of 0.94 volts indicates a current SpO₂ value of 94.

Figure 60. Data Port Pin Layout

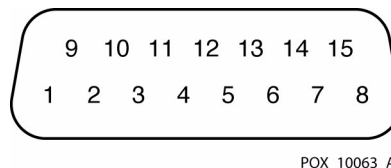

POX_10063_A

To set analog voltage output

1. Press the SETUP softkey.
2. Press the NEXT softkey three times.
3. Press the ANALOG softkey.

Figure 61. Analog Voltage Screen

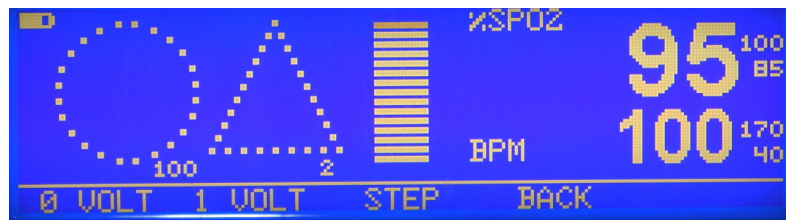

POX_10104_A

- a. **VOLT Options**—Selecting the 0 VOLT or 1 VOLT softkey causes that voltage to appear at pins 6, 13, or 14 as referenced to ground pins 5 and 10.
 - b. **STEP Option**—Selecting the STEP softkey causes the voltage to increase from 0.0 to 1.0 volts at 1/10th-volt increments, with each step lasting at least one second.
4. Press the BACK softkey.

9 Performance Considerations

Overview



WARNING

Pulse oximetry readings and pulse signals can be affected by certain ambient environmental conditions, OxiMax pulse oximetry sensor application errors, and certain patient conditions. See the appropriate sections of the manual for specific safety information.

- *Safety Information, page 9*
- *Performance Considerations, page 97*

Verify the performance of the OxiMax N-600x™ pulse oximeter by following the procedures outlined in *Modifying and Testing the Oximeter*, page 103. A qualified service technician should perform these procedures prior to initial installation in a clinical setting.

Performance Considerations

Primary Considerations

Application issues and certain patient conditions can affect the measurements of the OxiMax N-600x pulse oximeter and cause the loss of the pulse signal.

Oximetry Application Issues

- Incorrect sensor application
- Failure to cover the sensor with opaque material in high ambient light conditions

Patient Conditions

- Dysfunctional hemoglobins
- Poor peripheral perfusion
- Excessive patient activity
- Venous pulsations
- Intravascular dyes, such as indocyanine green or methylene blue
- Dark pigment or externally applied coloring agents (nail polish, dye, pigmented cream)
- Defibrillation

Oximetry Considerations

Pulse Rates

The oximeter only displays pulse rates between 20 and 250 bpm. Detected pulse rates above 250 bpm are displayed as 250. Detected pulse rates below 20 are displayed as a zero (0).

Saturation

The oximeter displays saturation levels between 1% and 100%.

Patient Conditions

Dysfunctional Hemoglobins

Dysfunctional hemoglobins such as carboxyhemoglobin, methemoglobin, and sulphhemoglobin are unable to carry oxygen. SpO₂ readings may appear normal; however, a patient may be hypoxic because less hemoglobin is available to carry oxygen. Further assessment beyond pulse oximetry is recommended.

Anemia

Anemia causes decreased arterial oxygen content. Although SpO₂ readings may appear normal, an anemic patient may be hypoxic. Correcting anemia can improve arterial oxygen content. The oximeter may fail to provide an SpO₂ reading if hemoglobin levels fall below 5 gm/dl.

OxiMax™ Pulse Oximetry Sensor Performance Considerations

Safety Information



WARNING

Pulse oximetry readings and pulse signal can be affected by certain ambient conditions, sensor application errors, and certain patient conditions.



WARNING

Tissue damage can be caused by incorrect application or inappropriate duration of use of an OxiMax pulse oximetry sensor. Inspect the sensor site as directed in the *Directions for Use*.



WARNING

Use only Nellcor-approved OxiMax pulse oximetry sensors and pulse oximetry cables when connecting to the OxiMax sensor connector. Connecting any other cable or sensor influences accuracy of sensor data, which may lead to adverse results.



WARNING

Failure to cover the OxiMax pulse oximetry sensor site with opaque material in high ambient light conditions may result in inaccurate measurements.

Inaccurate Sensor Measurement Conditions

A variety of conditions can cause inaccurate sensor measurements.

- Incorrect application of the OxiMax pulse oximetry sensor
- Placement of the OxiMax pulse oximetry sensor on an extremity with a blood pressure cuff, arterial catheter, or intravascular line
- Ambient light
- Excessive patient activity
- Dark pigment
- Intravascular dyes or externally applied coloring, such as nail polish or pigmented cream
- Failure to cover the OxiMax pulse oximetry sensor site with opaque material in high ambient light conditions

Signal Loss

Loss-of-pulse signal can occur for several reasons.

- The OxiMax pulse oximetry sensor is applied too tightly
- A blood pressure cuff is inflated on the same extremity as the attached OxiMax pulse oximetry sensor
- There is arterial occlusion proximal to the OxiMax pulse oximetry sensor
- Poor peripheral perfusion

Recommended Usage

Select an appropriate OxiMax pulse oximetry sensor, apply it as directed, and observe all warnings and cautions presented in the directions for use accompanying the sensor. Clean and remove any substances such as nail polish from the application site. Periodically check to ensure that the sensor remains properly positioned on the patient.

High ambient light sources such as surgical lights (especially those with a xenon light source), bilirubin lamps, fluorescent lights, infrared heating lamps, and direct sunlight can interfere with the performance of an OxiMax pulse oximetry sensor. To prevent interference from ambient light, ensure that the sensor is properly applied, and cover the sensor site with opaque material.

If patient activity presents a problem, try one or more of the following remedies to correct the problem.

- Verify the OxiMax pulse oximetry sensor is properly and securely applied
- Move the sensor to a less active site
- Use an adhesive sensor that improves patient skin contact
- Use a new sensor with fresh adhesive backing
- Keep the patient still, if possible

If poor perfusion affects performance, consider using the Max-Fast™ adhesive forehead sensor, which provides vastly superior detection in the presence of

vasoconstriction. Max-Fast pulse oximetry sensors work particularly well on supine patients and mechanically ventilated patients. During low perfusion conditions, Max-Fast pulse oximetry sensors reflect changes to the SpO₂ up to 60 seconds earlier than digit sensors. If the Max-Fast pulse oximetry sensor is not available, consider using the OxiMax™ Max-R adhesive nasal sensor. It obtains extremely accurate measurements from a nasal artery supplied by the internal carotid that demonstrates less vasoconstriction than the peripheral vessels. This sensor may obtain measurements even when peripheral perfusion is relatively poor.



10 Oximeter Preventive Maintenance

Overview

This section describes the steps required to maintain, service, and properly clean the OxiMax N-600x™ pulse oximeter. Follow local governing ordinance and recycling instructions regarding the disposal or recycling of the oximeter and its accessories.

Cleaning



WARNING

Do not spray, pour, or spill any liquid on the OxiMax N-600x pulse oximeter, its accessories, connectors, switches, or openings in the chassis.

For surface cleaning and disinfection the oximeter, follow your institution's procedures or the recommended actions below.

- **Surface cleaning**—Use a soft cloth dampened with either a commercial, nonabrasive cleaner or a solution of 70% alcohol in water, lightly wiping the surfaces of the oximeter.
- **Disinfection**—Use a soft cloth saturated with a solution of 10% chlorine bleach in tap water, lightly wiping the surface of the oximeter.

Before attempting to clean an OxiMax™ pulse oximetry sensor, read the *Directions for Use* enclosed with the sensor. Each sensor model has cleaning instructions specific to that sensor. Follow the OxiMax pulse oximetry sensor cleaning and disinfecting procedures in the particular sensor's *Directions for Use*.

Periodic Safety Checks

Perform the following checks every 24 months.

- Replace the battery every 24 months. See *Battery Replacement*, page 170.
- Inspect the equipment for mechanical and functional damage or deterioration.
- Inspect the safety relevant labels for legibility. Contact Nellcor Technical Services, 1.800.635.5267, if labels are damaged or illegible.
- Inspect the internal fuse (F3) for proper value and rating.
- Ensure all user interface keys, cables, and accessories function normally.
- Perform a baseline functional check at least every 24 months.

To perform a baseline functional check:

1. Perform the electrical safety tests detailed in *Modifying and Testing the Oximeter*, page 103. If the unit fails the tests, refer to *Ordering Oximeter Spare Parts*, page 161.
2. Inspect the external fuses for proper value and rating (F1 + F2 = 0.5 amp, 250 volts).



Note:

For extensive, service functional testing, see *Modifying and Testing the Oximeter*, page 103.

11 Modifying and Testing the Oximeter

Overview

This section provides information to trained service technicians on setting institutional defaults, verifying OxiMax N-600x™ pulse oximeter performance, and accessing service functions.



WARNING

Only qualified service personnel should open the oximeter housing, remove and replace components, or make adjustments. If your medical facility does not have a qualified service technician, please contact Nellcor's Technical Services or your local Nellcor representative.

Setting Institutional Defaults (Sample)

Change power-on default values to institutional power-on default values using the oximeter's service mode. Set temporary desired limits in normal operation mode.

Table 19. Institutional Default Settings

Parameter	Possible Setting
Alarms	Allow Off - Yes/No
Alarm Volume	1 to 10 (min. 45dB, max > 85dB)
ALARM SILENCE Duration	30, 60, 90, 120 seconds (Service Mode settings only)
Pulse Beep Volume	0 to 10
Pulse Rate Upper Alarm Limit	Lower Limit plus 1 to 250 BPM
Pulse Rate Lower Alarm Limit	20 BPM to Upper Limit minus 1
Pulse Rate Delay Feature	OFF, 5, 10 seconds
%SpO2 Upper Alarm Limit	Lower Limit plus 1 to 100%
%SpO2 Lower Alarm Limit	Upper Limit minus 1 to 85%
Allow SatSeconds	Yes/No
SatSeconds™ Alarm Management Feature	OFF, 10, 25, 50, 100 SatSeconds
OxiMax SPD™ Alert (SPD) Feature	OFF, 1, 2, 3
SPD Alarm Type	Audible and Visual, Visual Only
Sensor Event Record Type	SpO2, SpO2 + BPM, Default

Table 19. Institutional Default Settings

Parameter	Possible Setting
Sensor Adjust Enable	Yes/No
Nurse Call Priority RS-232	Normally high, normally low
Data Port Mode Available selections depend on firmware version.	ASCII, CLINICAL, PHILIPS,SPDout
Data Port Baud Rate	2400, 9600, 19200

To set institutional defaults:

1. Disconnect the OxiMax pulse oximetry sensor from oximeter.



Note:

If the OxiMax pulse oximetry sensor is not disconnected, the only softkeys on the screen will be PARAM and EXIT.

2. Set desired parameters to the institutional values. Refer to *Adjusting the Factory Default Settings*, page 72, for parameter values.
3. Simultaneously press the LIGHT softkey and the HELP/CONTRAST button until the softkey headings appear.
4. Press the PARAM softkey.

Figure 62. Service Main Menu



5. Press the SAVE softkey.

Figure 63. SAVE Option



- Press the YES softkey. The oximeter sounds three beeps to indicate the defaults have been saved.

Figure 64. Save Default Prompt in Response to SAVE Selection



Performance Verification

Overview

This section discusses the tests used to verify performance following repairs or during routine maintenance. All tests can be performed without removing the OxiMax N-600x pulse oximeter cover. Perform all tests before the battery charge and battery performance checks, then perform both battery checks as the last operation before returning the pulse oximeter to the caregiver. If the pulse oximeter fails to perform as specified in any test, make all repairs necessary to correct the problem before returning the oximeter to the caregiver.

Required Equipment

Table 20. Equipment and Descriptions

Equipment	Description
Digital multimeter (DMM)	Fluke Model 87 or equivalent
Durasensor™ Adult Finger Clip Sensor	DS-100A sensor
OxiMax™ pulse oximetry sensor	MAX-A sensor
Safety analyzer	Must meet current AAMI ESI:1993 & IEC 60601-1:1988 + A1:1991 + A2:1995 specifications
Pulse oximetry cable	DOC-10 cable
Data interface cable	RS-232 cable (optional)
Stop watch	Manual or electronic
Nellcor model SRC-MAX functional oximetry tester	Provides testing for DigiCal compatible oximeters
9-pin to 15-pin D-connector with all pins shorted together	Provides testing for <i>Service Function Menus</i> , page 130

Safety Testing Standards

The OxiMax N-600x pulse oximeter safety tests are performed in accordance with and meet the following standards. Also, see *Product Safety Standards*, page 32.

- IEC 60601-1: 1988 + A1: 1991 + A2: 1995
- EN 60601-1: 1990 + A11: 1993 + A12: 1993 + A13: 1996
- UL 60601-1 1st edition
- CSA C22.2 No. 601.1 M90

Applicable tests for these standards are listed below. Technicians must be familiar with the standards applicable to their respective institution and country. Test equipment and its application must comply with the applicable standards:

- *Ground Integrity*, page 36, for test values.
- *Leakage Current*, page 37, for test values.



Note:

For testing the patient applied risk current, the leakage test lead from the test equipment must be connected to the SpO2 Sensor Port through the DOC-10 pulse oximetry cable using a male 9-pin "D" type connector with all pins shorted together.

During these tests, the oximeter displays the following message:
"RECONNECT/REPLACE SENSOR".

Battery Check



Note:

Replace the battery every 24 months.

Battery Power

To check battery power:

1. Disconnect the oximeter from AC power and verify the AC Power indicator shuts off.
2. Verify the oximeter is operating normally and the Low Battery indicator is off. If the Low Battery indicator is lit, charge the battery.
3. Connect the oximeter to an AC power source and verify the AC Power indicator turns on and the oximeter is operating normally.

Battery Charge



Note:

The battery charge procedure should be performed before oximeter repairs when possible.

-  Ensure the battery is fully charged by inspecting the Battery Fuel Gauge Indicator, which should be completely full, and check the Low Battery Indicator, which should be off. If the fuel gauge is not completely full, or if the Low Battery Indicator is lit, charge the battery by connecting it to AC power. See *Connecting to an AC Power Source*, page 50 and *Using Battery Power*, page 51.

Performance Tests



Note:

This section uses Nellcor factory defaults. If the institution or caregiver using the oximeter customized the defaults, the OxiMax N-600x pulse oximeter displays those customized values. See the RESET option of the *PARAM (Parameters) Softkey Menu*, page 132 to restore Nellcor factory defaults.

Power-On Defaults and Alarm Ranges

Power-On Defaults

Power-up performance tests verify both power-on self-test (POST) and power-on defaults and alarm range limits. For a description of the power-on self-test, see *Power-On Self-Test (POST)*, page 57.



Note:

Power-on defaults are factory settings or defaults set by the institution.



Note:

The descriptions below are based on the default GCF view with SatSeconds and the Saturation Pattern Detection (SPD) feature enabled. The steps for changing an alarm limit are the same for all views.

Adult and Neonate Alarm Range Limits

To test the power-on and alarm range settings:



Note:

When observing or changing alarm limits, a time-out is in effect (approximately ten seconds). If no action is taken within the time-out, the oximeter automatically returns to the monitoring display.

Testing Upper and Lower %SpO₂ and BPM Limits

1. Turn on the oximeter by pressing the ON/STANDBY button.
2. Press the LIMITS softkey.
3. Ensure the oximeter emits a single beep. A display of the alarm limits replaces the Pleth display. The graphic below is for adult limits, not neonate limits. The selected Upper Alarm

Limit for %SpO2 indicates an alarm limit of "100" or the value set by the institution or caregiver as the default setting.

Figure 65. Adult Limits Default Settings



4. Press and hold the ADJUST DOWN button. Verify the selected number for %SpO2 Upper Alarm Limit decreases to a minimum of "86."



Note:

A decimal point next to the value in the display indicates the alarm limits have been changed from the factory default values.

5. Press the SELECT softkey. Verify the oximeter emits a single beep and the %SpO2 Lower Alarm Limit of "85" (or the institutional default setting) is selected.

Figure 66. Testing Adult %SpO2 Lower Limits



6. Press and hold the ADJUST DOWN button. Verify the %SpO2 Lower Alarm Limit display reduces to a minimum of "20."
7. Press and hold the ADJUST UP button. Verify the %SpO2 Lower Alarm Limit display cannot be raised past the Lower Alarm Limit setting of "85."
8. Press the SELECT softkey twice, bypassing the SAT-S option. Verify the oximeter emits a beep after each keystroke. The selected Pulse Upper Alarm Limit should be "170."

Figure 67. Testing Adult Upper BPM Limits



9. Press and hold the ADJUST DOWN button. Verify the minimum displayed value is "41" for the BPM Upper Alarm Limit.

10. Press the SELECT softkey. Verify the selected Pulse Rate Lower Alarm Limit display indicates an alarm limit of "40."
11. Press and hold the ADJUST DOWN button. Verify the selected Pulse Rate Lower Alarm.
12. Verify the limit display decreases to a minimum of "30."

Figure 68. Testing Adult Lower BPM Limits



13. Press and hold the ADJUST UP button. Verify the selected Pulse Rate Lower Alarm Limit display cannot be adjusted above the Pulse Rate Lower Alarm Limit of "40."
14. Press the ON/STANDBY button to turn the oximeter off.
15. Press the ON/STANDBY button to turn the oximeter back on.
16. Press the LIMITS softkey.
17. Verify the %SpO2 Upper Alarm Limit display indicates an alarm limit of "100."
18. Verify the %SpO2 Lower Alarm Limit display indicates an alarm limit of "85."

Testing SatSeconds, Saturation Pattern Detection, and Pulse Rate Delay Features

1. Press the ON/STANDBY button to turn the oximeter back on.
2. Press the LIMITS softkey.
3. Press the SELECT softkey three times. Verify the SatSeconds SAT-S alarm is selected.
4. Confirm the SatSeconds SAT-S alarm threshold is set to 100 if the SPD feature is enabled and set to OFF if the SPD feature is not enabled.
5. Press the ADJUST UP button repeatedly until the SatSeconds alarm display cycles from OFF through 10, 25, 50, 100, and back to OFF.

Figure 69. Testing Adult SatSeconds Thresholds



6. Press the SELECT softkey once. Confirm the SPD feature is selected.
7. Confirm the SPD alarm is set to 1 if the SPD feature is enabled.

8. Press the ADJUST UP button repeatedly until the SPD alarm threshold cycles from 2 to 3, from 3 to OFF, and back to 1.

Figure 70. Testing Saturation Pattern Detection Thresholds

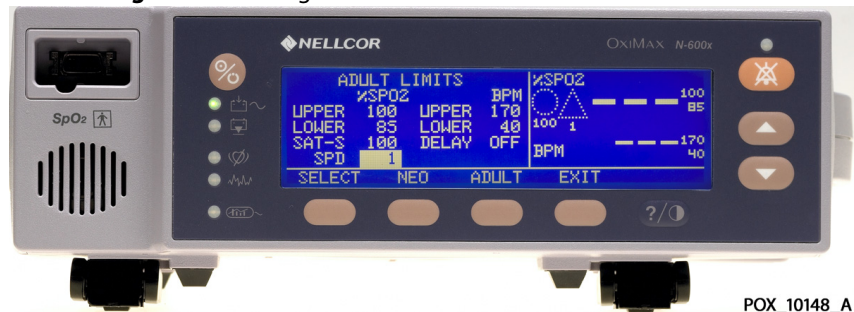

9. Press the SELECT softkey three times. Confirm the Pulse Rate Delay feature is selected.
10. Confirm the Pulse Rate Delay is set to OFF.
11. Press the ADJUST UP button repeatedly until the Pulse Rate Delay alarm threshold cycles from OFF through 5, 10, and back to OFF.

Figure 71. Testing Pulse Rate Delay Thresholds



12. Press the ON/STANDBY button to turn the oximeter off.
13. Press the ON/STANDBY button to turn the oximeter back on.
14. Press the LIMITS softkey.
15. Verify SatSeconds indicates an alarm limit of "100," Saturation Pattern Detection (SPD) indicates a sensitivity setting of "1," and Pulse Rate Delay is OFF.
16. Press the ON/STANDBY button to turn the oximeter off.

Operational Setup

Operational Setup procedures confirm settings for and allow configuration of the listed parameters.

- *Battery Charge*, page 106
- *Alarms and Alarm Silence*, page 111
- *Alarm Volume Control*, page 113
- *Pulse Tone Volume Control*, page 114
- *Using the Analog Output*, page 114

Alarms and Alarm Silence

Figure 72. SpO₂ Sensor Port



POX_10004f_A

To adjust the alarms and alarm silence options:

1. Connect the DOC-10 pulse oximetry cable to the oximeter's SpO₂ Sensor Port.
2. Connect the OxiMax DS-100A sensor to the DOC-10 cable, then to a finger.
3. Press the ON/STANDBY button to turn the oximeter on.
4. Press SETUP and then VIEW.
5. Press the PLETH softkey. Verify the %SpO₂ and BPM indicate the SpO₂ and pulse rate.
6. Press the LIMITS softkey.
7. Press the SELECT softkey to select %SpO₂ Lower Alarm Limit.
8. Press the ADJUST UP button until the %SpO₂ Lower Alarm Limit indicates 99.

Figure 73. Adult %SpO₂ Lower Alarm Limit of 99



POX_10140_A

9. Press the SELECT softkey four consecutive times to select Pulse Rate Lower Alarm Limit.
10. Press the ADJUST UP button until the Pulse Rate Lower Alarm Limit indicates 160.

Figure 74. Adult Lower BPM Alarm Limit of 160



POX_10138_A

11. Confirm the following oximeter results:
 - a. The waveform tracks the pulse rate.
 - b. The Pulse Tone is audible.
 - c. The SpO₂ and pulse rate are flashing in the %SpO₂ and BPM displays.
 - d. The Audible Alarm sounds, indicating both parameters have violated the alarm limits.
12. Press and hold the ALARM SILENCE button until the display indicates "60 SEC."

Figure 75. ALARM SILENCE setting of 60 seconds



13. Continue to press the ALARM SILENCE button. Press the ADJUST UP button until "120" appears in the %SpO₂ display.

Figure 76. ALARM SILENCE setting of 120 seconds



14. Press the ALARM SILENCE button.
15. With the oximeter's alarm silenced, verify the following:
 - a. Alarm remains silenced for 120 seconds
 - b. Alarm Silence indicator lights
 - c. %SpO₂ and BPM displays continue to flash
 - d. Pulse tone is audible
 - e. Audible alarm returns in approximately 120 seconds
16. Press and hold the ALARM SILENCE button until the oximeter screen indicates "60 SEC." Continue to press the ALARM SILENCE button and press the ADJUST DOWN button until "30" appears in the %SpO₂ display.



Note:

"OFF" will only be displayed if the "ALLOW OFF" option was enabled in the Service menu. See *Service Function Menus*, page 130.

17. Press the ADJUST UP button. Verify the displays indicate 60 SEC, 90 SEC, 120 SEC, and OFF. Release the ADJUST UP button when the display indicates "OFF."
18. Press and release the ALARM SILENCE button. Verify the oximeter's ALARM SILENCE indicator flashes.
19. Wait approximately three minutes.
20. Verify the oximeter's alarm does not return. After three minutes, the oximeter's ALARM SILENCE reminder sounds three times, at approximately three minute intervals.

Alarm Volume Control

After adjusting the alarm duration, perform the following alarm volume test procedure.



Note:

The alarm mode is still set to "OFF" unless the oximeter has been power cycled, when default settings are reinstated.

To test the alarm volume:

Set the volume level (1-10) of the alarm. A value of "1" is quiet, a "10" is loud. The default volume level is set to "7."

1. Press and hold the ALARM SILENCE button and verify the following:
 - a. The oximeter displays "OFF" or the default value for approximately three seconds.



Note:

If the ALARMS menu has the ALLOW OFF? option set to YES, the display immediately shows "60 SEC," with a default volume setting of seven.

- a. After three seconds, a steady tone is audible at the default alarm volume setting and the display indicates VOL 7.

Figure 77. ALARM VOLUME default setting of 7



POX_10141_A

2. While pressing the ALARM SILENCE button, press the ADJUST DOWN button until the alarm volume setting displays Vol 1. Verify the volume of the alarm decreases.

Figure 78. ALARM VOLUME setting of 1



3. Continue pressing the ALARM SILENCE button. Press the ADJUST UP button to increase the alarm volume setting to a maximum value of 10. Verify the volume increases.
4. Continue pressing the ALARM SILENCE button while pressing the ADJUST DOWN button to a comfortable audio level.
5. Release the ALARM SILENCE button. The tone discontinues.

Pulse Tone Volume Control

Adjust the pulse tone volume after adjusting the *Alarm Volume Control*, page 113.

To set the pulse tone volume:

1. Press the ADJUST UP button and verify the sound level of the beeping pulse tone volume increases.
2. Press the ADJUST DOWN button and verify the sound level of the beeping pulse tone is silent.
3. Press the ADJUST UP button to return the beep volume to a comfortable audible level.
4. Take off and disconnect the Oximax DS-100A finger sensor, then disconnect the DOC-10 cable from the oximeter.

Using the Analog Output

Figure 79. Data Port Connector

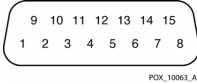

To set the analog output settings:

1. Connect the negative lead of a voltmeter to pin 10 and the positive to lead pin 6 of the Data Port Connector on the back of the oximeter.
2. Press the SETUP softkey.
3. Press the NEXT softkey three consecutive times.
4. Press ANALOG and then the 1 VOLT softkey.

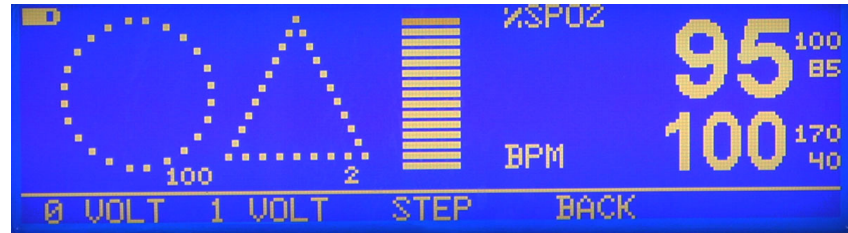
Figure 80. ANALOG Menu

5. Confirm the oximeter's output voltage is $+1.0 \pm 0.025$ VDC, verifying the analog SpO₂ function.
6. Leave the negative lead connected to pin 10 and verify 1.0 ± 0.025 VDC on pins 13 and 14, verifying the oximeter's BPM and Pleth functions.

**Note:**

If step 6 takes more than two minutes to complete, the analog output times out. Repeat steps 2 through 6 to initiate the analog output.

7. Move the positive lead back to pin 6.
8. Press the SETUP softkey.
9. Press the NEXT softkey three consecutive times.
10. Press ANALOG and then the 0 VOLT softkey.
11. Verify the oximeter's output voltage is $+0.0 \pm 0.025$ VDC.
12. Leave the negative lead connected to pin 10 and verify 0.0 ± 0.025 VDC on pins 13 and 14.

**Note:**

If step 12 takes more than two minutes to complete, the analog output times out. Repeat steps 7 through 12 to initiate the analog output.

13. Disconnect the voltmeter from the oximeter.

Overall Performance Check

The following tests provide an overall performance check of the system.

- *LED Excitation Test*, page 116
- *Operation with a Live Subject*, page 117

LED Excitation Test

The LED Excitation Test utilizes normal system components to test circuit operation. Use a OxiMax™ Max-A pulse oximetry sensor to examine LED intensity control. The test uses the red sensor LED to verify intensity modulation controlled by the LED intensity control circuit.

Figure 81. SpO₂ Sensor Port



POX_10004f_A

To test the circuit operation:

1. Connect the oximeter to an AC power source.
2. Connect a DOC-10 pulse oximetry cable to the oximeter SpO₂ Sensor Port.
3. Connect a Max-A pulse oximetry sensor to the OxiMax sensor input cable.
4. Press the ON/STANDBY button to turn the oximeter on.
5. Leave the Max-A pulse oximetry sensor open with the LEDs and photo detector visible.
6. After the oximeter completes a normal power-on sequence, verify the Max-A pulse oximetry sensor LED is brightly lit.
7. Slowly move the Max-A optical sensor LED in proximity to the photo detector element of the Max-A pulse oximetry sensor on the opposing side of the clip, closing the sensor slowly.
8. Verify the LED intensity decreases as the LED approaches the optical sensor.
9. Open the Max-A pulse oximetry sensor and notice the LED intensity increases.
10. Repeat step 8 and the intensity continues to decrease. This variation is an indication the microprocessor is in proper control of LED intensity.
11. Press the ON/STANDBY button to turn off the oximeter.

Operation with a Live Subject

Patient monitoring involves connecting the Durasensor™ DS-100A pulse oximetry sensor to a live subject for a qualitative test.

Figure 82. SpO₂ Sensor Port



POX_10004f_A

To test using a live subject:

1. Ensure the oximeter is connected to an AC power source.
2. Connect a DOC-10 pulse oximetry cable to the oximeter SpO₂ Sensor Port.
3. Connect the DS-100A pulse oximetry sensor to the DOC-10 pulse oximetry cable.
4. Attach the sensor to a live subject as recommended in the OxiMax pulse oximetry sensor's *Directions For Use*.
5. Press the ON/STANDBY button to turn the oximeter on and verify the oximeter is operating.
6. The oximeter should stabilize on the subject's physiological signal in about 15 to 30 seconds. Verify the oxygen saturation and pulse rate values are reasonable for the subject.

Pulse Oximetry Functional Tests

These tests utilize the pulse oximetry functional tester (Nellcor model SRC-MAX) to verify the performance of the oximeter.

Once the functional tester is attached to the cable and the unit is turned on, complete all of the tests in sequence, beginning with BPM, then %SpO₂, then Modulation, and finally Light Level.

Figure 83. SRC-MAX OxiMax Oximetry Tester

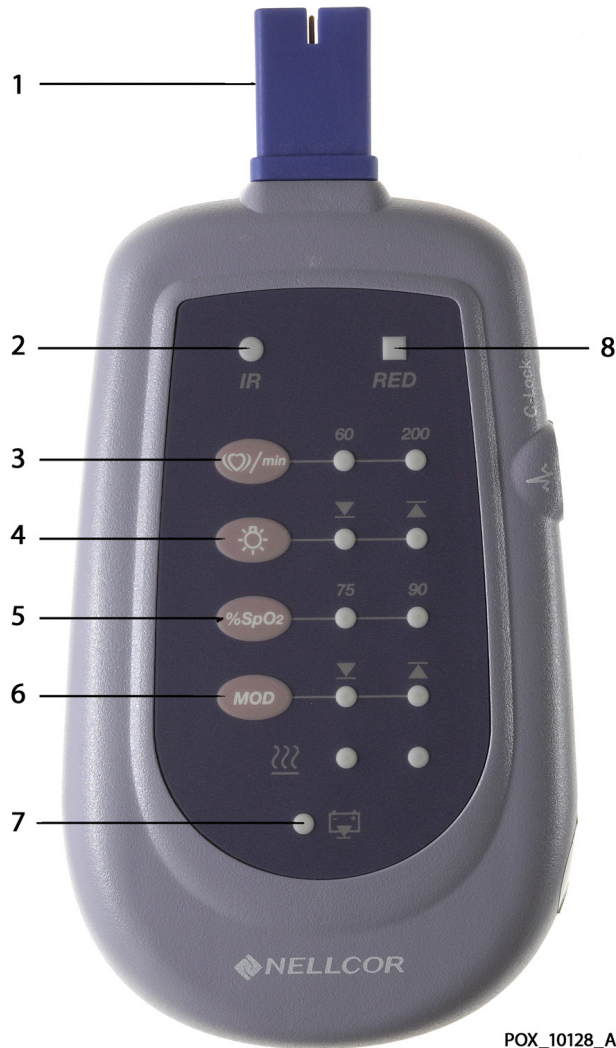

POX_10128_A

Table 21. SRC-MAX Callouts

1. DOC-10 Cable Connector	5. %SpO ₂ Select Button
2. Infrared LED Drive Indicator	6. % Modulation Select Button
3. Pulse Rate Selection Button	7. Battery Low Indicator
4. Light Level Selection Button	8. Red LED Drive Indicator

Overview

The SRC-MAX functional tester enables qualified technicians to functionally test Nellcor OxiMax technology-based oximeters and OEM OxiMax technology-based

oximeters. The following table provides a brief description of each test. Use the PLETH view for all functional testing.

Table 22. Functional Tests Options

Tests	Descriptions
BPM Test	The test procedure simulates an OxiMax pulse oximetry sensor attached to a patient indicating a pulse rate of 60 BPM and 200 BPM.
%SpO2 Test	The test procedure simulates an OxiMax pulse oximetry sensor attached to a patient indicating a 75% blood oxygen saturation and 90% blood oxygen saturation.
Modulation Level Test	The test procedure simulates an OxiMax pulse oximetry sensor attached to a patient indicating low and high pulse strength.
Light Level Test	The test procedure simulates an OxiMax pulse oximetry sensor attached to a patient indicating low and high light level passing through the patient at the sensor site.



Note:

The SRC-MAX selectable indicator LEDs may extinguish if there is a delay in proceeding through the above tests. This is normal operation in order to increase the battery time.



Note:

Pressing a button on the SRC-MAX during the test procedures may be requested, changing a certain parameter. If the SRC-MAX LEDs are not lit, press the button twice. Pressing the button once causes the indicators to relight and pressing twice initiates the change.

BPM Test

1. With the oximeter turned off, connect the DOC-10 pulse oximetry cable to the sensor port.
2. Connect the SRC-MAX tester to the other end of the DOC-10 cable.
3. Turn on the oximeter by pressing the ON/STANDBY button. Wait for the oximeter to complete its self-check.

4. Select the PLETH view by pressing the following softkeys in sequence: SETUP, VIEW, and then PLETH to view the pleth display.

Figure 84. PLETH Display with SRC-MAX tester-generated waveform

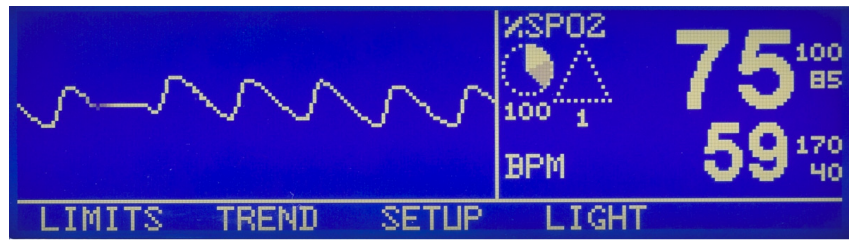

POX_10155_A

- a. Active audio alarm.
 - b. Flashing %SpO2 indication between 73 and 77 inclusive.
 - c. BPM indication between 57 and 63 inclusive.
 - d. Pulse waveform of approximately 1/2-inch peak to peak (P-T-P) amplitude. Actual amplitude may vary but will be a reference for low pulse amplitude/low light patients.
5.  Press the SRC-MAX PULSE RATE selection button. The SRC-MAX PULSE RATE 200 LED lights. The oximeter registers BPM increases and stabilizes to a value between 197 to 203 BPM inclusive.

Figure 85. PLETH Display with SRC-MAX increase to 200 BPM



POX_10157_A

- a. Active audio alarm.
- b. Flashing %SpO2 indication between 73 and 77 inclusive.
- c. Flashing BPM indication between 197 and 203.
- d. Pulse waveform of approximately 1/2-inch P-T-P amplitude. Actual amplitude may vary but references low pulse amplitude/low light patients.



6. Press the SRC-MAX PULSE RATE selection button. The SRC-MAX PULSE RATE 60 LED lights. The oximeter registers BPM decreases and stabilizes to a value between 67 to 73 BPM inclusive.

Figure 86. PLETH Display with SRC-MAX decrease to 60 BPM



- a. Active audio alarm.
 - b. Flashing %SpO2 indication between 73 and 77 inclusive.
 - c. BPM indication between 57 and 63 inclusive.
 - d. Pulse waveform of approximately 1/2-inch P-T-P amplitude. Actual amplitude may vary but will be a reference for low pulse amplitude/low light patients.
7. Turn off the oximeter.

SpO2 Test

1. With the oximeter turned off, connect the DOC-10 pulse oximetry cable to the sensor port.
2. Connect the SRC-MAX tester to the other end of the DOC-10 cable.
3. Turn on the oximeter by pressing the ON/STANDBY button. Wait for the oximeter to complete its self-check.
4. Select the PLETH view by pressing the following softkeys in sequence: SETUP, VIEW, and then PLETH to view the pleth display.

Figure 87. PLETH Display with SRC-MAX tester-generated waveform



- a. Active audio alarm.
- b. Flashing %SpO2 indication between 73 and 77 inclusive.
- c. BPM indication between 57 and 63 inclusive.
- d. Pulse waveform of approximately 1/2-inch peak to peak (P-T-P) amplitude. Actual amplitude may vary but will be a reference for low pulse amplitude/low light patients.

5. Press the SRC-MAX %SpO₂ selection button. The SRC-MAX %SpO₂ 90 LED lights. The oximeter displays three dashes [- - -] until the %SpO₂ stabilizes at a value between 88 and 92 inclusive.

Figure 88. PLETH Display with SRC-MAX increase in %SpO₂ to 90

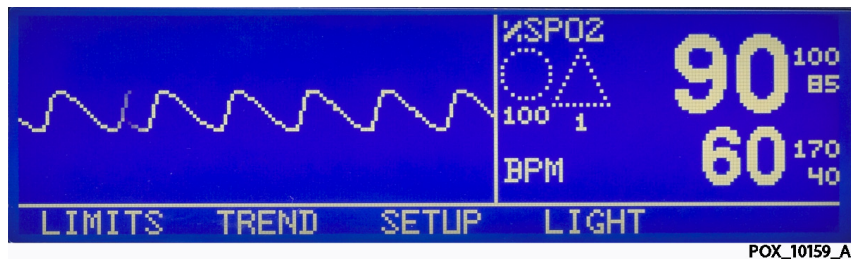

- a. No audio alarm.
 - b. %SpO₂ indication between 88 and 92 inclusive.
 - c. BPM indication between 57 and 63 inclusive.
 - d. Pulse waveform of approximately 1/2-inch P-T-P amplitude. Actual amplitude may vary but will be a reference for low pulse amplitude/low light patients.
6. Press the SRC-MAX %SpO₂ selection button. The SRC-MAX %SpO₂ 75 LED lights. The oximeter displays three dashes [- - -] until stabilizing at a value between 73 and 77 inclusive.

Figure 89. PLETH Display with SRC-MAX decrease in %SpO₂ to 75

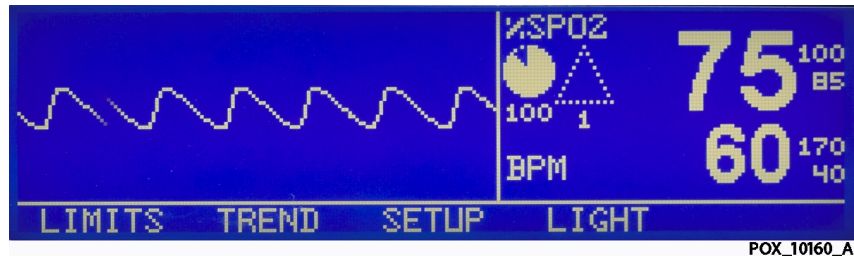

- a. Active audio alarm.
- b. Flashing %SpO₂ indication between 73 and 77 inclusive.
- c. BPM indication between 57 and 63 inclusive.
- d. Pulse waveform of approximately 1/2-inch P-T-P amplitude. Actual amplitude may vary but will be a reference for low pulse amplitude/low light patients.

Modulation Level Test

1. With the oximeter turned off, connect the DOC-10 pulse oximetry cable to the sensor port.
2. Connect the SRC-MAX tester to the other end of the DOC-10 cable.
3. Turn on the oximeter by pressing the ON/STANDBY button. Wait for the oximeter to complete its self-check.

4. Select the PLETH view by pressing the following softkeys in sequence: SETUP, VIEW, and then PLETH to view the pleth display.

Figure 90. PLETH Display with SRC-MAX tester-generated waveform



POX_10155_A

- a. Active audio alarm.
 - b. Flashing %SpO2 indication between 73 and 77 inclusive.
 - c. BPM indication between 57 and 63 inclusive.
 - d. Pulse waveform of approximately 1/2-inch peak to peak (P-T-P) amplitude. Actual amplitude may vary but will be a reference for low pulse amplitude/low light patients.
5. Press the SRC-MAX MODULATION selection button. The SRC-MAX MODULATION  LED lights. The oximeter pulse amplitude waveform initially increases in amplitude and then stabilize at P-T-P amplitude of approximately 1-inch.

Figure 91. PLETH Display with SRC-MAX increase in modulation



POX_10160_A

- a. Active audio alarm.
- b. Flashing %SpO2 indication between 73 and 77 inclusive.
- c. BPM indication between 57 and 63 inclusive.
- d. Pulse waveform of approximately 1-inch P-T-P amplitude. Actual amplitude may vary but will be a reference for high pulse amplitude/low light patients.

6. Press the SRC-MAX PULSE RATE selection button. The SRC-MAX PULSE RATE 200 LED lights. The oximeter registers BPM increases and stabilizes to a value between 197 and 203 inclusive.

Figure 92. PLETH Display with SRC-MAX increase to 200 BPM with modulation

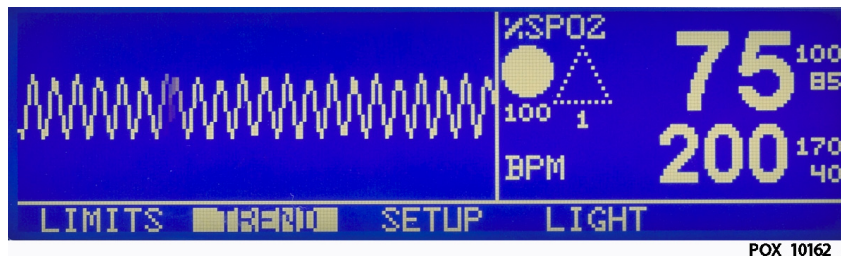

POX_10162_A

- a. Active audio alarm.
 - b. Flashing %SpO2 indication between 73 and 77 inclusive.
 - c. Flashing BPM indication between 197 and 203 inclusive.
 - d. Pulse waveform of approximately 1-inch P-T-P amplitude. Actual amplitude may vary but will be a reference for high pulse amplitude/low light patients.
7. Press the SRC-MAX PULSE RATE selection button. The SRC-MAX PULSE RATE 60 LED lights. The oximeter registers the pulse rate decreases and stabilizes at a value between 57 and 63 inclusive.

Figure 93. PLETH Display with SRC-MAX decrease to 60 BPM with modulation



POX_10163_A

- a. Active audio alarm.
- b. Flashing %SpO2 indication between 73 and 77 inclusive.
- c. BPM indication between 57 and 63 inclusive.
- d. Pulse waveform of approximately 1-inch P-T-P amplitude. Actual amplitude may vary, but can be used as a reference for high pulse amplitude/low light patients.

8. Press the SRC-MAX %SpO₂ selection button. The SRC-MAX %SpO₂ 90 LED lights. The oximeter displays three [- - -] dashes until the %SpO₂ stabilizes to a value between 88 and 92 inclusive.

Figure 94. PLETH Display with SRC-MAX increase in %SpO₂ of 90 with modulation



- No active audio alarm.
 - %SpO₂ indication between 88 and 92 inclusive.
 - BPM indication between 57 and 63 inclusive.
 - Pulse waveform of approximately 1-inch P-T-P amplitude. Actual amplitude may vary, but can be used as a reference for high pulse amplitude/low light patients.
9. Press the SRC-MAX %SpO₂ selection button. The SRC-MAX %SpO₂ 75 LED lights. The oximeter displays three dashes [- - -] and stabilizes at a value between 73 and 77 inclusive.

Figure 95. PLETH Display with SRC-MAX increase in %SpO₂ of 75 with modulation



- Active audio alarm.
- Flashing %SpO₂ indication between 73 and 77 inclusive.
- BPM indication between 57 and 63 inclusive.
- Pulse waveform of approximately 1-inch P-T-P amplitude. Actual amplitude may vary, but can be used as a reference for high pulse amplitude/low light patients.

MOD

- Press the SRC-MAX MODULATION selection button. The SRC-MAX MODULATION  LED lights. The oximeter pulse amplitude waveform decreases in amplitude.

Figure 96. PLETH Display with SRC-MAX decrease in modulation



- Active audio alarm.
 - Flashing %SpO2 indication between 73 and 77 inclusive.
 - BPM indication between 57 and 63 inclusive.
 - Pulse waveform of approximately 1/2-inch P-T-P amplitude. Actual amplitude may vary, but can be used as a reference for low pulse amplitude/low light patients.
- Turn off the oximeter.

Light Level Test

- With the oximeter turned off, connect the DOC-10 pulse oximetry cable to the sensor port.
- Connect the SRC-MAX tester to the other end of the DOC-10 cable.
- Turn on the oximeter by pressing the ON/STANDBY button. Wait for the oximeter to complete its self-check.
- Select the PLETH view by pressing the following softkeys in sequence: SETUP, VIEW, and then PLETH to view the pleth display.

Figure 97. PLETH Display with SRC-MAX tester-generated waveform



- Active audio alarm.
- Flashing %SpO2 indication between 73 and 77 inclusive.
- BPM indication between 57 and 63 inclusive.
- Pulse waveform of approximately 1/2-inch peak to peak (P-T-P) amplitude. Actual amplitude may vary but will be a reference for low pulse amplitude/low light patients.



5. Press the SRC-MAX LIGHT LEVEL selection button. The SRC-MAX LIGHT LEVEL \blacktriangle LED lights. The oximeter pulse amplitude waveform initially flatlines and stabilizes at the same amplitude.

Figure 98. PLETH Display with SRC-MAX increase in light



POX_10167_A



Note:

Flat-lining is the only indication of a light change at the measurement site. If the oximeter recovers and displays normally, this is an indication of proper operation with light changes.

- a. Active audio alarm.
- b. Flashing %SpO₂ indication between 73 and 77 inclusive.
- c. BPM indication between 57 and 63 inclusive.
- d. Pulse waveform of approximately 1/2-inch P-T-P amplitude. Actual amplitude may vary, but can be used as a reference for low pulse amplitude/high light patients.



6. Press the SRC-MAX PULSE RATE selection button. The SRC-MAX PULSE RATE 200 LED lights. The oximeter registers the BPM increases and stabilizes at a value between 197 and 203 inclusive.

Figure 99. PLETH Display with SRC-MAX increase to 200 BPM with high light condition



POX_10168_A

- a. Active audio alarm.
- b. Flashing %SpO₂ indication between 73 and 77 inclusive.
- c. Flashing BPM indication between 197 and 203 inclusive.
- d. Pulse waveform of approximately 1/2-inch P-T-P amplitude. Actual amplitude may vary, but can be used as a reference for low modulation/high light indications.

7. Press the SRC-MAX PULSE RATE selection button. The SRC-MAX PULSE RATE 60 LED lights. The oximeter registers the pulse rate decreases and stabilizes at a value between 57 and 63 inclusive.

Figure 100. PLETH Display with SRC-MAX decrease to 60 BPM with high light condition

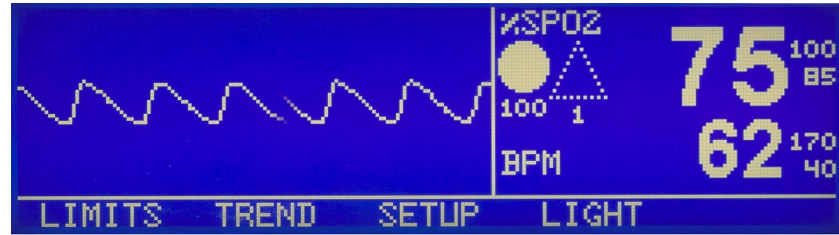

POX_10169_A

- a. Active audio alarm.
 - b. Flashing %SpO₂ indication between 73 and 77 inclusive.
 - c. BPM indication between 57 and 63 inclusive.
 - d. Pulse waveform of approximately 1/2-inch P-T-P amplitude. Actual amplitude may vary, but can be used as a reference for low modulation/high light indications.
8. Press the SRC-MAX %SpO₂ selection button. The SRC-MAX %SpO₂ 90 LED lights. The oximeter displays three dashes [- - -] and stabilizes at a value between 88 and 92 inclusive.

Figure 101. PLETH Display with SRC-MAX increase in %SpO₂ of 90 with high light condition



POX_10170_A

- a. No audio alarm.
- b. %SpO₂ indication between 88 and 92 inclusive.
- c. BPM indication between 57 and 63 inclusive.
- d. Pulse waveform of approximately 1/2-inch P-T-P amplitude. Actual amplitude may vary, but can be used as a reference for low modulation/high light indications.

%SpO₂

9. Press the SRC-MAX %SpO₂ selection button. The SRC-MAX %SpO₂ 75 LED lights. The oximeter displays three dashes [- - -] and stabilizes at a value between 73 and 77 inclusive.

Figure 102. PLETH Display with SRC-MAX decrease in %SpO₂ of 75 with high light condition



POX_10171_A

- a. Active audio alarm.
- b. Flashing %SpO₂ indication between 73 and 77 inclusive.
- c. BPM indication between 57 and 63 inclusive.
- d. Pulse waveform of approximately 1/2-inch P-T-P amplitude. Actual amplitude may vary, but can be used as a reference for low modulation/high light indications.

MOD

10. Press the SRC-MAX MODULATION selection button. The SRC-MAX MODULATION LED lights. The oximeter pulse amplitude waveform increases in amplitude.

Figure 103. PLETH Display with SRC-MAX increase in modulation with high light condition

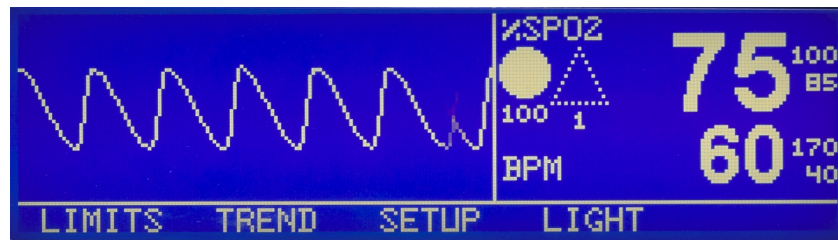

POX_10172_A

- a. Active audio alarm.
 - b. Flashing %SpO₂ indication between 73 and 77 inclusive.
 - c. BPM indication between 57 and 63 inclusive.
 - d. Pulse waveform of approximately 1-inch P-T-P amplitude. Actual amplitude may vary, but can be used as a reference for high modulation/high light indications.
11. Turn off the oximeter.

Setting Nurse Call

Figure 104. Data Port Connector



To set the nurse call setting:

1. Connect the negative lead of a voltmeter to pin 5 and positive lead to pin 11 of the Data Port Connector on the back of the oximeter.
2. Ensure the audible alarm is not turned off.
3. Connect the SRC-MAX tester to the DOC-10 pulse oximetry cable.
4. Connect the DOC-10 cable to the oximeter SpO₂ Sensor Port.
5. Turn on the oximeter and wait for the POST process to complete.



Note:

The oximeter should indicate a %SpO₂ alarm of 75.

6. Verify an output voltage at pins 5 and 11 between +5 to +12 VDC.
7. Press the ALARM SILENCE button. With the audible alarm silenced, the output voltage at pins 5 and 11 must be between -5 to -12 VDC, verifying the RS-232 Nurse Call function by simulating an alarm condition.
8. With oximeter in an alarm condition, use a digital voltmeter (DVM) to ensure there is no continuity (1 megohms or greater) between pins 8 and 15 and there is continuity (60 ohms or less) between pins 7 and 15.
9. Press the SRC-MAX tester %SpO₂ button to change the %SpO₂ to 90.
10. Use a DVM to verify there is continuity between pins 8 and 15 and that there is no continuity between pins 7 and 15, verifying the solid state Nurse Call function.

%SpO₂

Service Function Menus

Service functions can be used to select institutional defaults and to access information about the patient or oximeter. Only a trained Nellcor Customer Service Technician, qualified service technician, or clinical engineer should access many of the items available through the service functions.

Accessing Service Function Menus



WARNING

Audible alarms should not be silenced if patient safety could be compromised.

All service function menus are accessible when the DOC-10 pulse oximetry cable is disconnected from the oximeter. Disconnect the DOC-10 pulse oximetry cable from the oximeter or disconnect the OxiMax pulse oximetry sensor from the DOC-10 pulse oximetry cable.



Note:

Service function menus are only accessible from the Main Menu display.



Note:

With the DOC-10 pulse oximetry cable connected, only the PARAM and EXIT softkeys appear on the screen.

To access service function menus:

1. Turn on the oximeter by pressing the ON/STANDBY button.
2. Wait for oximeter power-on self-test to complete.
3. Simultaneously press and hold the LIGHT softkey and the HELP/CONTRAST button until the service softkeys display.

Navigational Softkeys

1. **SELECT Softkey**—SELECT the desired function.
2. **NEXT Softkey**—Access additional options for the Service Functions Menu by pressing the NEXT softkey.
3. **BACK Option**—Return back to the SERVICE Main Menu.
4. **EXIT Option**—Exit the Service Menu to the Main Menu.

Main Service Menu

The following list can be used as a quick reference showing how to reach different softkey functions. Items reached through the PARAM softkey can be accessed during normal operation. Functions provided by the PRINT and NEXT softkeys cannot be accessed when a pulse oximetry sensor is connected to the OxiMax N-600x pulse oximeter. The Service Menu softkey options provide access to several submenus.

Figure 105. PARAM and PRINT Service Menu

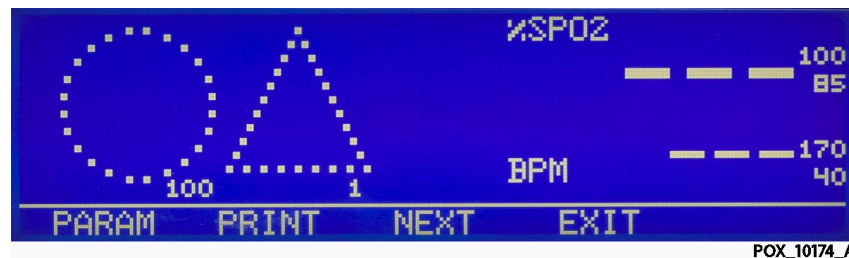

1. **PARAM Menu**—Reset and save parameters to factory defaults. Enable or disable patient alarm events.
2. **PRINT Menu**—Print trend data recorded for up to 45 hours. Access a list of all error log data recorded to memory. Retrieve or delete current trend data via an Instat printout.

3. **NEXT Menu**—Access the Download, Alarms, and Battery submenus.

PARAM (Parameters) Softkey Menu

By pressing the PARAM softkey, the softkey menu options change. These options can be accessed when a pulse oximetry cable is connected to the oximeter.

Figure 106. PARAM Service Menu Options

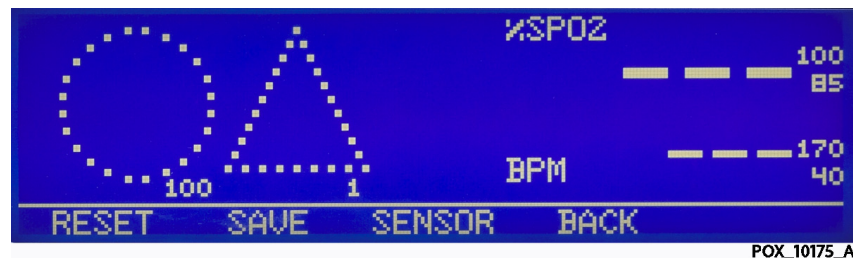

1. **RESET Softkey**—Use the RESET softkey if any settings stored in memory have been changed from factory default values. Pressing YES sounds three tones and returns the settings to factory default values. Pressing NO stores the oximeter settings into memory.
2. **SAVE Softkey**—When adjustable values are changed from factory default, use the SAVE softkey to preserve the settings as institutional power-on default values. Pressing YES stores the current settings in memory. The oximeter sounds three tones indicating that the changes have been saved as power-on default values. The new saved values continue to be used through power-on and off cycles until they are changed and saved again, or until they are reset. Pressing NO restores the original default values.



Note:

An invalid tone indicates a parameter value cannot be saved as a power-on default. See *Power-On Defaults and Alarm Ranges*, page 107. Along with the invalid tone, a message displays indicating which parameter could not be saved as a power-on default.

3. **SENSOR Softkey**—The SENSOR softkey is only available if a data-capable sensor is attached. The SENSOR softkey enables/disables the Sensor Event Record function. Enabling this feature makes the sensor the primary resource for trend data on a particular sensor. Disabling this feature makes the oximeter the primary resource for trend data, regardless of which sensor is used.

PRINT Softkey Menu

Pressing the PRINT softkey provides options for TREND, ERRLOG, INSTAT, and INFO printouts. Select the appropriate printout with the corresponding softkey.

Up to 45 hours of trend data can be viewed on the printouts described below. When the oximeter is turned on, trend data is recorded every second. As an example, an

oximeter that is used six hours a week takes approximately eight weeks to fill the memory.

Figure 107. PRINT Service Menu Options



POX_10177_A

1. **TREND Softkey**—A Trend printout includes all data recorded for up to 45 hours of monitoring since the last Delete Trends was performed. A new trend point is recorded every second. At the end of the printout “Output Complete” prints indicating the data is not corrupt. If the Output Complete statement does not print at the end of the printout, consider the data invalid.
2. **ERRLOG Softkey**—Used only by Nellcor’s Customer Service Engineering, a qualified service technician, or a clinical engineer. Selecting the ERRLOG softkey provides a list of all the errors recorded in memory. The first line lists the type of oximeter producing the printout, software level, type of printout, and the time of the printout. The second line of the printout consists of column headings. If nothing prints out, there have been no errors. At the end of the printout “Output Complete” prints indicating the data is not corrupt. If the Output Complete statement does not print at the end of the printout, consider the data invalid.
3. **INSTAT Softkey**—Used by Nellcor’s Customer Service Engineering, a qualified service technician, or a clinical engineer. In the INSTAT printout, line one is for oximeter type, software revision level, type of printout, and alarm parameter settings. The second line contains the column headings. A trend point is recorded for every four seconds of oximeter operation. Up to 45 hours of oximeter operation data can be recorded. If the final line on the printout shows “Output Complete,” then the data has been successfully transmitted with no corruption. If there is no “Output Complete” line printed, the data should be considered invalid.
4. **INFO Softkey**—Used by Nellcor’s Customer Service Engineering, a qualified service technician, or a clinical engineer. Pressing the INFO softkey produces a single line printout of oximeter information. The data presented in the printout from left to right, is the oximeter type (N-600x), software version level, type of printout (INFO), CRC (Cyclic Redundancy Check) number, and ratio of current operating time to total operating time (the ratio itself has no units of measure).
5. **DELETE Softkey**—Deletes the most recent trend data. The current trend data, along with the deleted trends, can be retrieved from the oximeter through an Instat printout. The oldest deleted trend is Trend 01 on the Instat printout. If a Trend 01 already exists in memory from an earlier Delete, the next deleted trend will become Trend 02. Each time DELETE is pressed, the number of existing trends increases by 1. The current trend has the largest trend number.

NEXT Softkey Submenus

Figure 108. DOWNLD and ALARMS Service Menu Options



POX_10176_A

1. **DOWNLD Softkey**—Used to display the revision of the Boot Code. To exit DOWNLD, cycle power to the oximeter by pressing the ON/STANDBY button. Consult the Directions for Use (DFU) provided with any downloads or upgrades to the FLASH firmware. The baud rate for downloading new software is 19200 via the data port.
2. **ALARMS Softkey**—Changes characteristics of the audible alarm. Allows caregivers to turn off alarms by selecting YES or disallows the ability to turn off alarms by selecting NO. Use a reminder to warn caregivers the alarm is off by enabling this feature, or choose to disable the reminder. Enable or disable a SatSeconds reminder. Press BACK to return to the Service Menu.



WARNING

Audible alarms should not be silenced if patient safety could be compromised.

Figure 109. ALARMS Service Menu Options



POX_10179_A

To change audible alarm status:

- a. Disconnect the OxiMax pulse oximetry sensor from the oximeter.



Note:

If the OxiMax pulse oximetry sensor is connected, the only softkeys on the oximeter's screen display are PARAM and EXIT.

- b. Simultaneously press the LIGHT softkey and the HELP/CONTRAST button until the menu bar changes to the softkey headings shown below.
- c. Press the NEXT softkey.
- d. Press the ALARMS softkey.
- e. Use the SELECT softkey to toggle between ALLOW OFF, OFF REMINDER, or ALLOW SAT-S options. Use the ADJUST UP or ADJUST DOWN button to change selected parameter.

- f. Use the SELECT softkey to toggle between ALLOW OFF, OFF REMINDER, or ALLOW SAT-S options. Use the ADJUST UP or ADJUST DOWN button to change selected parameter.
- **ALLOW OFF**—Enable or disable the AUDIBLE ALARM OFF option. Press the ADJUST UP or ADJUST DOWN button to toggle between YES and NO. If YES is selected, the option of selecting AUDIBLE ALARM OFF as an alarm silence duration choice becomes available. If NO is selected, no additional option becomes available.
 - **OFF REMINDER**—Enable or disable the reminder tone for when the alarm off option has been used. If the audible alarm is set to OFF, a reminder tone can be sounded every three minutes to notify the user of this condition. The ADJUST UP and ADJUST DOWN buttons can be used to change the choice from YES to NO. Selecting YES enables the Reminder. Selecting NO disables the Reminder when the audible alarm is set to OFF.
 - **SPD Setup**—This option is only available after activation of the SPD feature by a qualified service technician. Enable or disable the ALLOW SPD option and select from the AUDIO ALERT options. Use the ALLOW SPD option to enable or disable OxiMax SPD™ Alert saturation pattern detection. If SPD is enabled, the SPD feature is available for adults in clinical settings and also automatically enables Sat-Seconds, setting the Sat-Second value at 100. Use the AUDIO ALERT option to select AUD VIS for both audio and visual SPD alarms (tonal alarm and flashing TREND key), or to select VIS for visual only SPD alarms (flashing TREND key only).

Figure 110. SPD Service Menu Options



POX_10181_A

- g. Press the BACK softkey.

3. **BATTERY Option**—Reserved for Nellcor use only. Do not use.

Figure 111. BATTERY Service Menu Options



POX_10178_A



12 Troubleshooting

Overview

This section describes how to troubleshoot common problems while using the OxiMax N-600x™ pulse oximeter. This section also includes information about the on-screen help function, error code messages, and how to obtain technical help and support.



WARNING

If you are uncertain about the accuracy of any measurement, check the patient's vital signs by alternate means; then make sure the pulse oximeter is functioning correctly.



WARNING

Only qualified service personnel should open the oximeter housing, remove and replace components, or make adjustments. If your medical facility does not have a qualified service technician, please contact Nellcor's Technical Services or your local Nellcor representative.



WARNING

Do not spray, pour, or spill any liquid on the OxiMax N-600x pulse oximeter, its accessories, connectors, switches, or openings in the chassis.

Help and Support

Technical Services

If you experience a problem while using the OxiMax N-600x pulse oximeter and are unable to correct it, contact Nellcor's Technical Services Department at 1.800.635.5267, or your local Nellcor representative. The *N-600x Service Manual*, used by qualified service personnel, provides additional troubleshooting information.

The *N-600x Service Manual* is available on the Internet at:

<http://www.nellcor.com/serv/manuals.aspx/>

On-Screen Help

The oximeter is equipped with an on-screen help system which enables you to browse and navigate through multiple help topics. Follow the steps outlined below to access and utilize the on-screen help.

To access on-screen help topics

Access multiple on-screen help topics and select a specific topic to view. Follow the example described below to access the SatSeconds help topic.

1. From the Main menu, press the HELP/CONTRAST key. The HELP MAIN window appears.

Figure 112. First Main Menu Help Screen



POX_10105_A

2. Press the ADJUST UP or ADJUST DOWN key to scroll through the available help topics or press NEXT to access page (2 / 2). Page (2 / 2) of the HELP MAIN window appears.

Figure 113. Second Main Menu Help Screen



POX_10173_A

3. From page (2 / 2) of the HELP MAIN window, press ADJUST DOWN to select SPD and then press SHOW. The HELP SPD window appears. The Saturation Pattern Detection (SPD) help topic contains a total of ten (10) consecutive help windows. Press the NEXT softkey to scroll through each window of the selected help topic for the following information:

“Saturation Pattern Detection detects repetitive patterns of desaturation in the trend in adults. Caregivers are alerted to these patterns via a visual indicator, and optionally, an audio alarm. The triangle icon for Saturation Pattern Detection appears on the monitor display when the feature is enabled. The triangle fills from the bottom to the top as patterns become more severe and empties from top to bottom as the patterns become less severe. If the triangle fills, an alarm sounds. With Saturation Pattern Detection enabled, the default setting is On with the sensitivity set to 1. The feature can be turned off in the LIMITS menu. Caregivers can select from three alarm sensitivity settings: 1 (most sensitive), 2 (medium sensitivity) or 3 (least sensitive), with 1 resulting in more alarms and 3 resulting in fewer alarms.

Enabling Saturation Pattern Detection automatically activates the SatSeconds feature.

The TREND key blinks when a Saturation Pattern Detection alarm occurs. If the alarm is resolved, the TREND key stops blinking but remains highlighted until the caregiver presses it to view the event or clears it by pressing the TREND key.”

- From page (2 / 2) of the HELP MAIN window, press ADJUST DOWN to select PRDELAY and then press SHOW. The HELP PRDELAY window appears. The SatSeconds help topic contains a total of two (2) consecutive help windows. Press the NEXT softkey to scroll through each window of the selected help topic for the following information:

“Pulse Rate Alarm Delay can reduce alarms reported for brief pulse rate limit violations. The Pulse Rate Alarm Delay can be set to 5 or 10 seconds, or OFF.”

- From page (2 / 2) of the HELP MAIN window, press ADJUST DOWN to select SATSECONDS and then press SHOW. The HELP SATSECONDS window appears. The SatSeconds help topic contains a total of six (6) consecutive help windows. Press the NEXT softkey to scroll through each window of the selected help topic for the following information:

“SatSeconds can reduce alarms reported for mild or brief SpO2 limit violations. Each SpO2 violation can be described as a product of magnitude (number of percentage points of the SpO2 value falls outside the limit) and time (the number of seconds the SpO2 the value remains outside the limit). The SatSeconds limit sets the minimum value the SatSeconds must reach before an alarm is reported. For example: if the SpO2 lower alarm limit is 90 and the measured SpO2 value is 88, the resulting value is 2 after one second, 4 after two seconds, and so on. If the SatSeconds limit is set to 10, an alarm is reported after five seconds. To adjust the SatSeconds limit, press LIMITS.”

- Press the BACK softkey at any juncture to review the previous window(s). Continue to press BACK to return to the HELP MAIN window.
- Press EXIT to return to the oximeter’s Main menu.

To access a single help topic

Access single on-screen help topics by pressing the HELP/CONTRAST softkey from a submenu. As an example, this procedure provides direction for accessing help information on the SatSeconds feature.

- Press LIMITS on the oximeter Main menu and then SELECT to highlight SAT-S (SatSeconds).
- Press the HELP/CONTRAST softkey. The HELP LIMITS window appears.

Figure 114. Limits Help Screen Main Menu

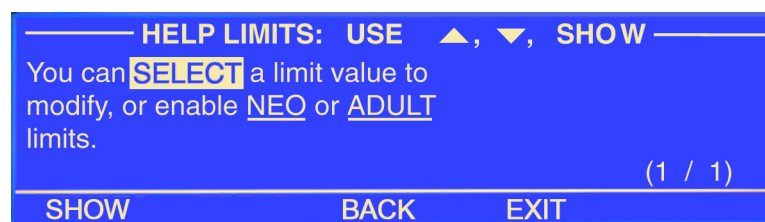

POX_10107_A

- Press ADJUST UP or ADJUST DOWN to highlight an available help topic (SELECT, NEO and ADULT). For this example, highlight SELECT.

- Press SHOW. The HELP LIMITS SELECT window appears.

Figure 115. Select Limits Help Screen



POX_10108_A

- Press BACK.
- Press ADJUST DOWN t to highlight NEO and then press SHOW. The HELP LIMITS NEO window appears.

Figure 116. Neonate Limits Help Screen

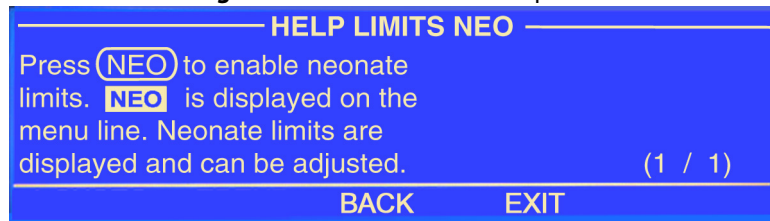

POX_10109_A

- Press BACK.
- Press ADJUST DOWN t to highlight ADULT and the press SHOW. The HELP LIMITS ADULT window appears.

Figure 117. Adult Limits Help Screen

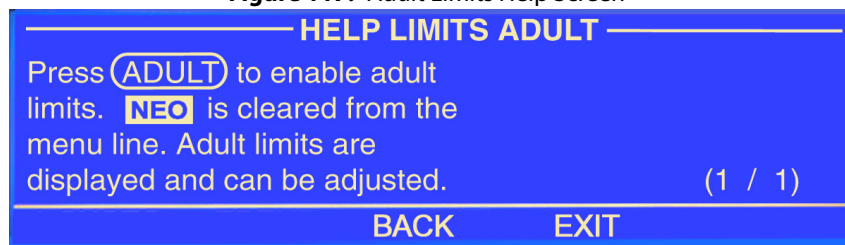

POX_10110_A

- Press EXIT to return to the LIMITS display.

Problem Resolution

If a problem occurs with the OxiMax N-600x pulse oximeter, take the appropriate corrective action. The following broad problem categories cover the majority of the

symptoms an oximeter might display. Refer to the listed section for corrective actions.

Table 23. Problem Categories

Symptom	Recommended Corrective Action
Power No power using AC and/or DC power source. Fails power-on self-test. Powers down without apparent cause.	See <i>Power</i> , page 152.
Keys Oximeter does not respond proerly to pressed keys.	See <i>Keys</i> , page 153.
Display/Alarms Display does not respond properly. Alarms and other tones do not sound properly or sound without apparent cause.	See <i>Display/Alarms</i> , page 153.
Operational Performance Display appears to be operational, but shows no readings. Suspect readings.	See <i>Operational Performance</i> , page 154.
Data Port Oximeter data port not functioning properly.	See <i>Data Port</i> , page 154.

Prompts, Error Messages, and Error Codes

Prompts and Error Messages

Occasionally, the menu area displays a prompt or error message. In most instances, messages remain displayed for a set time. This depends on the criticality of the message. High priority messages overwrite low priority messages. Messages of the same priority display in order of occurrence. For multiple messages, lower priority messages display when higher priority conditions clear. The highest priority is "1" and the lowest is "3." Messages remain on the screen until the condition clears if the time-out setting is NONE. If the message has a maximum time to remain on the screen, it will have a time-out setting.



Note:

Pressing the ALARM and/or ALARM SILENCE keys clears some messages. Pressing the ALARM SILENCE key silences any audible tone and the second press clears the message.

1. **Prompts**—Prompts require a response. For example, the “SAVE DEFAULTS?” prompt requires a user response of YES or NO.

Figure 118. Save Defaults Prompt Screen

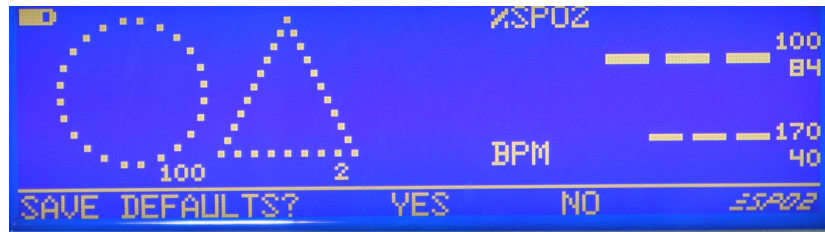

POX_10111_A

2. **Error messages**—Error messages provide information. The SENSOR DISCONNECTED error message leaves any action to the discretion of the user. Advisory messages appear as centered text at the bottom of the screen.

Figure 119. Sensor Disconnected Message Screen

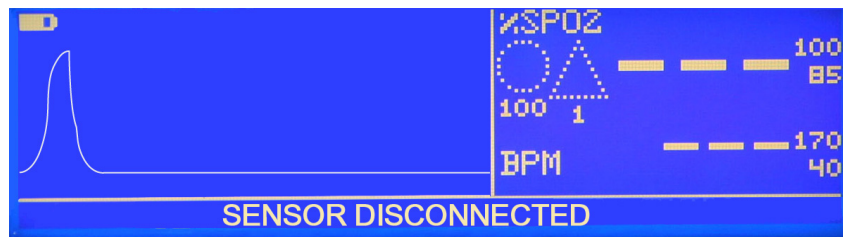

POX 10112 A

Table 24. Common Prompts and Error Messages

Message	Time-out in secs	Exit on Alarm?	Exit on Alarm Silence?	Displayed	Resolution
ADJUST CONTRAST UP/DOWN	10	Yes	Yes	When pressing and holding the HELP/ CONTRAST key.	To adjust the contrast, use the ADJUST UP to increase the contrast or ADJUST DOWN key to decrease contrast.
CLOCK SETTING LOST	None	No	No	If the oximeter detects that the real-time clock has stopped running and both battery and AC power are lost.	Power-cycle the oximeter. If the error remains, recharge or replace the battery.
DATA IN SENSOR	5	No	Yes	When a sensor containing data is connected to the oximeter.	Clears on time-out, sensor disconnect, or pressing the ALARM SILENCE key, whichever comes first.
DATA TYPE: SpO2	5	No	Yes	When a blank event sensor is connected to oximeter with the event data type set to SpO2.	Clears on time-out, sensor disconnect, or pressing the ALARM SILENCE key, whichever comes first.

Table 24. Common Prompts and Error Messages

Message	Time-out in secs	Exit on Alarm?	Exit on Alarm Silence?	Displayed	Resolution
DATA TYPE SpO2+BPM	5	No	Yes	When a blank event sensor is connected to a oximeter with event data type set to SpO2+BPM.	Clears on time-out, sensor disconnect, or pressing the ALARM SILENCE key, whichever comes first.
DEFAULTS LOST	None	No	No	If the oximeter detects that power-on settings have been lost.	Leave the factory default settings, have a qualified service technician change institutional defaults, or change temporary limit settings.
DELETE TRENDS?	10	Yes	Yes	When attempting to delete trend data from memory by pressing the DELETE softkey.	Respond to the prompt, electing to delete trends by selecting YES or to retain by selecting NO.
HELP SPEAKER FAILURE	None	No	No	After pressing the HELP softkey provided after a Primary Speaker Failure	Notify a qualified service technician. Once the oximeter powers down, it will not power on again until the technician replaces the failing speaker.
INVALID SILENCE DURATION	3	No	Yes	When attempting to save current settings as power-on defaults, even though the ALARM SILENCE duration is OFF.	If attempting to save defaults, turn ALARM SILENCE duration to a value, rather than OFF.
INVALID %SpO2 LIMIT	3	No	Yes	After attempting to set the default %SpO2 lower alarm limit below 85.	Set power-on %SpO2 lower alarm limit default at or above 85.
LOW BATTERY	None	No	Yes	When the oximeter is on battery power and the battery charge is low.	Connect to AC power to fully charge or temporarily acknowledge by pressing the ALARM SILENCE key.
PRIMARY SPEAKER FAILURE	None	No	No	Fatal error caused by a hardware failure. Once this error displays, the only option available is to press the HELP softkey, which produces the HELP SPEAKER FAILURE message.	Press the HELP softkey to review the HELP SPEAKER FAILURE message. Notify a qualified service technician. Once the oximeter powers down, it will not power on again until the technician replaces the failing speaker.

Table 24. Common Prompts and Error Messages

Message	Time-out in secs	Exit on Alarm?	Exit on Alarm Silence?	Displayed	Resolution
READING TRENDS...	None	Yes	Yes	When the oximeter needs more than four to six seconds to retrieve trend data from memory.	Completely retrieve sensor data or select ABORT.
REPLACE SENSOR	None	No	Yes	When the sensor or cable wiring is defective.	Temporarily acknowledge by pressing the ALARM SILENCE key. Replace sensor.
RESET DEFAULTS?	10	No	Yes	When attempting to reset oximeter to factory default setting by pressing the RESET softkey on the PARAMS menu.	Leave default settings as they are by selecting NO, or revert back to the original factory default settings by selecting YES.
SAVE DEFAULTS?	10	No	Yes	When attempting to save current settings as power-on defaults by pressing SAVE in the PARAMS menu.	Confirm the new institutional default settings by selecting YES, or leave default settings as they are by selecting NO,
SENSOR DISCONNECTED	None	No	Yes	When the sensor is disconnected from the pulse oximetry cable, the cable is not connected to the oximeter, or the cable wiring is defective.	Temporarily acknowledge by pressing the ALARM SILENCE key. Connect the cable and sensor to the oximeter, reconnect the sensor, or check all connections. If this does not clear the condition, replace the cable and/or sensor.
SENSOR TYPE	5	No	No	First message displayed when a sensor is connected to the oximeter.	Automatically clears on time-out.

Error Codes

When the OxiMax N-600x pulse oximeter detects an error condition, it displays “EEE” followed by an error code of up to three digits.

Figure 120. Error Condition Screen, Battery Failure



When an error code other than the ones listed in Table Table 25 on page 145 appears, turn the oximeter off and back on again. Cycling the power should clear the error. If the error code reappears, record it and notify service personnel. When this occurs, the unit will stop monitoring, remove all information from the screen and display the message “EEE XXX,” and sound a low priority alarm. See *Error Codes for Non-correctable Failures*, page 146.

Table 25. EEE Error Codes

Error Code	Error Message	Corrective Action
80	DEFAULTS LOST	The current power-on default settings have been lost and returned to factory defaults. Qualified service personnel can use the <i>N-600x Service Manual</i> to restore the desired power-on default settings.
81	SETTINGS LOST	The current settings (for example, alarm limits, alarm and pulse beep volumes, alarm silence duration) have been lost and returned to power-on defaults. Turn the oximeter off and back on again. If it is necessary to have settings different from the power-on default settings, turn the oximeter off and back on again, and reenter the desired settings.
82	CLOCK SETTING LOST	Date and time settings are lost. Reenter the date and time. Recharge or replace the battery.
515, 518, 534, 535, 569	N-600x Boot Version x.x.x.x	The application software is missing or corrupt. Notify a qualified service technician.
529, 729	LOW BATTERY	The battery is discharged to a critically low level. The oximeter will shutdown after 10 seconds. Verify the SUPPLY VOLTAGE SELECTOR switch on the rear panel is set to the proper voltage. Connect the oximeter to AC power and turn back on. A warning message is displayed and a low priority audible alarm sounded. Press the ALARM SILENCE key twice before the oximeter can be used for patient monitoring.
575	TRENDS LOST	Oximeter trends are corrupted and will be cleared. Turn off the oximeter, and then back on again.
701-716, 720-724, 732-740, 576-582	POWER SUPPLY FAILURE	The oximeter power supply has detected an error. The oximeter will shutdown after 10 seconds. Verify the oximeter is operating within specified environmental conditions. Notify a qualified service technician.
717, 718	BATTERY FAILURE	The oximeter has detected a battery open or short condition. The oximeter will shutdown after 10 seconds. Battery should be replaced. Notify a qualified service technician.
725-728, 730	REPLACE BATTERY	The battery is not charging properly. The oximeter will shutdown after 10 seconds. Battery should be replaced. Notify a qualified service technician.

Error Codes for Non-correctable Failures

Contact Nellcor’s Technical Services Department, or your local Nellcor representative should the oximeter detect a non-correctable failure. When one of the listed errors occurs, several events also occur.

- The oximeter sounds a low priority alarm that cannot be silenced except by power cycling the oximeter.
- Measurements stop.
- All information on the screen vanishes, displaying an error code message. Error code messages begin with EEE and are followed by an error code.



Note:

Cycling the power may clear the displayed error code.

Table 26. Error Code Listing for Non-correctable Failures

Error Code	Category	Description	
1	%SpO2 front end	%SpO2 front end RAM error.	
2		%SpO2 front end ROM/code integrity error.	
3		%SpO2 front end reported a bad Cyclic Redundancy Check (CRC).	
4		%SpO2 front end reported FSP message not allowed.	
5		%SpO2 front end reported illegal value sent in FSP message %SpO2 front end.	
6		%SpO2 front end reports calibration (offset) failure.	
9		%SpO2 front end reported syntax error in FSP message.	
10		Over-current limit in %SpO2 front end has tripped.	
11		%SpO2 front end reports incorrect system voltage.	
12		%SpO2 front end reports other hardware problem.	
14		%SpO2 front end reports communication channel overflow.	
16		%SpO2 front end reports watch dog time out.	
17		%SpO2 front end	%SpO2 front end reports that sensor appears defective.
18			%SpO2 front end reports internal register appears modified from expected value.
19	%SpO2 front end reports signal out-of-range.		
48	%SpO2 front end reports spurious interrupt.		
49	%SpO2 front end reports internal buffer overflow.		
50	%SpO2 front end reports intermittent error.		
51	%SpO2 front end reports digital communications error.		
52	%SpO2 front end reports warmer error.		
53		Front end data not received.	

Table 26. Error Code Listing for Non-correctable Failures

Error Code	Category	Description
54-128		Reserved for future front end object errors.
129-171	LPS	Unexpected LPS error (LPS recovered from this error).
172-255		Reserved for future back end object errors.
256	%SpO2 back end	%SpO2 back end reports beginning of packet missing.
257		%SpO2 back end reports packet start ID (SID) missing.
258		%SpO2 back end reports packet length error.
259		%SpO2 back end reports message length error.
260		%SpO2 back end reports packet contains unsupported key.
261		%SpO2 back end reports packet CRC error.
262		% back end reports end of packet missing.
263		%SpO2 back end reports packet contains undefined key.
264		%SpO2 back end reports corrupted variable.
265		%SpO2 back end reports memory overflow.
266		%SpO2 back end reports bad pointer.
267		%SpO2 back end reports parameter value out-of-range.
268		%SpO2 back end reports reset detected.
269		%SpO2 back end reports unexpected value.
270		%SpO2 back end reports time-out.
271		%SpO2 back end reports not ready/not initialized.
272		%SpO2 back end reports double fault.
273		%SpO2 back end reports date out-of-range error.
274		%SpO2 back end reports incompatible software version.
275		%SpO2 back end reports incorrect registration number.
276	%SpO2 back end	%SpO2 back end reports sensor read failure.
277		%SpO2 back end reports sensor signature verification fails.
278		%SpO2 back end reports warmed sensor temperature set point failure.
279		%SpO2 back end reports warmed sensor /%SpO2 front end incompatible.
280		%SpO2 back end reports does not support feature required by sensor.
281		%SpO2 back end reports overflow/underflow.
282		%SpO2 back end reports sensor activation failure.
283		%SpO2 back end reports sensor write failure.
284		ECG trigger error.

Table 26. Error Code Listing for Non-correctable Failures

Error Code	Category	Description
285	Sensor trend	Sensor trend not open.
286		Sensor trend already open.
287		Sensor trend data unavailable.
288		All sensor trend data read.
289		Incompatible private label.
290-511		Reserved for future back end object errors.
512	UIF	General failure of UIF Module generic post.
512	Battery	Dead battery/Missing battery.
514		Real time clock is non-operational.
515		Application code is not present in the Flash.
516		Invalid Flash type.
517		Serial clock line is not toggling or is toggling at an incorrect rate.
518		Application program is corrupt.
519		Invalid Nell-1A version.
520		Error in the start up sequence.
521		OS multi-tasking service failure.
522		A state machine has received an unknown state transition.
523		The operation just attempted was not completed successfully - for example, Institutional Defaults could not be reset.
524		An unexpected value was received - for example, an out-of-range parameter was passed to a function.
525	CRC	EEPROM CRC failure.
526		%SpO2 module not responded.
527	CRC	Institutional parameters lost - e.g. for UIF: Institutional EEPROM section CRC corrupt.
528		Current settings lost - e.g. for UIF: Institutional EEPROM section CRC corrupt.
529	Battery	Critical low battery.
530		Low battery error.
531		External watchdog failure.
532		Power PC watchdog failure.
533		Boot NVROM un-initialized error.
534	CRC	Failed CRC check of application code in flash.
535		Failed periodic ram CRC check on application code running in RAM.

Table 26. Error Code Listing for Non-correctable Failures

Error Code	Category	Description
560		Memory corruption detected.
561		RTOS Resource unavailable.
562	%SpO2 front end	%SpO2 front end reset.
563		%SpO2 reported error.
564		Clinical mode was exited after input was received.
565	Comm	Communication failures between software modules.
566	UIF	Excessive resets before UIF runs.
567		An unexpected interrupt has been asserted.
568		General failure in UIF module generic post.
569		BOOT application program is corrupt - CRC does not match.
570		RTC was restarted.
574		Excessive restarts within one minute.
575	Trend data	Trend data corrupted
576	LPS	Logic Processing Board (LPS) is going through excessive resets.
577		LPS status messages not arriving in a timely manner.
578		LPS driver has received too many corrupt (protocol error) messages.
579		Status report AC OK bit does not equal the hardware AC OK signal.
580		LPS driver received only a partial LPS message.
581		Too many corrupt (invalid data) message.
582		Unable to enter shelf-mode, this could mean that the LPS is dead or there is a serial port transmit problem.
583	Speaker	Primary speaker failure detected.
650	Module	Oximetry module reports internal software consistency check failed.
651		Oximetry module reports software functions executed before initialization completed.

Table 26. Error Code Listing for Non-correctable Failures

Error Code	Category	Description	
652	Module	Oximetry module reports internal memory buffer overflow.	
653		Oximetry module reports host reset.	
654		Oximetry module ROM/Code integrity error.	
655		Oximetry module RAM error.	
656		Oximetry module reports background self-test failed to complete in the allocated time.	
657		Oximetry module reports a state machine is in an unexpected state.	
658		Oximetry module reports memory corruption detected.	
659		Oximetry module reports spurious interrupt detected.	
660		Oximetry module reports unable to issue commands to %SpO2 front end.	
661		Oximetry module reports unable to write to external Flash.	
662		Oximetry module reports communication with %SpO2 front end lost.	
663		Oximetry module reports internal register modified from expected value.	
701		POST	POST external hardware failsafe circuit error.
702			POST PWR_ENA fail.
703	Unknown state machine # or charge state.		
704	Unexpected interrupt.		
705	Stack over/under error.		
706	ROM CRC error - POST or background.		
707	POST RAM error.		
708	Unexpected reset.		
709	Unexpected internal WD instance #1.		
710	Unexpected internal WD instance #2.		
711	Unexpected internal WD instance #3.		
712	Unexpected internal WD instance #4.		
713	Unexpected internal WD instance #5.		
714	Unexpected internal WD instance #6.		
715	LINE_V & AC_OK disagree.		
716	POST Internal WD circuit error.		
717	Battery	Battery shorted with AC power.	
718		Battery open with AC power.	
719	EEPROM	EEPROM W/R failure - POST or background.	
720	Battery	Battery charger error - instance #1.	

Table 26. Error Code Listing for Non-correctable Failures

Error Code	Category	Description
721	Battery	Battery charger error - instance #2.
722		Battery charger error - instance #3.
723		Battery charger error - instance #4.
724		Battery charger error - instance #5.
725		Battery charger error - instance #6.
726		Battery charger error - instance #7.
727		Battery charger error - instance #8.
728		Battery charger error - instance #9.
729		Battery critical without AC power.
730		Battery fail without AC power.
731		EEPROM
732	Vref	Vref error on DC.
733		Vref error on AC.
734	Temp	Overtemperature (> 58 C).
735	Battery	Battery I charge.
736		Battery I discharge.
737	Temp	Temperature low.
738	Failsafe	Hardware failsafe occurred, maybe overtemperature.
739		Hardware failsafe occurred, maybe overcurrent.
740		Hardware failsafe occurred, cause unknown.
741	Battery	Message RX CRC error.
743	Shutdown	Error in the shut down sequence. Occurs if the power is cycled off and on too quickly.

Power

Power problems are related to AC and/or DC power issues. Use the following recommended actions to correct power problems.

Table 27. Power Problems

Symptom	Recommended Corrective Action
<p>Low Battery indicator lights steadily while oximeter is connected to AC and the battery is not discharged.</p>	<ul style="list-style-type: none"> • Ensure the oximeter is plugged into an operational AC outlet and the AC indicator is lit. • Check the external fuses. The fuses are located in the Power Entry Module as indicated in <i>Fuse Replacement</i>, page 166. Replace if necessary. • Open the oximeter as described in <i>Disassembling the Oximeter</i>, page 167. Check the internal battery fuse F3 and replace if necessary. • If the oximeter is still experiencing power problems, install a new battery and verify the charging voltage output to the battery while on AC power when first turning on the oximeter. The charging voltage increases to 7.05 - 7.35 volts if the battery is good. The charging voltage decreases over time. Replace the power supply if the above charging values are not met. See <i>Replacing the Power Supply</i>, page 175. • Check the harness connection from the bottom enclosure to the Main Board PCB, as instructed in <i>Main Board PCB Replacement</i>, page 179. If the connection is good, replace the Main Board PCB.
<p>The oximeter generates an error code when disconnected from AC power, and the oximeter is powered up.</p>	<ul style="list-style-type: none"> • The battery may be discharged. To recharge the battery, refer to <i>Using Battery Power</i>, page 51. The oximeter may be used with a less than fully charged battery but with a corresponding decrease in operating time from that charge. The battery may be defective.
<p>Low Battery indicator on during DC operation and an alarm is sounding.</p>	<ul style="list-style-type: none"> • There are less than 15 minutes remaining of usable charge left on the battery before the oximeter shuts off. If possible, cease using battery power. Connect the oximeter to an AC source and allow it to recharge. A full recharger takes approximately eight hours. If continuing to use the oximeter as it recharges, a full battery recharge takes 12 hours.
<p>Battery does not charge.</p>	<ul style="list-style-type: none"> • Replace battery if it is more than two years old. • If the battery fails to hold a charge, replace the battery as indicated in <i>Battery Replacement</i>, page 170. • Open the oximeter as described in <i>Top Case Assembly Replacement</i>, page 183. Replace a new battery and verify the charging voltage output to the battery while on AC when first turning the oximeter ON. The charging voltage will climb between 7.05 to 7.35 volts. Since the battery is good, the charging voltage will decrease with time. Replace power supply if above values are not met.

Keys

This section relates to non-responsive keys.

Table 28. Keys Problems

Symptom	Recommended Corrective Action
Keys do not respond when the oximeter is turned on.	<ul style="list-style-type: none"> Replace the Main Board PCB. See <i>Main Board PCB Replacement</i>, page 179. If the keys still do not work, replace the Top enclosure assembly. See <i>Top Case Assembly Replacement</i>, page 183.

Display/Alarms

This section relates to non-functioning displays and audible tones or alarms.

Table 29. Display/Alarms Problems

Symptom	Recommended Corrective Action
Display values are missing or erratic.	<ul style="list-style-type: none"> If the OxiMax pulse oximetry sensor is connected, replace the pulse oximetry cable. If the condition continues, replace the OxiMax pulse oximetry sensor. If the condition persists, replace the Main Board printed circuit board. See <i>Main Board PCB Replacement</i>, page 179.
Display pixels do not light.	<ul style="list-style-type: none"> Check the connection between the Main Board PCB and the Display PCB. If the condition continues, replace the Display PCB. See <i>Display PCB Replacement</i>, page 177. If the condition persists, replace the Main Board PCB. See <i>Main Board PCB Replacement</i>, page 179.
Alarm sounds for no apparent reason.	<ul style="list-style-type: none"> Moisture or spilled liquids can cause an alarm to sound. Allow the oximeter to dry thoroughly before using. If the condition persists, replace the Main Board PCB. See <i>Main Board PCB Replacement</i>, page 179.
Alarm does not sound.	<ul style="list-style-type: none"> Check the alarm silence status. Check the speaker connection. Replace the speaker as described in <i>Alarm Speaker Replacement</i>, page 181. If the condition persists, replace the Main Board PCB. See <i>Main Board PCB Replacement</i>, page 179.
Primary speaker fails and a slow-pulsing, high-pitched tone sounds.	<ul style="list-style-type: none"> Press the HELP/CONTRAST button and follow the on-screen messages.

Operational Performance

This section relates to operational performance where no error codes display.

Table 30. Operational Performance Problems

Symptom	Recommended Corrective Action
The Pulse Amplitude indicator seems to indicate a pulse, but displays zeroes.	<ul style="list-style-type: none"> The OxiMax pulse oximetry sensor may be damaged; replace the sensor. If the condition persists, replace the Main Board PCB. See <i>Main Board PCB Replacement</i>, page 179.
%SpO2 or pulse values change rapidly; Pulse Amplitude indicator is erratic.	<ul style="list-style-type: none"> The OxiMax pulse oximetry sensor may be damp or may have been reused too many times. Replace the sensor. An electrosurgical unit (ESU) may be interfering with performance: <ul style="list-style-type: none"> Move the oximeter and its cables and OxiMax pulse oximetry sensors as far from the ESU as possible. Plug the oximeter power supply and the ESU into different AC circuits. Move the ESU ground pad as close to the surgical site as possible and as far away from the OxiMax pulse oximetry sensor as possible. Verify the performance with the procedures detailed in <i>Operating the Oximeter</i>, page 55. If the condition persists, replace the Main Board PCB. See <i>Main Board PCB Replacement</i>, page 179.

Data Port

This section relates to data port issues.

Table 31. Data Port Problems

Symptom	Recommended Corrective Action
No printout received.	<ul style="list-style-type: none"> Confirm the printer is working through an alternate means. The oximeter's baud rate does not match the printer. Change the baud rate of the oximeter following instructions in <i>Configuring the Data Port Interface</i>, page 84. If the condition persists, replace the Main Board PCB. See <i>Main Board PCB Replacement</i>, page 179.
The RS-232 nurse call is inoperable.	<ul style="list-style-type: none"> Verify the connections are made between pins 5 (GND) and 11 (nurse call) of the data port. See <i>Using the Nurse Call Interface</i>, page 93. Verify the output voltage between ground pin 5 and pin 11 is -5 to -12 VDC (no alarm) and +5 to +12 VDC (during alarm). See <i>Using the Nurse Call Interface</i>, page 93. If the condition persists, replace the Main Board PCB. See <i>Main Board PCB Replacement</i>, page 179.

Primary Speaker Failure



WARNING

If an OxiMax N-600x pulse oximeter reports a primary speaker failure, do not use the oximeter longer than necessary to ensure patient safety. Contact a qualified service technician, your local Nellcor representative, or Nellcor's Technical Services Department at 1.800.635.5267 for assistance.



Note:

Once the oximeter is silenced, the oximeter sounds a piezo tone every three minutes as a reminder of the primary speaker failure condition. The oximeter also sounds the piezo tone to annunciate low, medium and high priority alarms during this time. An OxiMax N-600x pulse oximeter powered off while reporting a primary speaker failure cannot be powered on again until repaired.

To access primary speaker failure messages

The OxiMax N-600x pulse oximeter may detect a failure of the primary speaker and sound a high-pitched, slow-pulsing piezo tone. A primary speaker failure message displays.

Figure 121. Primary Speaker Failure Screen



1. Press HELP to continue. The following message displays.

Figure 122. Speaker Failure Help Screen



2. Press BACK to display the speaker failure message again. The message cannot be cleared.
3. Press the ALARM SILENCE key to silence the slow-pulsing piezo tone.

Low and Critical Battery Conditions

Table 32. Low and Critical Battery Conditions

State	Critical Battery	Low Battery	AC Power	Operation
1	No	No	Yes	SpO2-normal AC/Battery charge LED-on LOW BATTERY LED-off LOW BATTERY message-off Audible alarm-off Error code-none Effect of ALARM SILENCE key-normal Shutdown-N/A
2	No	No	No	SpO2-normal AC/Battery charge LED-off LOW BATTERY LED-off LOW BATTERY message-off Audible alarm-off Error code-none Effect of ALARM SILENCE key-normal Shutdown- N/A
3	No	Yes	No	SpO2-normal AC/Battery charge LED-off LOW BATTERY LED-on LOW BATTERY message-on Audible alarm-low priority Error code-logged Effect of ALARM SILENCE key-First press silences audio alarm, second press cancels LOW BATTERY message (LED) stays on until Low Battery Condition is corrected. Shutdown-Imminent
4	No	Yes	Yes	SpO2-normal AC/Battery charge LED-on LOW BATTERY LED-on LOW BATTERY message-off Audible alarm-off Error code-logged Effect of ALARM SILENCE key-N/A (LED stays on) Shutdown-N/A
5	Not used			

Table 32. Low and Critical Battery Conditions

State	Critical Battery	Low Battery	AC Power	Operation
6	Yes	Yes	No	SpO2-not displayed AC/Battery charge LED-off LOW BATTERY LED-on (flashing) LOW BATTERY message-on Audible alarm-high priority Error code-displayed and logged Effect of ALARM SILENCEkey-none Shutdown-after 10 seconds
7	Yes	Yes	Yes	SpO2 - displayed. AC/Battery Charge LED - on LOW BATTERY LED-on (flashing) LOW BATTERY message - on The Battery Fuel Gauge shows a fully depleted battery (no bars lit). Warning message in the pleth window: UNIT WILL SHUT DOWN IF AC POWER LOST Audio alarm - low priority Error code - logged Effect of ALARM SILENCE key - One press silences the audible alarm. Pressing the ALARM Silence key twice cancels the LOW BATTERY message, removes the warning message and restores default display (LED continues to FLASH until Low Battery condition is not true, Battery Fuel Gauge shows charging progress) Shutdown - N/A

Table 33. Common Problems and Resolutions

Problem	Resolution
There is no response when I press the ON/STANDBY key.	<ul style="list-style-type: none"> • Ensure the supply voltage selector switch is set to the proper voltage. • A fuse may be malfunctioning. Notify a qualified service technician to check and, if necessary, replace the fuse. • If operating on battery power, the battery may be missing or discharged. If the battery is discharged, charge the battery, see <i>Monitoring Oximeter Power</i>, page 55. If the battery does not charge, notify a service personnel to replace the battery.
One or more display elements or indicators do not light during the power-on self-test (POST).	<ul style="list-style-type: none"> • Do not use the oximeter; contact qualified service personnel or your local Nellcor representative.
The oximeter is operating on battery power, even though it is connected to an AC power source.	<ul style="list-style-type: none"> • Ensure the supply voltage selector switch is set to the proper voltage. • Ensure the power cord is properly connected to the oximeter. • Check to see if power is available to other equipment on the same AC circuit.

Table 33. Common Problems and Resolutions

Problem	Resolution
<p>The Pulse Search Indicator is lit for more than 10 seconds (before any measurements are taken).</p>	<ul style="list-style-type: none"> • Check the OxiMax™ pulse oximetry sensor <i>Directions for Use</i> to confirm appropriate usage and proper application. Check sensor and pulse oximetry cable connections. Test the sensor on another patient and/or try another OxiMax pulse oximetry sensor or pulse oximetry cable. • Perfusion may be too low for the oximeter to track the pulse. Check the patient. Test the oximeter on someone else. Change the OxiMax pulse oximetry sensor site. Try another type of OxiMax pulse oximetry sensor. • Interference may be preventing the oximeter from tracking the pulse. Keep the patient still, if possible. Verify that the sensor is securely applied and replace it if necessary. Change the sensor site. Electromagnetic interference may be preventing the oximeter from tracking the pulse. Remove the source of interference and/or try to stabilize the environment. • Use a type of OxiMax pulse oximetry sensor that tolerates more patient movement; for example, an OxiMax adhesive sensor. • The OxiMax pulse oximetry sensor may be too tight, there may be excessive ambient light, or the sensor may be on an extremity with a blood pressure cuff, arterial catheter, or intravascular line. Reposition the sensor as necessary.
<p>The Pulse Search Indicator illuminates after successful measurements have been made.</p>	<ul style="list-style-type: none"> • Check the status of your patient. • Perfusion may be too low for the oximeter to track the pulse. Test the oximeter on another patient. Change the OxiMax pulse oximetry sensor site and/or try another type of OxiMax pulse oximetry sensor. • Interference may be preventing the oximeter from tracking the pulse. Verify the OxiMax pulse oximetry sensor is securely applied and replace it if necessary. Change the sensor site. Use a type of OxiMax pulse oximetry sensor that tolerates more patient movement; for example, an OxiMax adhesive sensor. Electromagnetic interference may be preventing the oximeter from tracking the pulse. Remove the source of interference and/or try to stabilize the environment. • The OxiMax pulse oximetry sensor may be too tight, there may be excessive ambient light, or the sensor may be on an extremity with a blood pressure cuff, arterial catheter, or intravascular line. Reposition the sensor as necessary.
<p>Error Code: “EEE XXX” followed by a number appears.</p>	<ul style="list-style-type: none"> • Press the ON/STANDBY key and allow the oximeter to shut off completely. Then press the softkey again to turn back on the oximeter. <p>If the error code persists, record the number and provide this information to a qualified service technician, or your local Nellcor representative.</p> <ul style="list-style-type: none"> • Error Code “EEE 529 or 729” displays when the battery discharges to a critically low level. <p>Ensure the SUPPLY VOLTAGE SELECTOR switch on the rear panel is set to the proper voltage based on your location.</p> <ul style="list-style-type: none"> • Press the ON/STANDBY key and allow the oximeter to shut off completely. Allow the battery to charge for about ten minutes and then turn back on the unit. <p>If the error code is still present, turn the unit off and allow it to continue to charge. If the oximeter has been charged for 30 minutes and the error code persists, contact Nellcor’s Technical Services Department at 1.800.635.5267 or your local Nellcor representative. See <i>Error Codes for Non-correctable Failures</i>, page 146.</p>

Obtaining Technical Assistance

For technical information and assistance, to order parts, or to order an *N-600x Service Manual*, contact Nellcor's Technical Services Department at 1.800.635.5267 or your local Nellcor representative. The *N-600x Service Manual* includes block diagrams, schematics, and a parts list required by qualified personnel when servicing the oximeter.

When calling Nellcor's Technical Services Department, or your local Nellcor representative, have the oximeter serial number, as well as the firmware version number of your oximeter.

The firmware version appears in the oximeter display each time the oximeter successfully completes the power-on self-test. Write the number down and have it available whenever requesting technical assistance.

Returning your Oximeter

Contact Nellcor's Technical Services Department at 1.800.635.5267 or your local Nellcor representative for shipping instructions, including a Returned Goods Authorization (RGA) number. Unless otherwise instructed by Nellcor's Technical Services Department, it is not necessary to return the sensor or other accessory items with the oximeter. Pack the oximeter in its original shipping carton. If the original carton is not available, use a suitable carton with the appropriate packing material to protect it during shipping. See *Packing the Oximeter for Shipment*, page 184.

Return the oximeter by any shipping method that provides proof of delivery.



13 Ordering Oximeter Spare Parts

Overview

This section describes how to order spare parts for the OxiMax N-600x™ pulse oximeter. Spare parts are shown in Table 34, *Spare Parts List by Call-out Number*, on page 163. Item numbers correspond to the call-out numbers in *Exploded View*, Figure 123 on page 162.

This manual is available on the Internet at:

<http://www.nellcor.com/serv/manuals.aspx>

Ordering Replacement Parts

Nellcor's Technical Services provides technical assistance information and replacement parts. Contact Nellcor or your local Nellcor representative to obtain replacement parts. Refer to parts by the part names and part numbers.

A listing of the spare parts and accessories for the OxiMax N-600x pulse oximeter is on the Internet at:

<http://www.nellcor.com>

Spare Parts List

The figure below shows the OxiMax N-600x pulse oximeter expanded view. See the *Spare Parts List by Call-out Number*, page 163 for descriptions and part numbers.

Figure 123. Exploded View

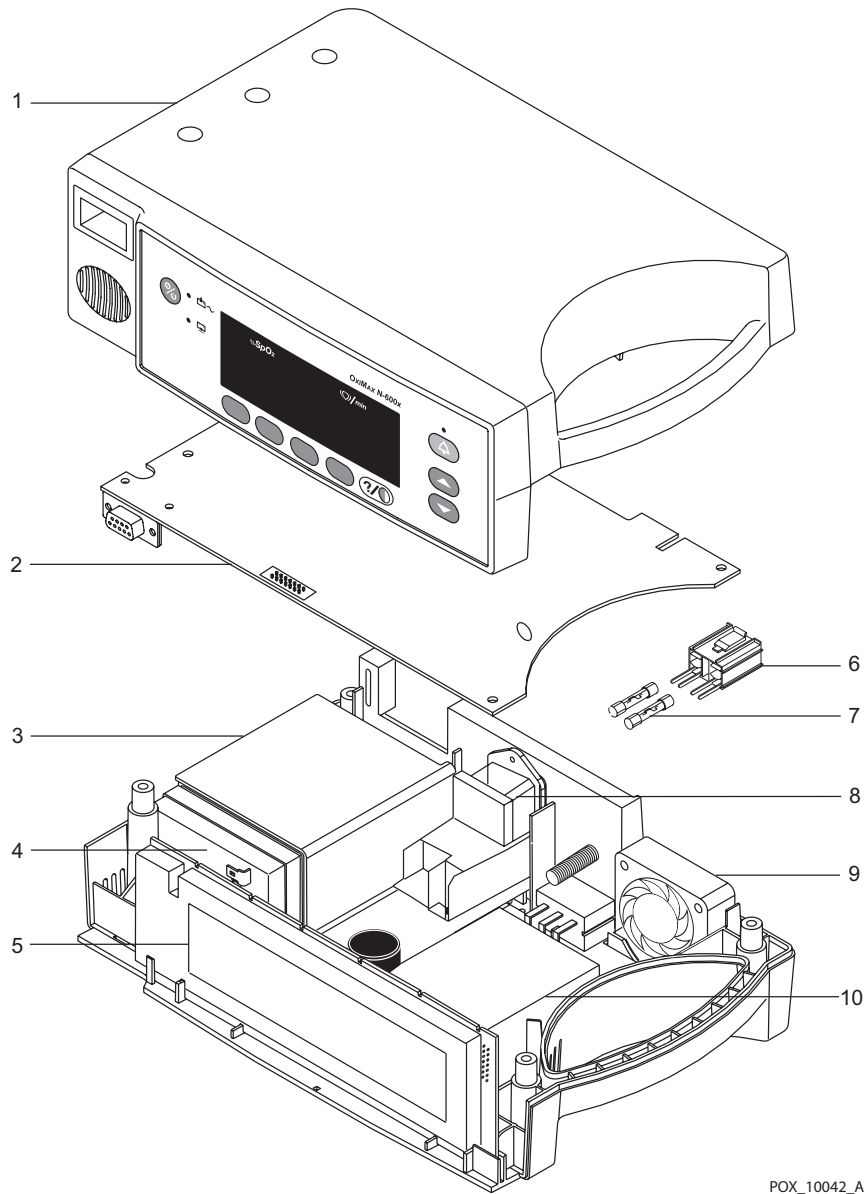

POX_10042_A

Table 34. Spare Parts List by Call-out Number

Item	Description	Part Number
1	Top Enclosure with Membrane Switch	10009087
2	Main Board or Main PCB	SP10014868
3	Battery Bracket	035307
4	Battery	640119
5	Display PCB	SP10006091
6	Fuse Drawer	691500
7	Fuses	691032
8	Power Entry Module	10004406
9	Cooling Fan	10003713
10	Power Supply Board or LPS PCB	SP10017371
...	Alarm Speaker (not shown)	SP10003280
...	Rubber Feet (not shown)	4-003818-00
...	Power Cord U.S.A. (not shown)	049798
...	Power Cord U.K. (not shown)	901863
...	Tilt Stand (not shown)	036702
...	GCX Roll Stand (not shown) Includes basket and handle, but not adapter plate	10002385
...	GCX Mounting Plate (not shown)	10002622

Table 35. Spare Parts List by Part Number

Item	Part Number	Description
3	035307	Battery Bracket
...	036702	Tilt Stand (not shown)
...	049798	Power Cord U.S.A. (not shown)
4	640119	Battery
7	691032	Fuses
6	691500	Fuse Drawer
...	901863	Power Cord U.K. (not shown)
9	10003713	Cooling Fan
...	10002385	GCX Rollstand (not shown) Includes basket and handle, but not adapter plate
...	10002622	GCX Mounting Plate (not shown)
8	10004406	Power Entry Module
1	10009087	Top Enclosure with Membrane Switch
...	4-003818-00	Rubber Feet (not shown)
...	SP10003280	Alarm Speaker (not shown)
5	SP10006091	Display PCB
10	SP10017371	Power Supply Board or LPS PCB
2	SP10014868	Main Board or Main PCB

14 Repairing the Oximeter

Overview



WARNING

Only qualified service personnel should open the oximeter housing, remove and replace components, or make adjustments. If your medical facility does not have a qualified service technician, please contact Nellcor's Technical Services or your local Nellcor representative.



WARNING

Before attempting to open or disassemble the OxiMax N-600x pulse oximeter, disconnect the power cord to avoid possible injury.



WARNING

No user serviceable parts inside.



Caution

Observe ESD (electrostatic discharge) precautions when working within the unit.

OxiMax N-600x™ pulse oximeter major component parts include all PCBs and subassemblies.

- PCBs
- Battery
- Cables
- Chassis enclosures

Collect the following tools prior to any disassembly of the oximeter.

- Small- and medium-sized phillips-head screwdriver
- Small flat-blade screwdriver
- Needle nose pliers or 1/4-inch socket with driver
- 10mm wrench
- Torque wrench, 10-in lbs. (1.13 Newton-meters)



Note:

The battery charge procedure should be performed before oximeter repairs when possible.

Only a qualified service technician may disassemble the oximeter to its major component parts. The supported replacement level for the OxiMax N-600x pulse oximeter is to the printed circuit board (PCB) and major subassembly level. After isolating the problem to a suspected PCB, follow the procedures in *Disassembling the*

Oximeter, page 167, then proceed to replace the faulty PCB with a known good PCB. Verify the symptom disappears and ensure the oximeter passes all performance tests. If the symptom persists, swap the replacement PCB with the suspected malfunctioning PCB (the original PCB installed when you started troubleshooting) and continue troubleshooting.



Note:

Some spare parts come with an enclosed business reply card. After receiving the spare parts, please complete and return the business reply card.

Fuse Replacement

To replace external fuses:

1. Turn the oximeter off by pressing the ON/STANDBY button.
2. Disconnect the oximeter from the AC power source.
3. Disconnect the power cord from the back of the oximeter.
4. Remove the fuse drawer from the power module by pressing down on the tab in the center and pulling out as shown.

Figure 124. External Fuse Removal

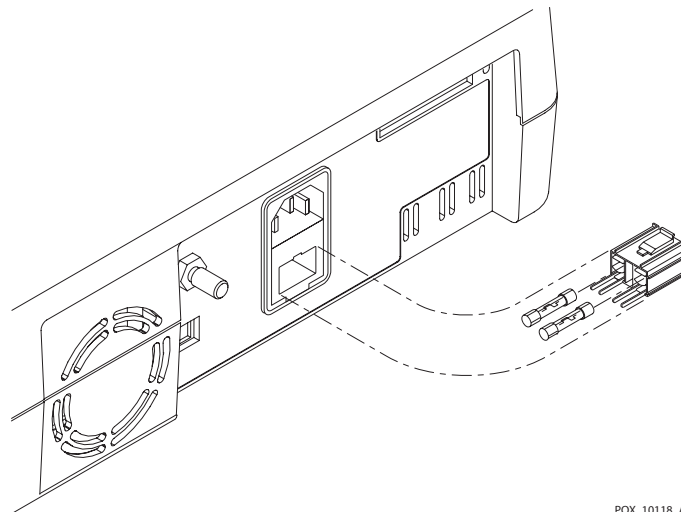

5. Put two (2) new, 5 x 20-mm, slow blow, 0.5-amp, 250-volt fuses in the drawer and reinsert the drawer in the power entry module.

Oximeter Disassembly and Reassembly

Disassembling the Oximeter



Caution

Observe ESD (electrostatic discharge) precautions when disassembling and reassembling the OxiMax N-600x pulse oximeter and when handling any of the components of the oximeter.



Note:

The battery charge procedure should be performed before oximeter repairs when possible.

To disassemble the oximeter:

1. Turn the oximeter off by pressing the ON/STANDBY button.
2. Disconnect the oximeter from the AC power source.
3. Set the oximeter upside down on a static-free work surface.



Caution

Ensure the work surface is clean and free of debris.

4. Using the phillips-head screwdriver, loosen and then remove the oximeter's four corner screws.

Figure 125. Removing the Corner Screws

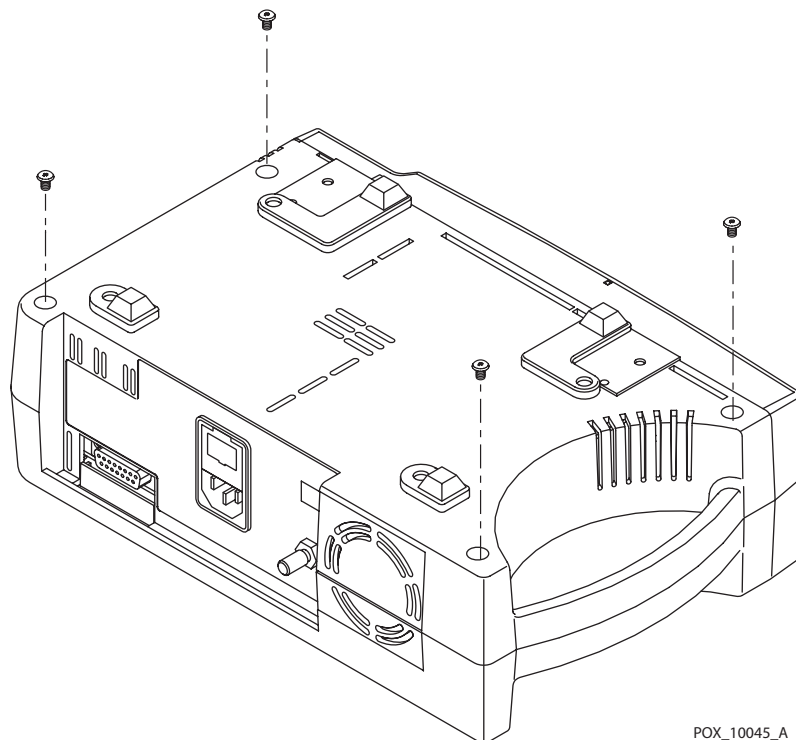

POX_10045_A

5. Set aside all four screws for use during reassembly.
6. Carefully set the oximeter right-side up, grasping both halves to prevent premature separation.

7. Separate the oximeter's top and bottom cases without stressing the connection harnesses between the cases.



Caution

To avoid stress or damage to the power supply wiring harness, ensure the top enclosure is lying flat on the work surface.

8. Place the two halves of the oximeter on the static-free work surface.
9. Disconnect the oximeter's power supply harness from J200 (3) located on the Main Board printed circuit board (PCB).

Figure 126. Opening the Oximeter Casing

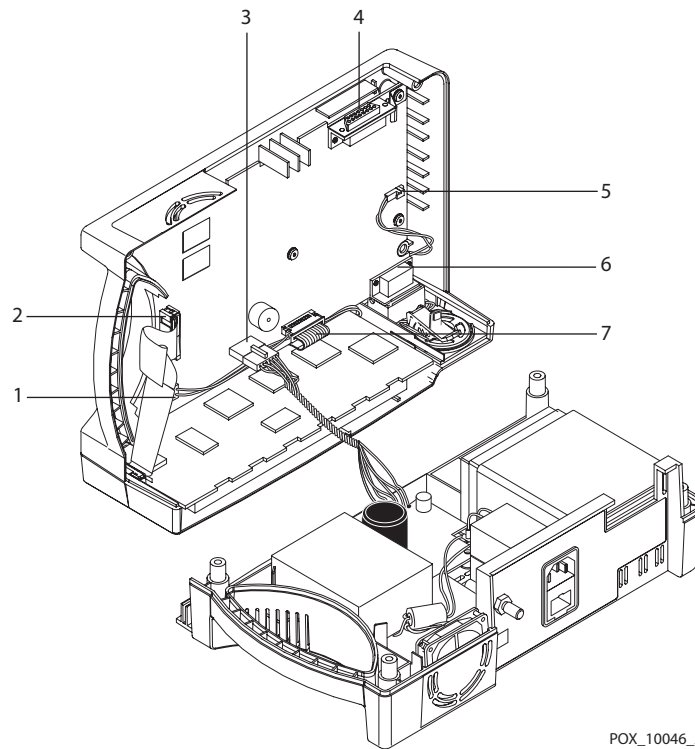

POX_10046_A

Table 36. Opening Oximeter Casting Figure Callouts

No	Description
1	J4 Connector
2	J7 Connector
3	J200 Connector
4	J10 Connector
5	J9 Connector
6	J3 Connector
7	J2 Connector

Reassembling the Oximeter

To reassemble the oximeter:

1. Connect the oximeter's power supply harness to J200 (3) on the Main Board PCB.
2. Place the oximeter's top enclosure over the bottom case, being careful to align the Display PCB, Power Entry Module, and the fan with the slots in the oximeter casing.



Caution

Do not pinch any wires between the cases when reassembling the oximeter. Before installing the screws, inspect the entire edge of the union for even seating.

3. Grasp both halves, gently rotating it upside-down.
4. Place on a static-free work surface.
5. Replace the four corner screws set aside during disassembly in the bottom cover of the unit.
6. Gently tighten the screws that hold the case halves together (10-in lbs. maximum).



Caution

Overtightening could strip out the screw holes in the top enclosure, rendering it unusable.

Battery Replacement

Removing the Old Battery

To remove the old battery:

1. Turn the oximeter off by pressing the ON/STANDBY button.
2. Disconnect the oximeter from the AC power source.
3. Follow the steps in *Disassembling the Oximeter*, page 167.
4. Remove the two screws from the battery bracket and lift the battery out of the bottom case as shown.
5. Be sure to note the polarity of the leads. Use needle-nose pliers to disconnect the leads from the battery.

Figure 127. Removing the Battery

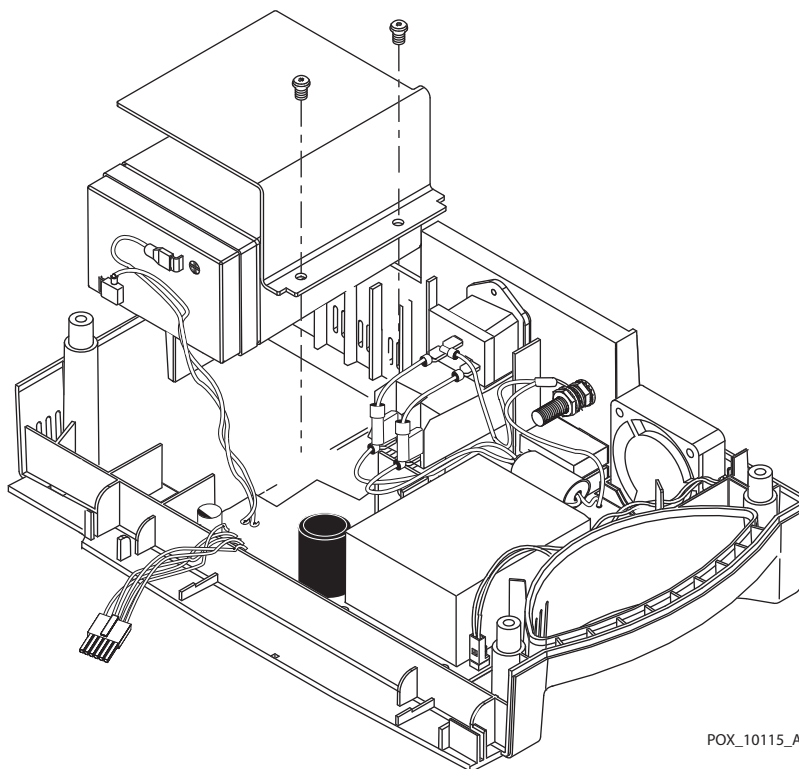

Caution

The lead-acid battery is recyclable. Do not dispose of the battery by placing it in the regular trash. Dispose of the battery in accordance with local guidelines or contact Nellcor's Technical Services department to arrange for disposal.

Replacing the Battery

To replace the old battery:

1. Follow the steps outlined in *Removing the Old Battery*, page 170.
2. Connect the leads to the battery. The red wire connects to the positive terminal, and the black wire connects to the negative terminal.
3. Insert the new battery into the bottom case with the negative terminal towards the outside of the oximeter. Install the bracket and grounding lead with the two screws.
4. Follow the steps outlined in *Reassembling the Oximeter*, page 169.
5. Power the oximeter on to verify proper operation.

Power Entry Module (PEM) Replacement

Removing the Power Entry Module

1. Turn the oximeter off by pressing the ON/STANDBY button.
2. Disconnect the oximeter from the AC power source and follow the steps outlined in *Disassembling the Oximeter*, page 167.
3. Push the top of the Power Entry Module (PEM) in from the outside of the case, and lift up.
4. Use needle-nose pliers to disconnect the leads from the PEM as shown.

Figure 128. Removing the Power Entry Module

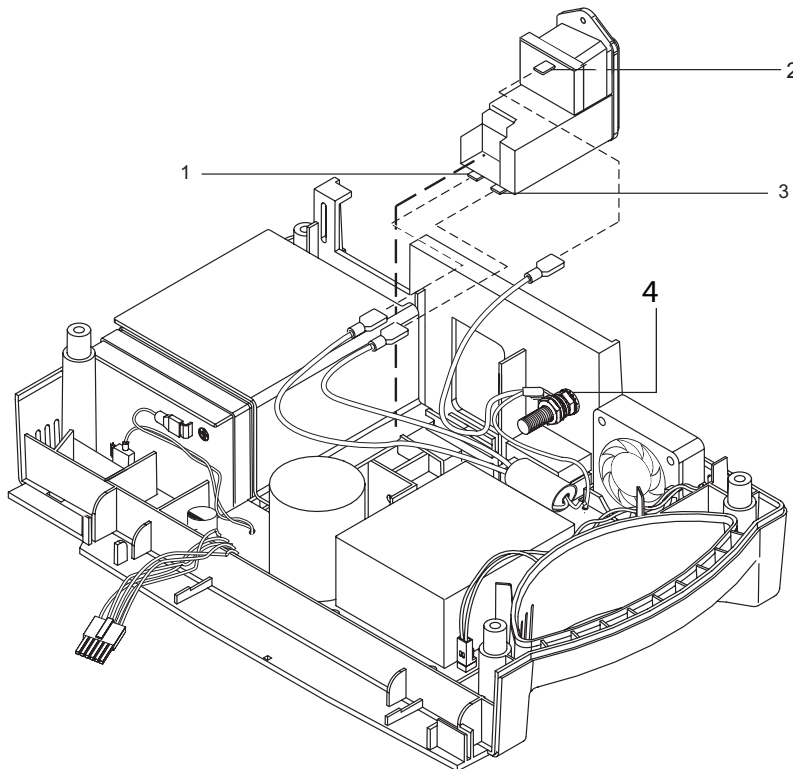

POX_10044_A

Table 37. Removing the PEM Figure Callouts

No	Description
1	N Connector
2	G Connector
3	L Connector
4	Equipotential Terminal (Ground)

Replacing the Power Entry Module

To replace the power entry module:

1. Reconnect the three power supply leads as indicated in *Removing the Power Entry Module*, page 172.
2. Install the PEM in the bottom case with the fuse drawer facing down. A tab in the bottom case holds the PEM in place.
3. Insert the bottom wing of the PEM between the tab and the internal edge of the sidewall of the bottom case.
4. Push the PEM down and towards the outside of the oximeter until it clicks into place.
5. Follow the steps in *Reassembling the Oximeter*, page 169.

Power Supply Replacement

Removing the Power Supply

To remove the power supply:

1. Turn the oximeter off by pressing the ON/STANDBY button.
2. Disconnect the oximeter from the AC power source and follow the steps outlined in *Disassembling the Oximeter*, page 167.
3. Push the top of the Power Entry Module (PEM) in from the outside of the case, and lift up.
4. Use needle-nose pliers to disconnect the three leads from the PEM shown in *Removing the Power Entry Module*, page 172.
5. Disconnect the fan wire harness from J1 (1) on the Power Supply PCB as shown.
6. Use a 10mm wrench to disconnect the power supply ground lead from the equipotential terminal shown in *Removing the Power Entry Module*, page 172.
7. Use needle-nose pliers to remove the two leads connected to the battery.
8. Remove the seven screws as shown.
9. Lift the power supply out of the bottom case.

Figure 129. Removing the Power Supply

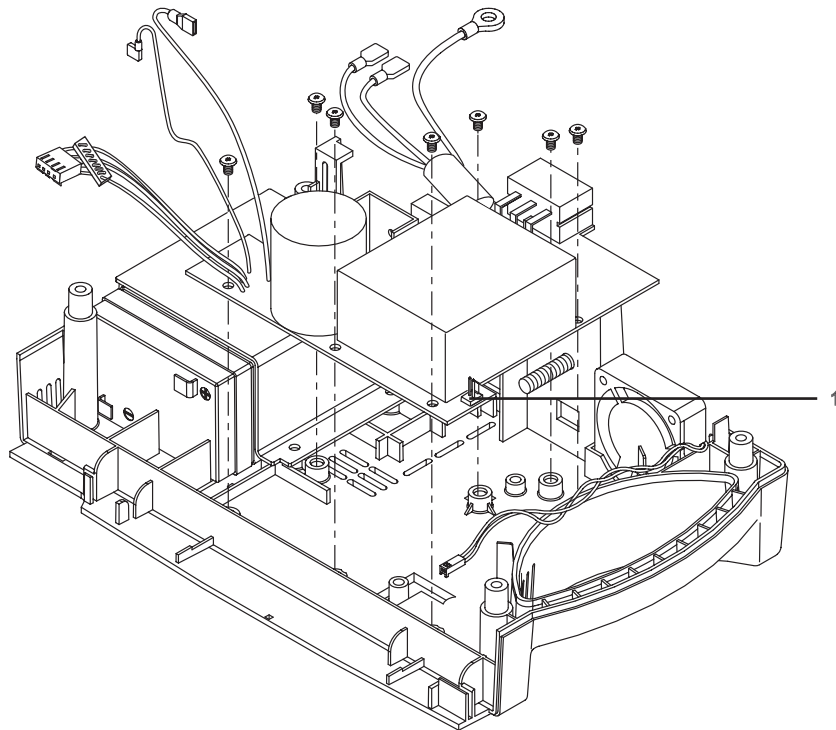

POX_10043_A

Replacing the Power Supply

To replace the power supply:

1. Reconnect the three leads to the PEM and the leads to the equipotential terminal and the battery, shown in *Removing the Power Entry Module*, Figure 128 on page 172.
2. Place the power supply in the bottom case.

Table 38. Power Supply Lead Connections

Wire Color / Label	Connect To
Green & Yellow	Equipotential Lug
Brown/Labeled "L"	"L" on the Power Entry Module
Blue/Labeled "N"	"N" on the Power Entry Module
Red/Labeled "+"	Positive Battery Terminal
Black/Labeled "-"	Negative Battery Terminal



Caution

When installing the power supply, tighten the seven screws using a 4-in lbs maximum. Overtightening could strip out the screw holes in the bottom case, rendering it unusable.

3. Install the seven screws in the power supply and tighten.
4. Connect the fan harness to J1 on the power supply.
5. Install the PEM in the bottom case with the fuse drawer facing down. A tab in the bottom case holds the PEM in place.
6. Insert the bottom wing of the PEM between the tab and the internal edge of the sidewall of the bottom case.
7. Push the PEM down and towards the outside of the oximeter until it clicks.
8. Follow the steps outlined in *Reassembling the Oximeter*, page 169.

Cooling Fan Replacement

Removing the Cooling Fan

To remove the cooling fan:

1. Turn the oximeter off by pressing the ON/STANDBY button.
2. Disconnect the oximeter from the AC power source and follow the steps outlined in *Disassembling the Oximeter*, page 167.
3. Disconnect the fan wire harness from J1(1) on the Power Supply PCB as shown.
4. Lift the cooling fan from the slots in the bottom case.

Figure 130. Removing the Cooling Fan

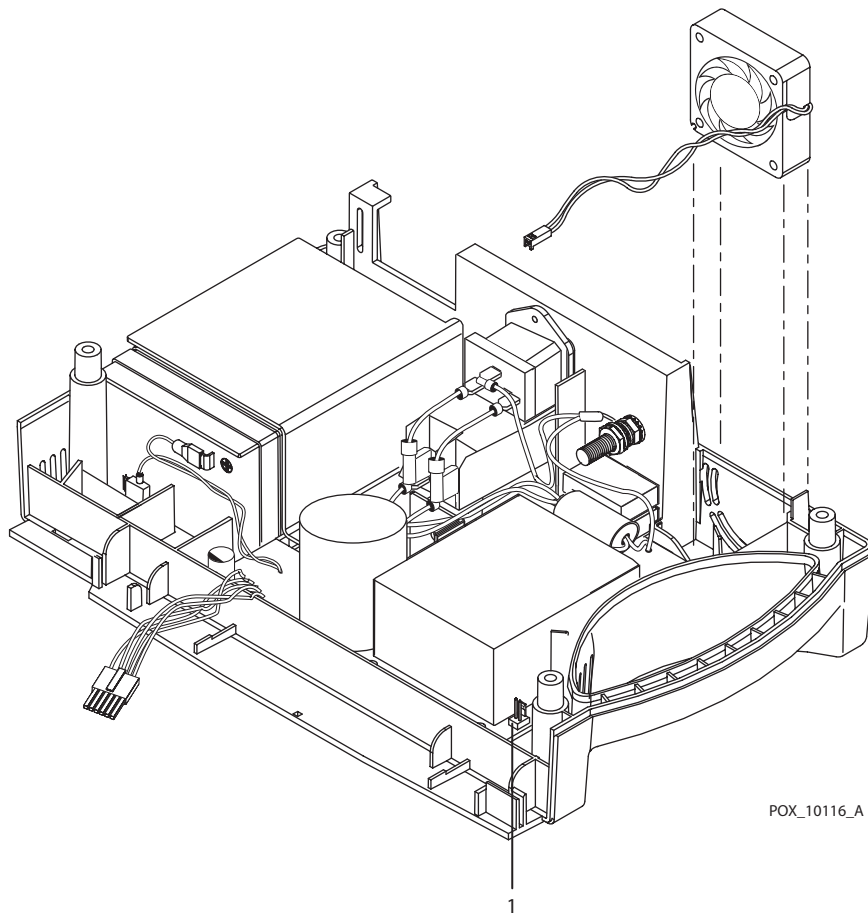

POX_10116_A

Replacing the Cooling Fan

To replace the cooling fan:

1. Connect the cooling fan wire harness to J1 on the Power Supply PCB.
2. Insert the cooling fan into the slots with the padded sides.
3. Follow the steps outlined in *Reassembling the Oximeter*, page 169.

Display PCB Replacement

Removing the Display PCB



WARNING

The LCD panel contains toxic chemicals. Do not touch broken LCD panels. Physical contact with a broken LCD panel can result in transmission or ingestion of toxic substances.

To remove the Display PCB:

1. Turn the oximeter off by pressing the ON/STANDBY button.
2. Disconnect the oximeter from the AC power source and follow the steps outlined in *Disassembling the Oximeter*, page 167.
3. Disconnect the Cold Cathode Fluorescent Light (CCFL) harness from J4 (6) of the Main Board PCB as shown.

Figure 131. Removing the Display PCB

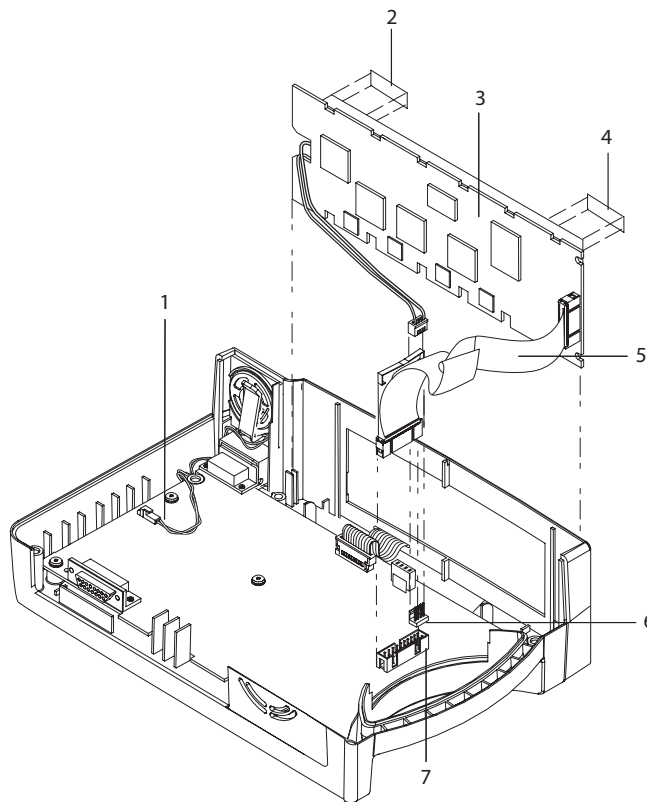

POX_10041_A

Table 39. Opening Oximeter Casting Figure Callouts

No	Description
1	Speaker wires to J9 Connector on Main PCB

Table 39. Opening Oximeter Casting Figure Callouts

No	Description
2	Double-sided tape
3	Display PCB
4	Double-sided tape
5	Display ribbon cable
6	CCFL wires to J4 Connector on Main PCB
7	Display ribbon cable to J7 Connector on Main PCB

4. Use a small blade screwdriver to remove the clip from either edge of J7 (7), then disconnect the Display PCB ribbon cable (5) from the connector. Leave the speaker wire (1) attached.
5. Separate the adhesive connection of the double-sided tape(2 & 4) and lift the Display PCB up to remove it from the top case.
6. Remove and discard the used double-sided tape.

Replacing the Display PCB

To replace the Display PCB:

1. Install new double-sided tape as shown in *Removing the Display PCB*, Figure 131 on page 177.
2. Slide the Display PCB into the grooves in the top case.
3. Ensure the Display PCB is firmly seated in the top case.
4. Apply pressure between the top case and the Display PCB to make good contact with the double-sided tape.
5. Connect the CCFL wire harness with two white wires to J4 on the Main Board PCB.
6. Connect the Display PCB ribbon cable to J7 on the Main Board PCB. Install the clip over the J7 connector.
7. Follow the steps outlined in *Reassembling the Oximeter*, page 169.

Main Board PCB Replacement

Removing the Main Board PCB

To remove the Main Board PCB:

1. Turn the oximeter off by pressing the ON/STANDBY button.
2. Disconnect the oximeter from the AC power source and complete the steps outlined in *Disassembling the Oximeter*, page 167.
3. Disconnect the CCFL harness (two white wires) from J4 of the Main Board PCB. See *Removing the Display PCB*, Figure 131 on page 177.
4. Use a small blade screwdriver to open the clip from either edge of J7, then disconnect the Display PCB ribbon cable from the connector.
5. Disconnect the keypad ribbon cable from connector J2 on the Main Board PCB. See *Removing the Display PCB*, Figure 131 on page 177.
6. Lift up on the ribbon cable's outer shell until it clicks, then remove the cable from the connector.
7. Disconnect the speaker cable from J9 on the Main Board PCB.
8. Remove the six screws in the Main Board PCB as shown.
9. Remove the Main Board PCB from the top case.

Figure 132. Removing the Main Board PCB

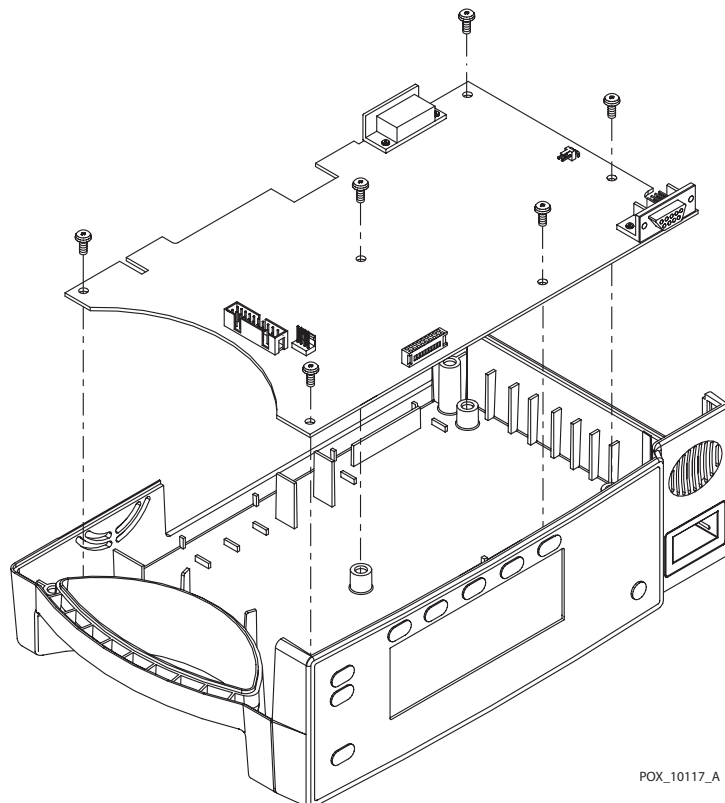

POX_10117_A

Replacing the Main Board PCB



Caution

When installing the Main Board PCB, hand-tighten the six screws (4-in lbs maximum). Overtightening could strip out the screw holes in the top case, rendering it unusable.

To replace the Main Board PCB:

1. Place the Main Board PCB in the top case.
2. Install the six screws in the Main Board PCB.
3. Lift up on the outer shell of *J2 Removing the Display PCB*, Figure 131 on page 177, on the Main Board PCB until it clicks into place.
4. Insert the keypad ribbon cable into J2 on the Main Board PCB.
5. Slide the outer shell of J2 down until it locks in place.
6. Insert the J200 cable into the Main Board PCB until it locks into place.
7. Connect the speaker cable to J9 on the Main Board PCB.
8. Connect the CCFL wire harness with two white wires to J4 on the Main Board PCB.
9. Connect the Display PCB ribbon cable to J7 on the Main Board PCB. Install the clip over the J7 connector.
10. Follow the steps outlined in *Reassembling the Oximeter*, page 169.

Alarm Speaker Replacement

Removing the Alarm Speaker



WARNING

If replacing the speaker because of speaker failure, please contact Nellcor Technical Services or your local Nellcor representative.



Note:

Contact Nellcor Technical Services to discuss the return or disposal of the original speaker assembly.

To remove the alarm speaker:

1. Turn the oximeter off by pressing the ON/STANDBY button.
2. Disconnect the oximeter from the AC power source and follow the steps outlined in *Disassembling the Oximeter*, page 167.
3. Disconnect the speaker wire harness from J9 (1) on the Main Board PCB as shown.
4. Pull the holding clip (2) back from the speaker and lift the speaker out of the top case.

Figure 133. Removing the Alarm Speaker

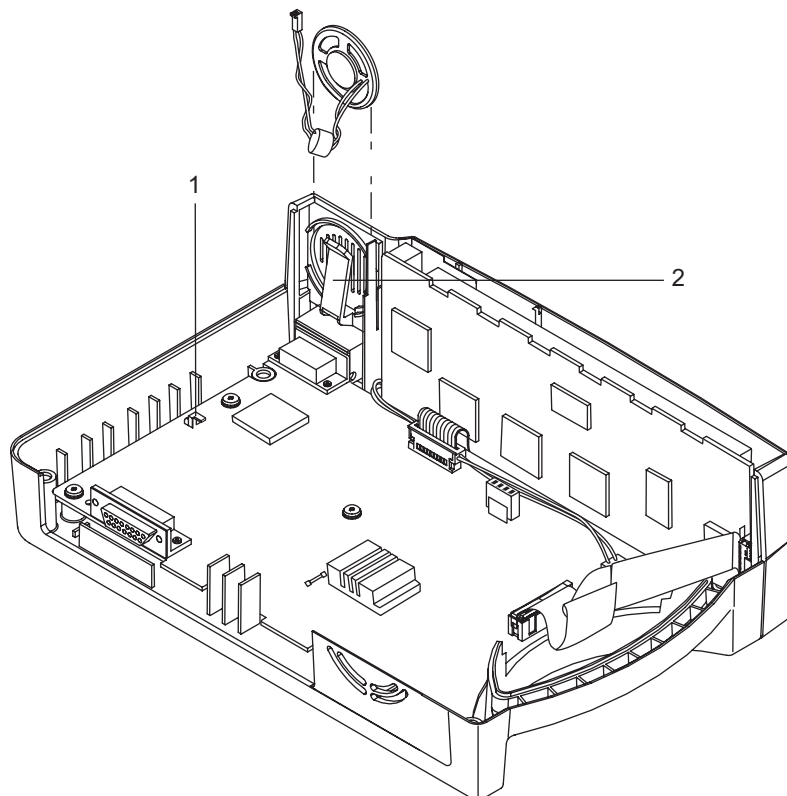

POX_10040_A

5. Remove the speaker by gently releasing the retaining tab and sliding the speaker assembly from its mounting.



Caution

Avoid using excessive force when pressing the speaker retaining tab.

6. Set aside or discard the original speaker assembly, so it will not be mixed with its replacement.

Replacing the Alarm Speaker

To replace the alarm speaker:



WARNING

Do not allow other metal objects to come into contact with the speaker; permanent damage may occur.



Caution

Handle the speaker **ONLY** by the edges of the metal ring to avoid damage.

1. Pull the holding clip back, and insert the speaker into the top case.
2. Connect the speaker wire harness to J9 on the Main Board PCB.
3. Follow the steps outlined in *Reassembling the Oximeter*, page 169.

Top Case Assembly Replacement

Removing the Top Case Assembly

To remove the top case assembly:

1. Turn the oximeter off by pressing the ON/STANDBY button.
2. Disconnect the oximeter from the AC power source and follow the steps outlined in *Disassembling the Oximeter*, page 167.
3. Follow the steps outlined in *Main Board PCB Replacement*, page 179.

Replacing the Top Case Assembly



Caution

When installing the Main Board PCB, hand-tighten the six screws (4-in lbs. maximum). Overtightening could strip out the screw holes in the top enclosure, rendering it unusable.

1. Complete the steps outlined in *Main Board PCB Replacement*, page 179.
2. Reconnect the oximeter to an AC power source.
3. Turn the oximeter on by pressing the ON/STANDBY button.

Packing the Oximeter for Shipment

Shipment Requirements



Caution

Pack the oximeter carefully. Failure to follow the packing instructions outlined in this section may result in loss or damage not covered by any applicable Nellcor warranty.

This section describes how to return your oximeter. Contact Nellcor's Technical Services Department or your local Nellcor representative for shipping instructions, including a Returned Goods Authorization (RGA) number. Unless otherwise instructed by Nellcor's Technical Services or your Nellcor representative, it is not necessary to return the OxiMax pulse oximetry sensor or any other accessory items with the oximeter.

To pack an oximeter for return to the manufacturer:

1. Prior to shipping the oximeter, contact your supplier or local Nellcor office (Technical Services Department) for a returned goods authorization number (RGA).
2. Pack the oximeter in a shipping carton by one of two methods.
 - a. **Original Carton**—Pack the oximeter in its original shipping carton. Reference *Using the Original Carton*, page 184.
 - b. **Generic Carton**—If the original carton is unavailable, use a suitable carton with appropriate packing material to protect the oximeter during shipping. Reference *Using a Generic Carton*, page 185.



Note:

If the original shipping carton is not available, use another suitable carton; North American customers may call Nellcor's Technical Services to obtain a shipping carton.

3. Label the shipping carton and any shipping documents with the returned goods authorization number.
4. Return the oximeter by any shipper that provides proof of delivery confirmation.

Using the Original Carton



Caution

Pack the oximeter carefully. Failure to follow the packing instructions outlined in this section may result in loss or damage not covered by any applicable Nellcor warranty.

To repack the oximeter using the original carton:

1. Place the oximeter and, if necessary, accessory items in original packaging.

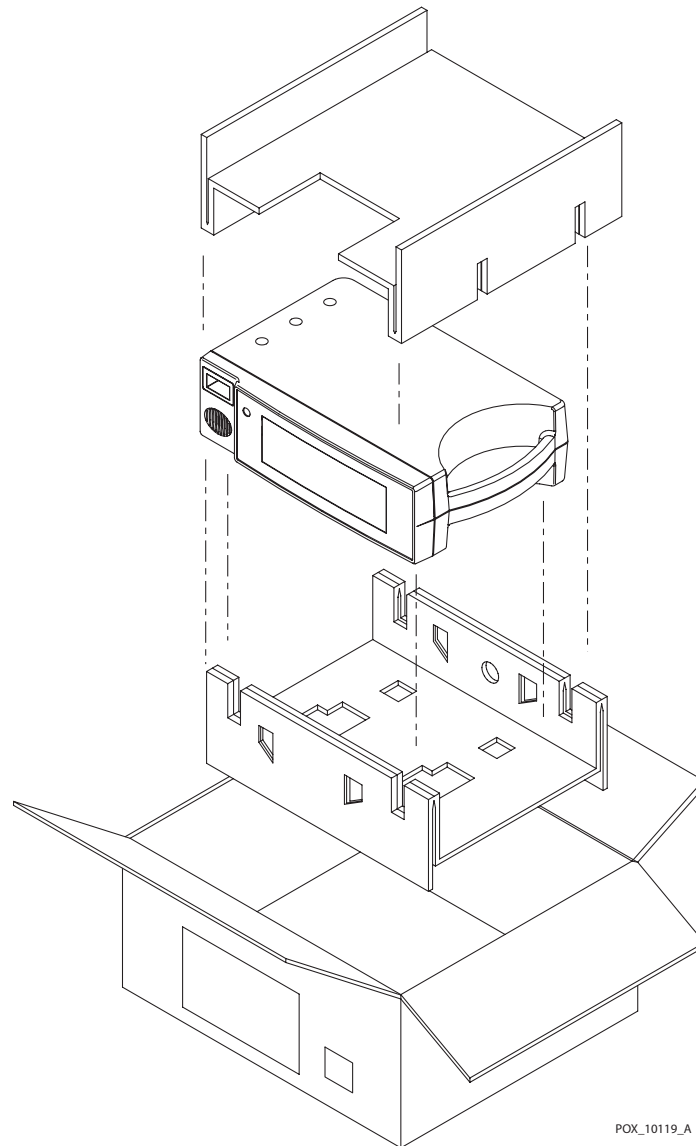
Figure 134. Packing

2. Place in shipping carton and seal the carton with packing tape.
3. Label the carton with a shipping address, return address, and RGA number, if applicable.

Using a Generic Carton**Caution**

Pack the oximeter carefully. Failure to follow the packing instructions outlined in this section may result in loss or damage not covered by any applicable Nellcor warranty.

To repack the oximeter using a generic carton:

1. Place the oximeter in a plastic bag.
2. Locate a corrugated cardboard shipping carton with a bursting strength of at least 200 lbs. per square inch (psi).
3. Fill the bottom of the carton with at least two inches of packing material.
4. Place the bagged unit on the layer of packing material and fill the box completely with packing material.
5. Seal the carton with packing tape.
6. Label the carton with the shipping address, return address, and RGA number, if applicable.

15 Oximeter Schematics

Overview

This section focuses specifically on OxiMax N-600x™ pulse oximeter Main Printed Circuit Board (PCB) schematics.

1. Microprocessor, EEPROM, RTC, RESET circuitry
2. Logic Analyzer, Hard Reset, FLASH, Fast and Overlay SRAM circuitry
3. SIP/SOP Interface circuitry A
4. SIP/SOP Interface circuitry B
5. Sound and VEE circuitry
6. Main Power Supply, Power Control, and Check circuitry
7. Display Interface circuitry
8. Battery-backed Trend RAM, LED Drivers, and I/O Decode circuitry
9. FE102 Isolated Power Supply circuitry
10. FE102 Isolated Interface 10-base T Ethernet circuitry
11. Oxichip, Front End Power, LED Channels circuitry
12. Front End Microcontroller circuitry
13. Warmer Power Supply and Control circuitry

In addition, this section includes a front and rear assembly drawing of the Main Printed Circuit Board (PCB) and a power supply schematic.

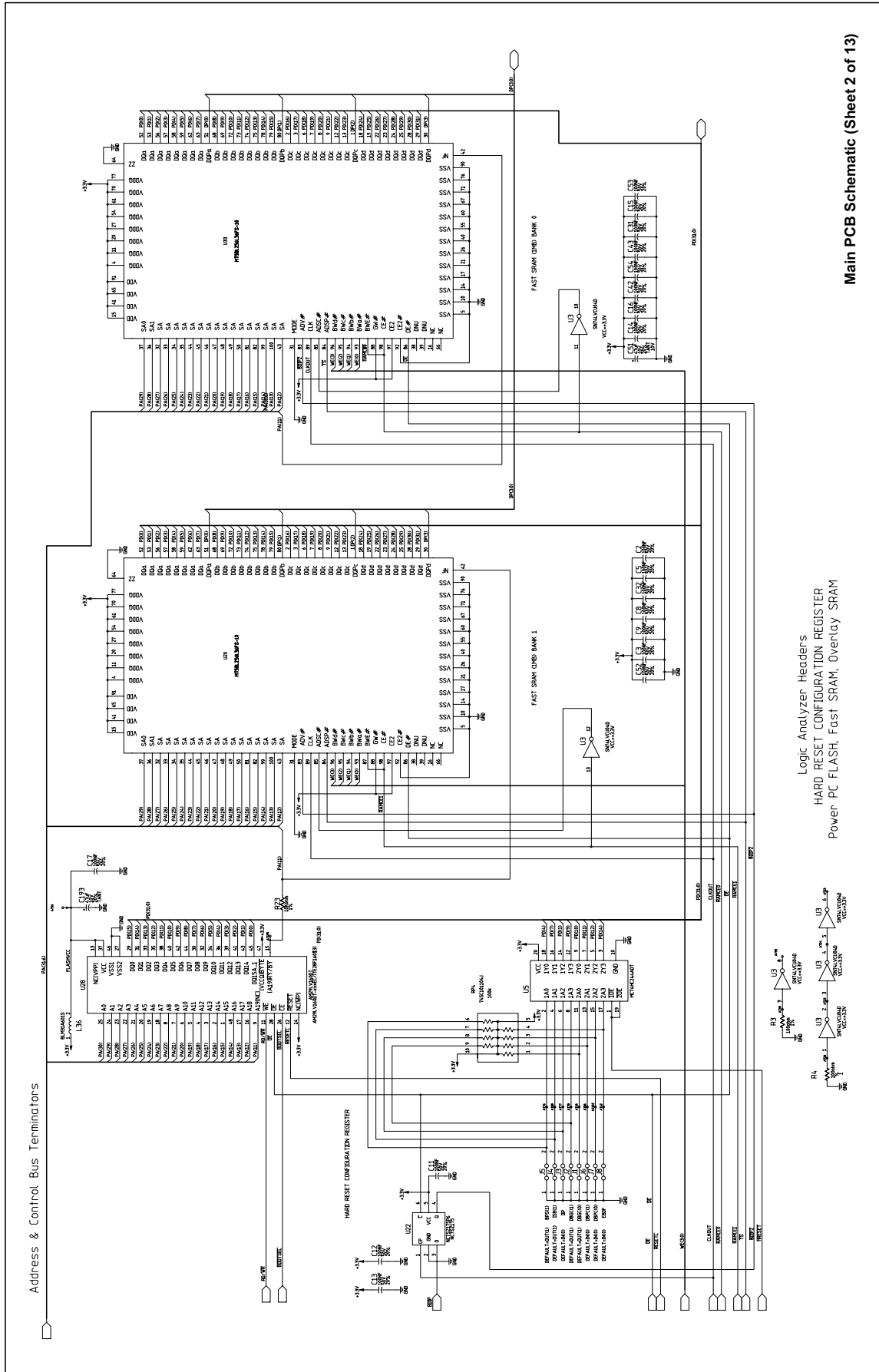

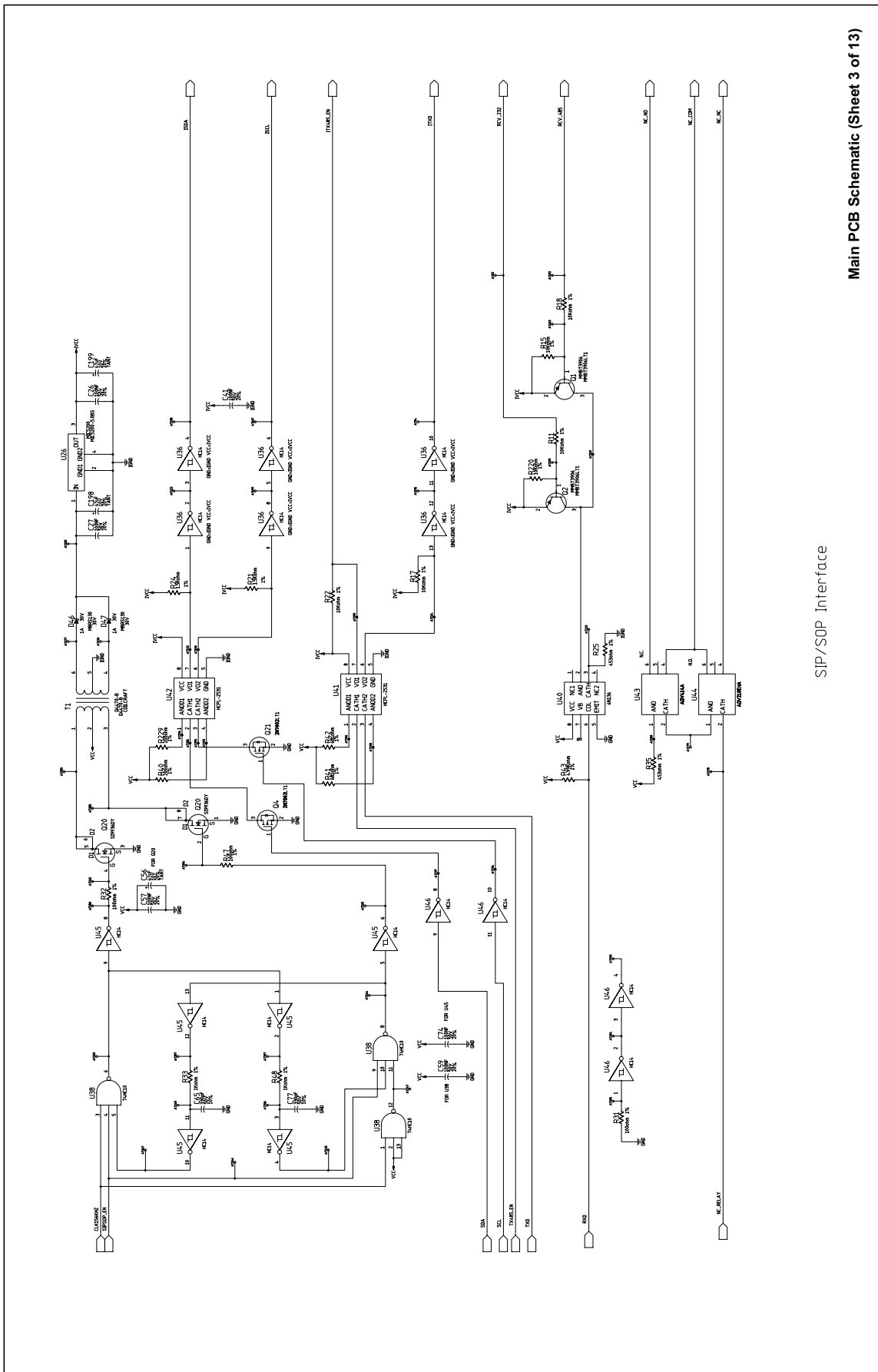

Main PCB Schematic (Sheet 3 of 13)

SIP/SOP Interface

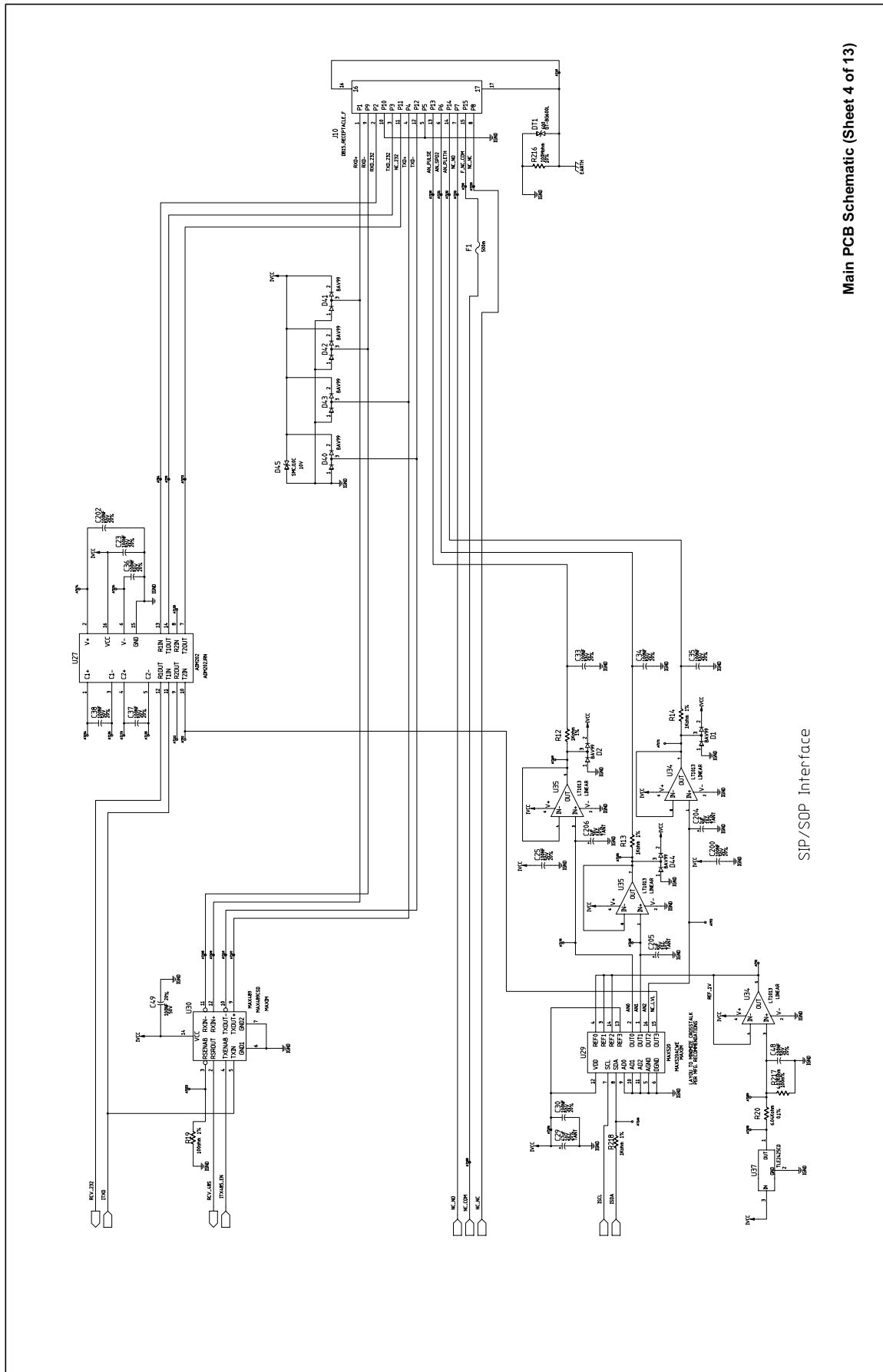

Main PCB Schematic (Sheet 4 of 13)

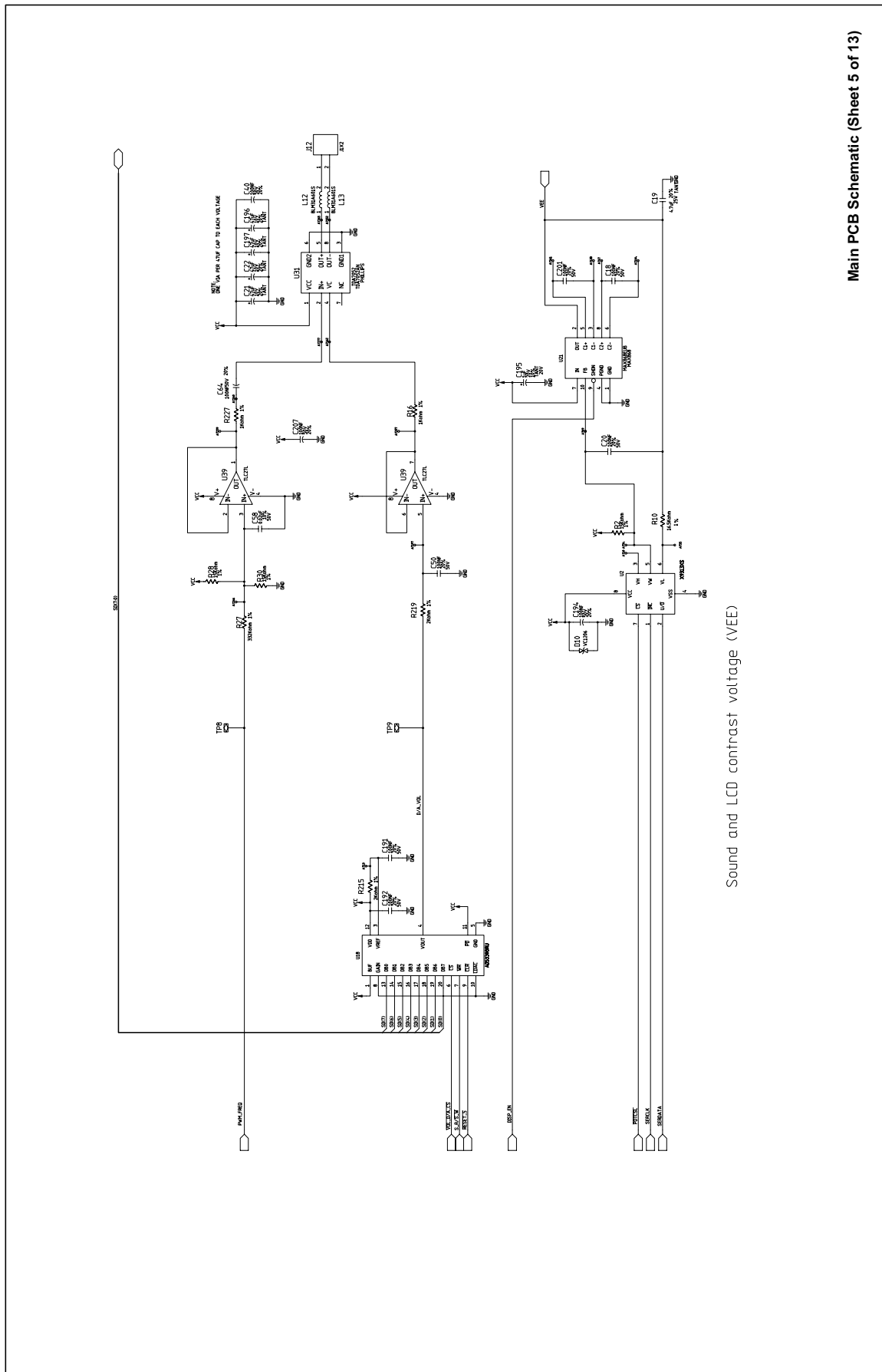

Main PCB Schematic (Sheet 5 of 13)

Sound and LCD contrast voltage (VEE)

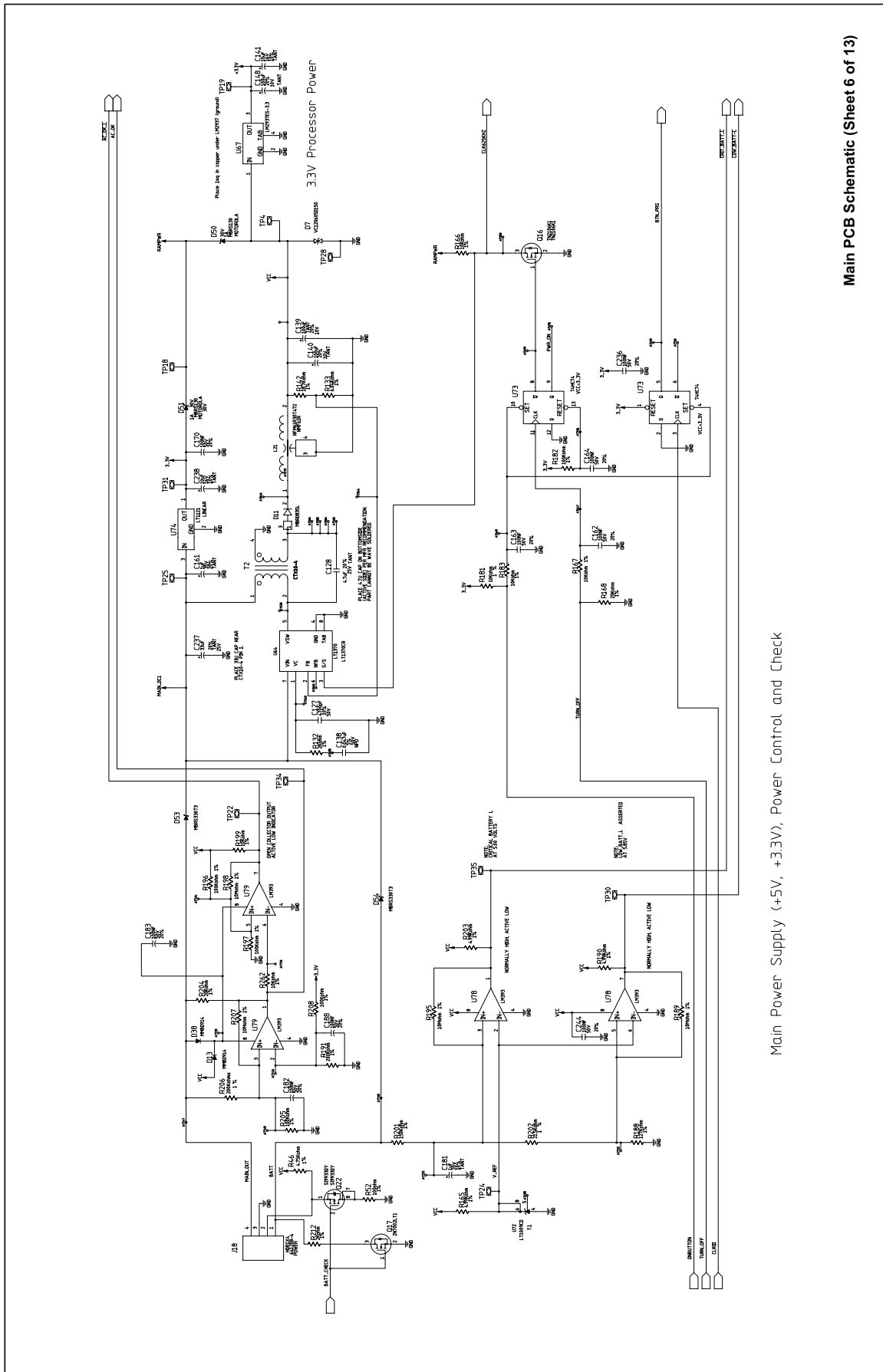

Main PCB Schematic (Sheet 6 of 13)

Main Power Supply (+5V, +3.3V), Power Control and Check

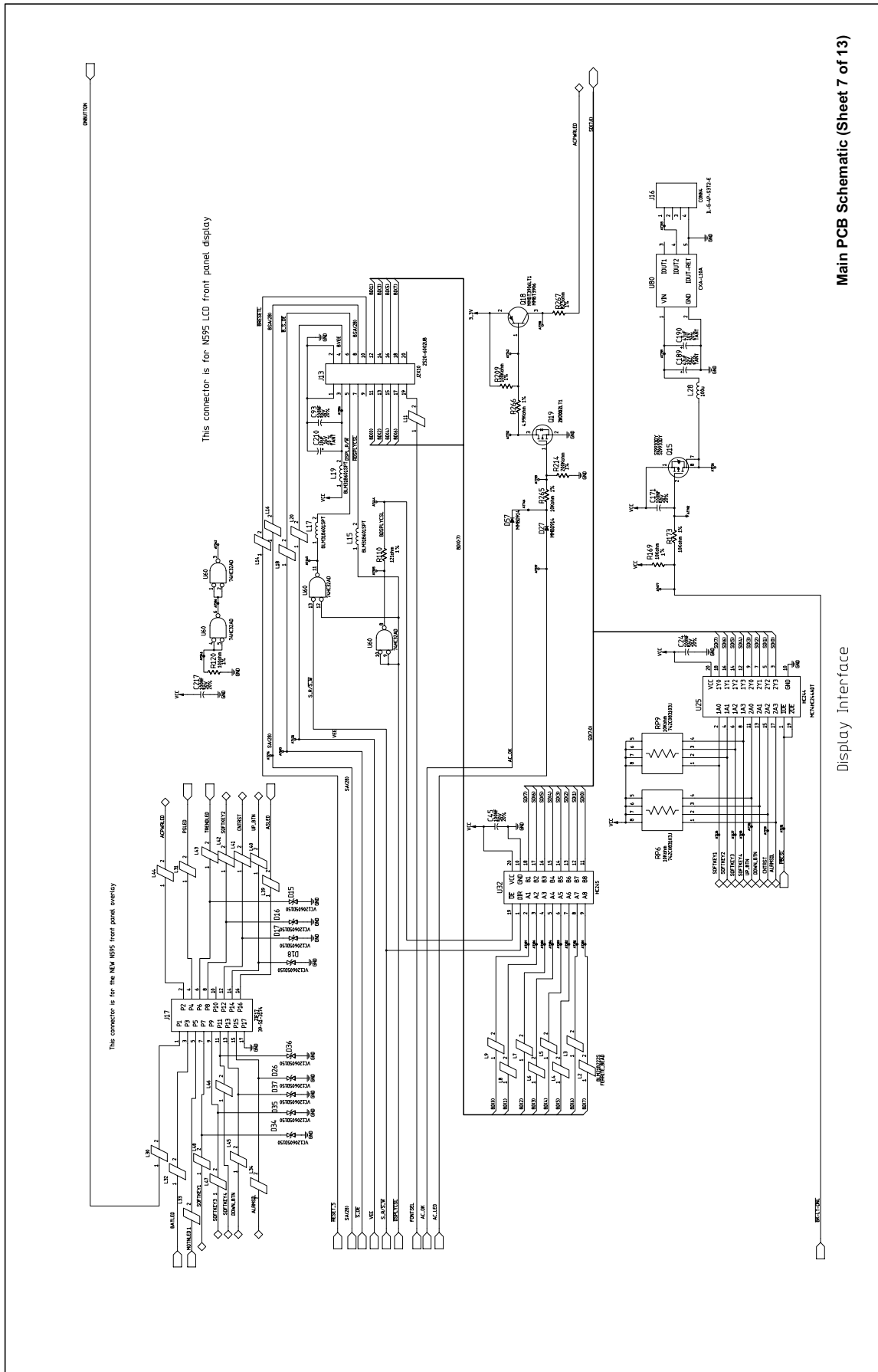

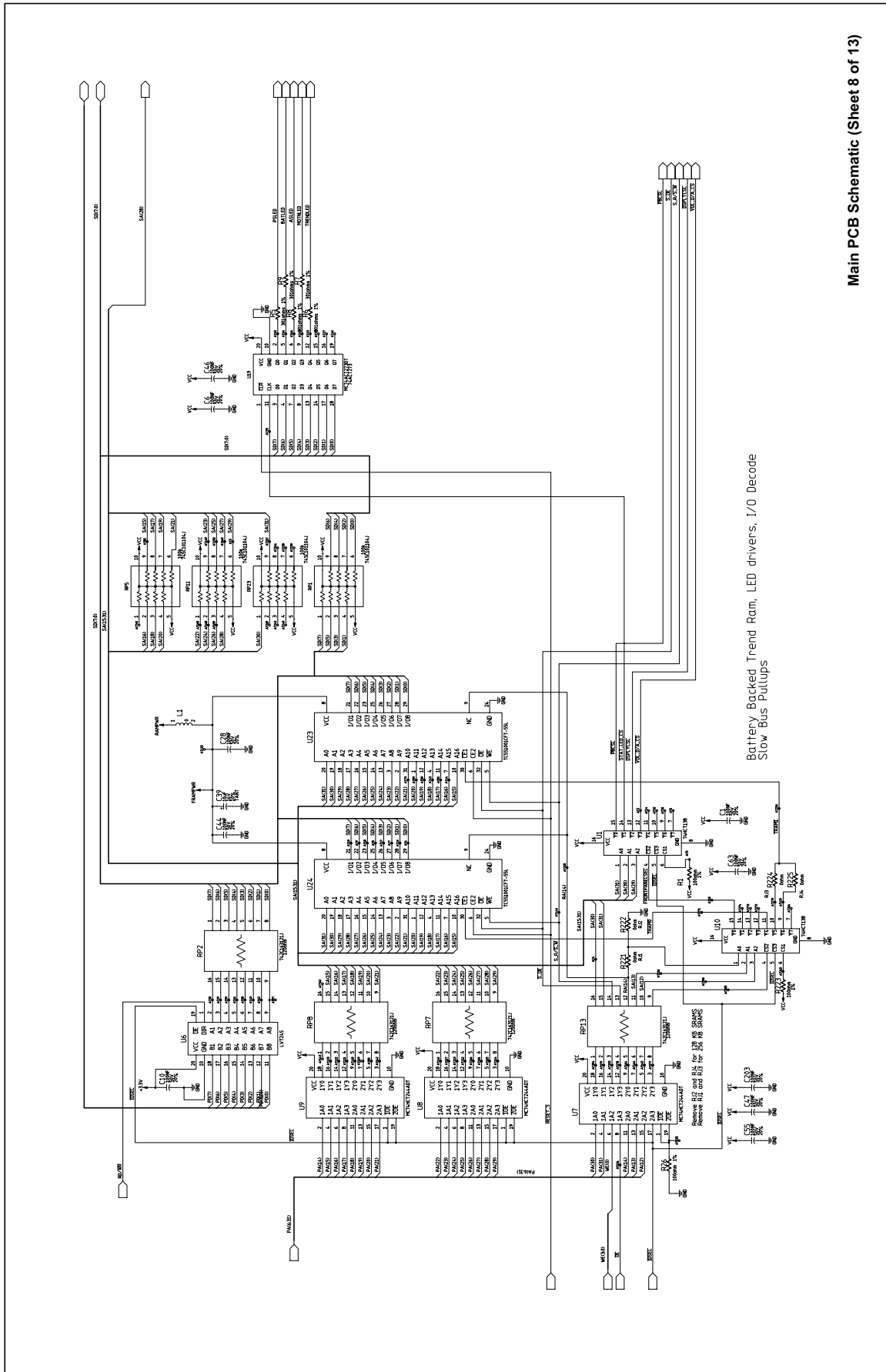

Main PCB Schematic (Sheet 8 of 13)

Battery Backed Trend Rom, LED drivers, I/O Decode
Slow Bus Pullups

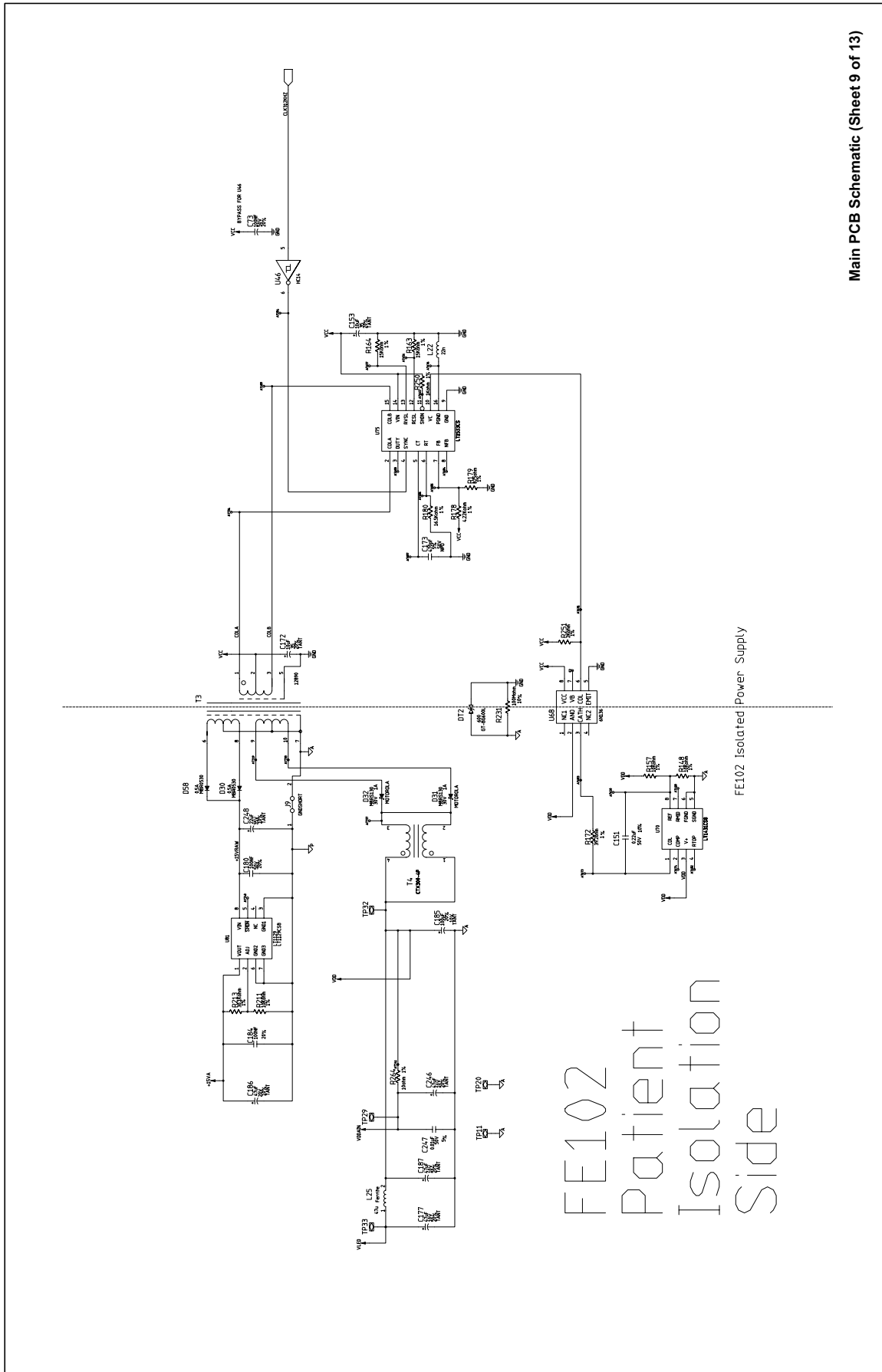

FE102 Patient Isolation Side

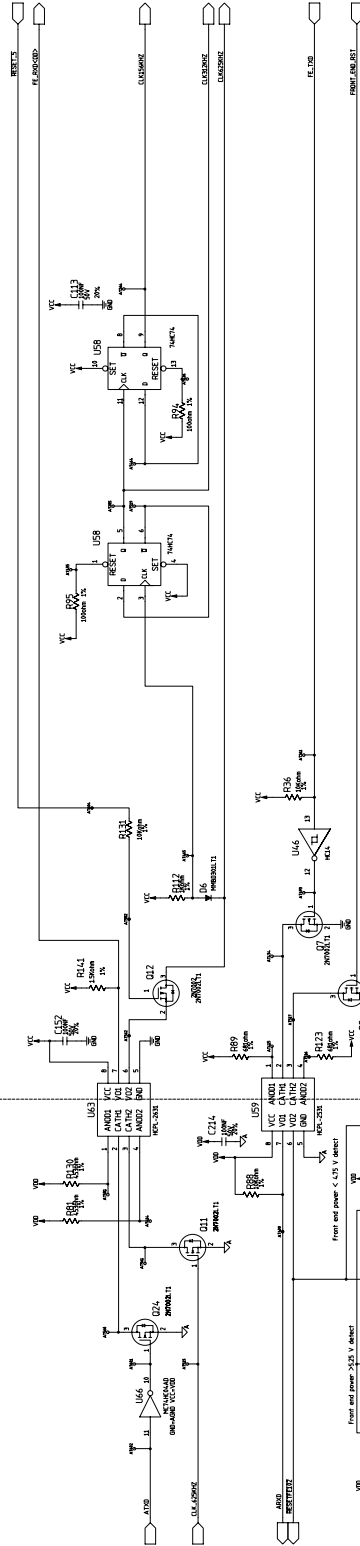
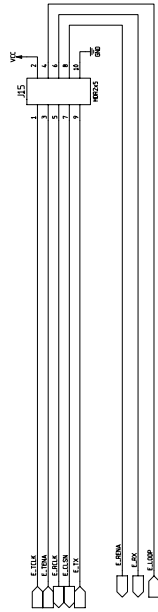

FE102 Serial/Reset Isolated Interface
10 Base T Ethernet Connector

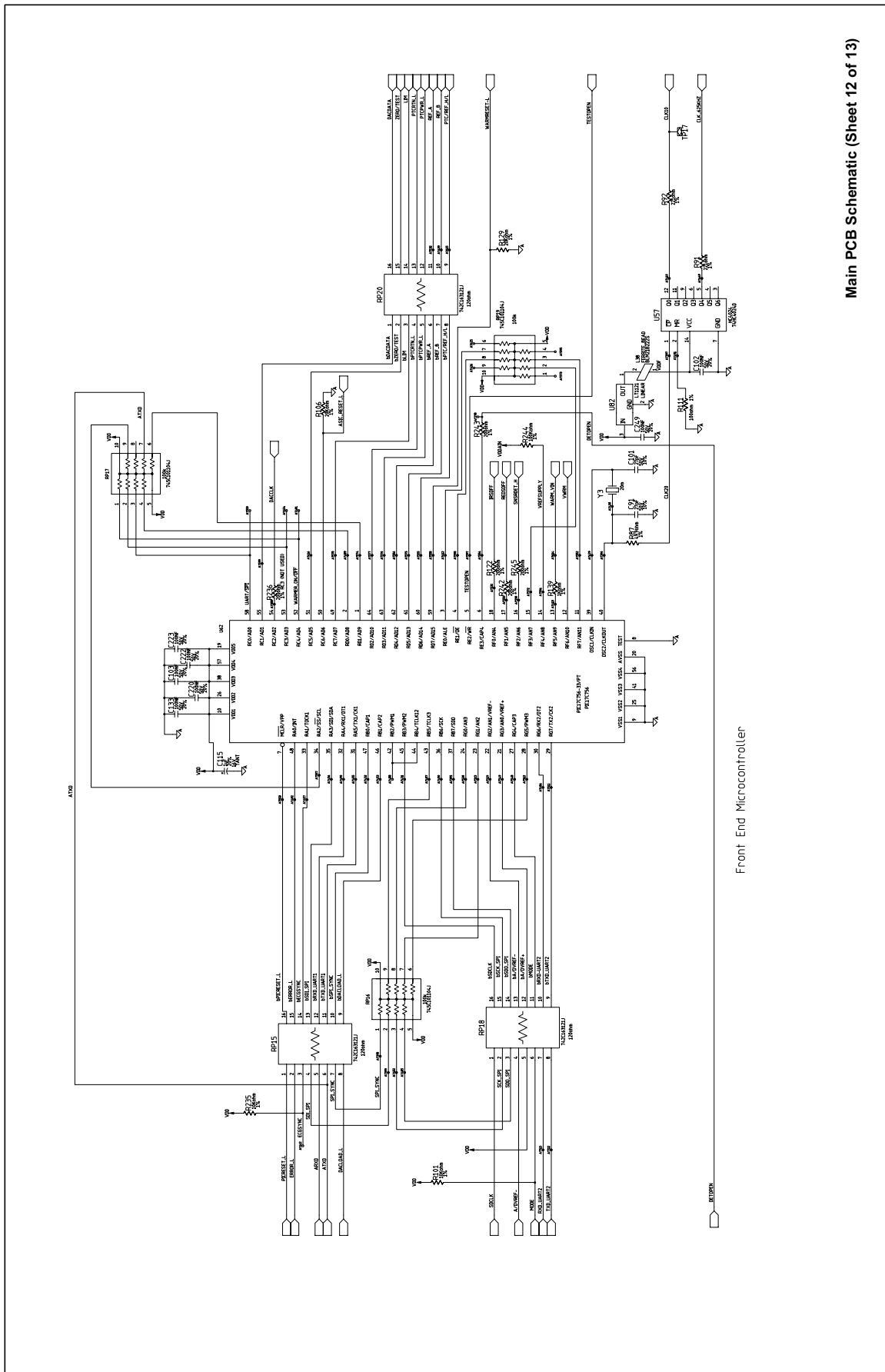

Main PCB Schematic (Sheet 12 of 13)

Front End Microcontroller

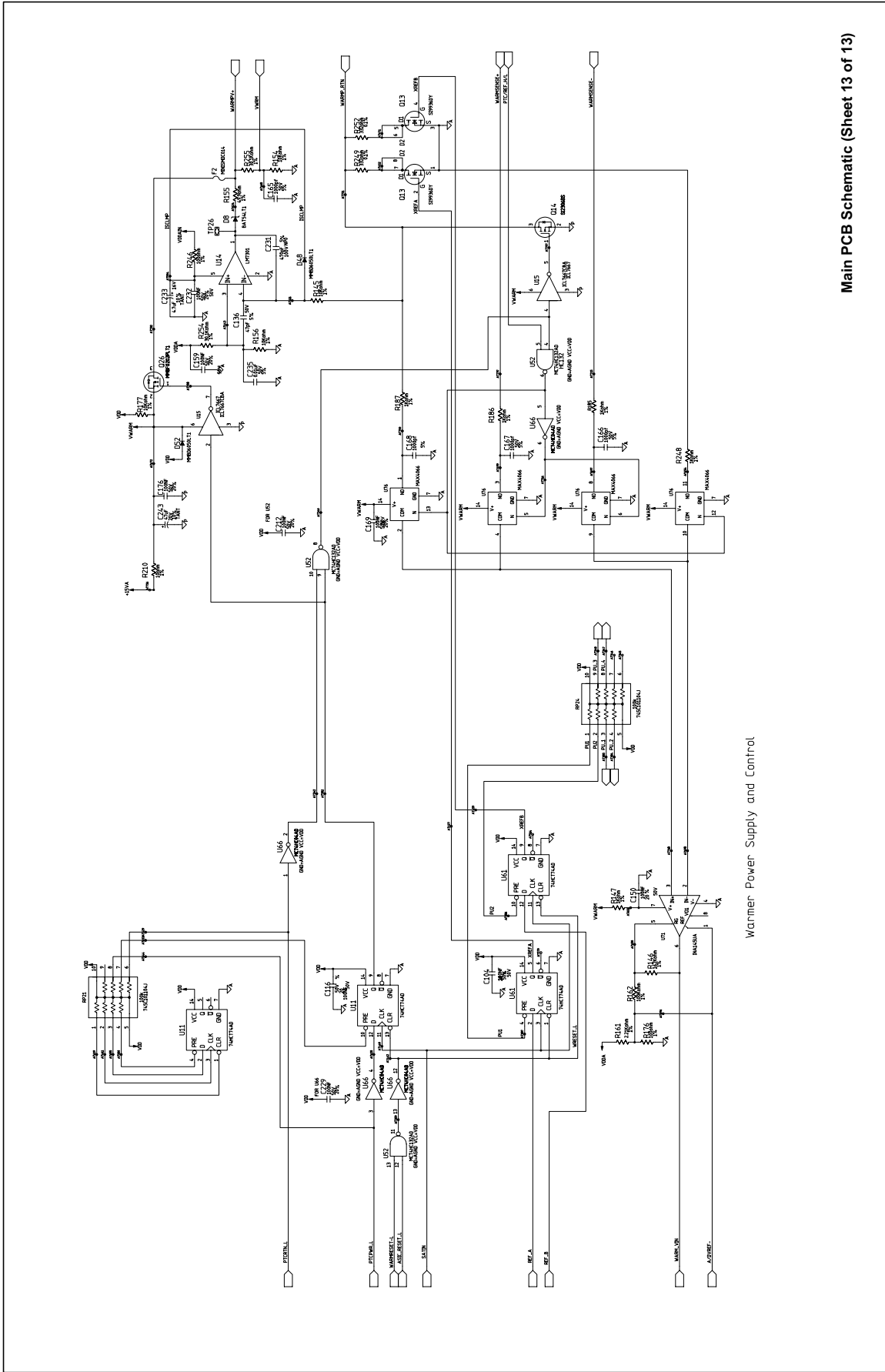

Main PCB Schematic (Sheet 13 of 13)

Warmer Power Supply and Control

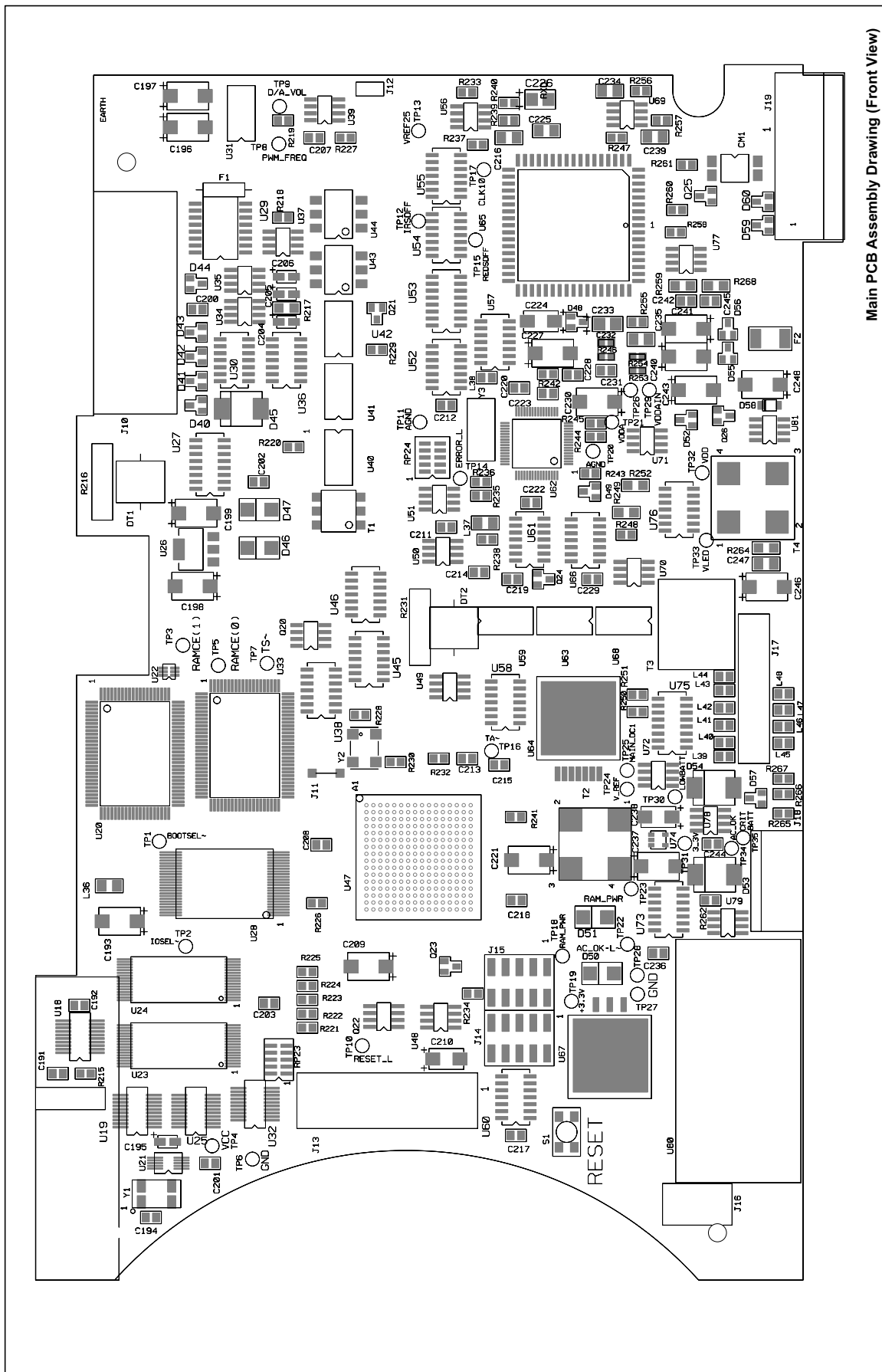

Main PCB Assembly Drawing (Front View)

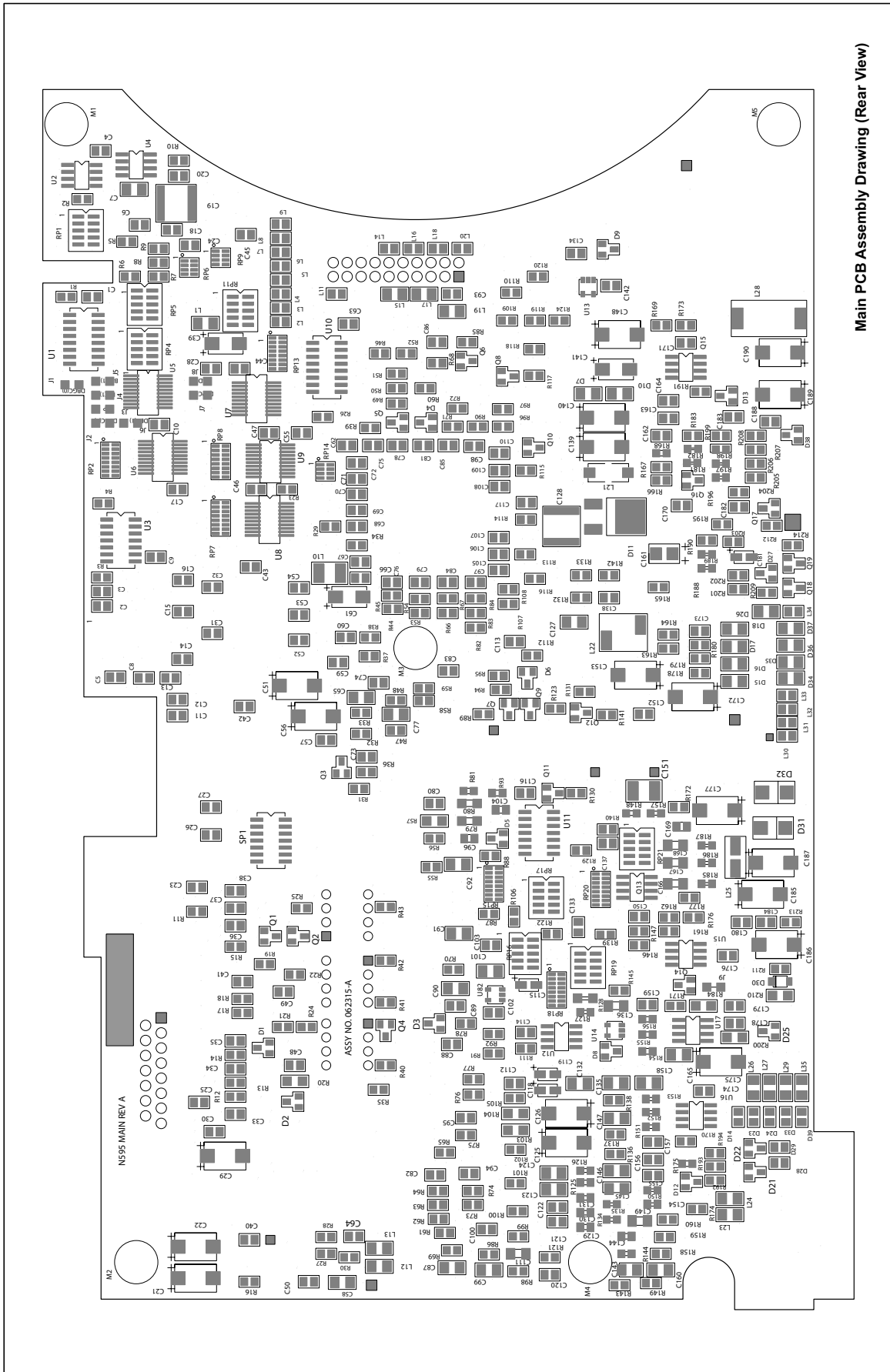

Main PCB Assembly Drawing (Rear View)

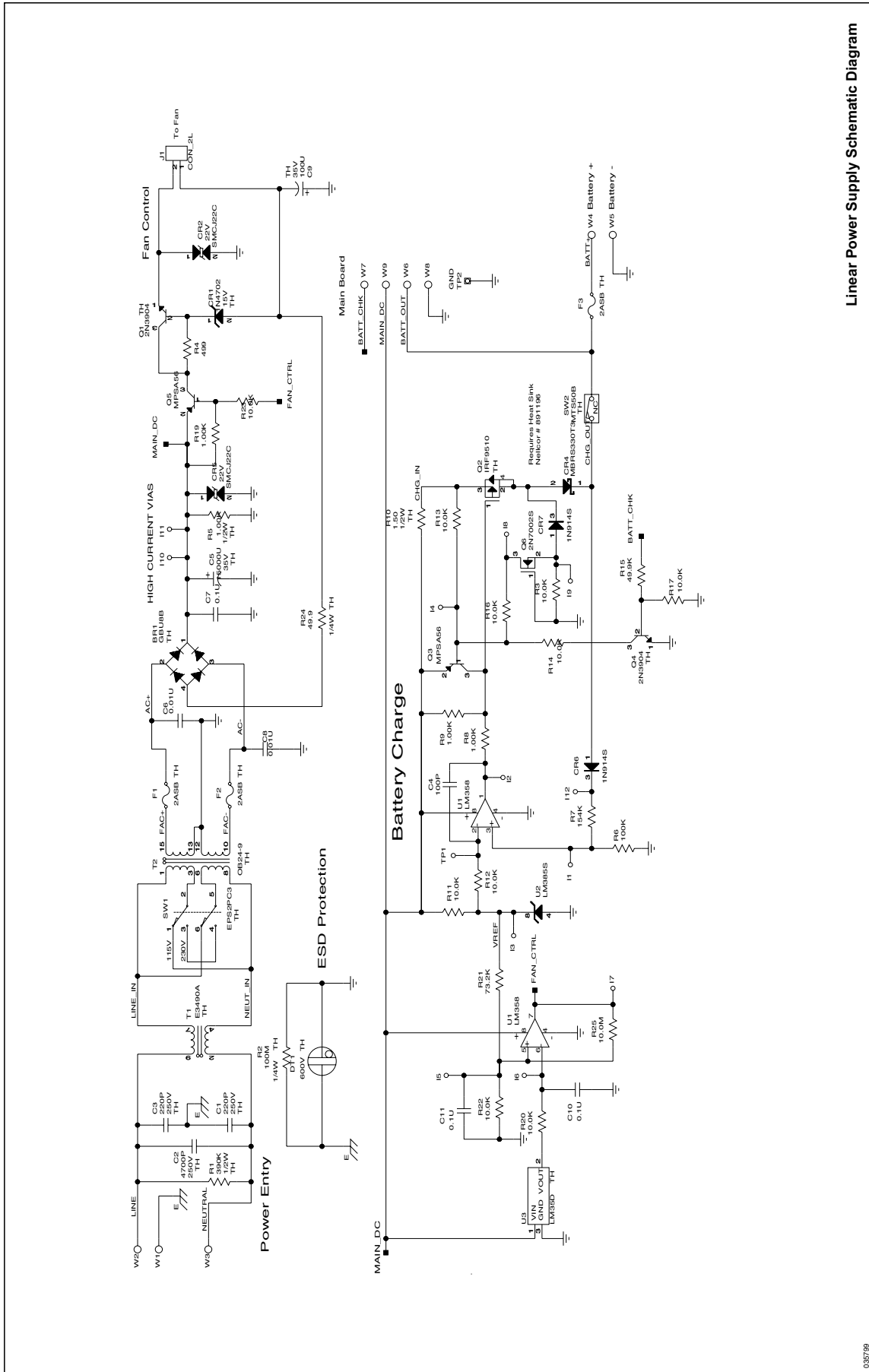

Linear Power Supply Schematic Diagram

0357/99

Index

A

- AC Power Indicator 17
- Accessories on Internet 13
- ADJUST CONTRAST UP/DOWN 142
- Adjusting the Power-On Settings 64, 65, 72, 78
- Adult Default Settings 103, 135
- Adult-Pediatric Patients 72
- Alarm 41
- Alarm Limit Display 78
- Alarm limits, setting 76
- Alarm Management
 - Pulse Rate Delay 41
 - SatSeconds 41
- Alarm Off 91, 135
- Alarm Range Limits 107
- Alarm Silence 111
- Alarm Silence Duration Display 63
- Alarm Silence, AS 91
- Alarm Speaker Replacement 180
- Alarm Volume Control 113
- Alarm Volume display 62
- Analog Output 114
- Analog Voltage Outputs 95
- Anemia 98
- ASCII Mode Printout 88
- Audible Indicators 20

B

- Backlight 61
- Backlight Brightness
 - adjusting 62
- Battery Charge 57, 107
- Battery Fuel Gauge Indicator 55
 - capacities 55
- Battery Replacement 170
- Baud Rate
 - Set 82
- Bedside monitor COMM PORT 84
- Blip Display 27

C

- Cables 36
- Calculated Saturation 40
- Cautions 9
- Cleaning 101
- Clock 69
- Clock Settings Lost 142, 145
- Communication
 - Philips 85
- Confirmation Tone 20

- Connecting an OxiMax Sensor 53
- Contrast 62
- Controls 16
 - Alarm Silence 16
 - Help/Contrast 17
- Cooling Fan Replacement 176
- Current, Leakage
 - (Earth and Enclosure) 37
- Current, Leakage (Earth and Enclosure) 37
- Current, Risk
 - (Patient Applied and Isolation) 38

D

- Data In Sensor 142
- Data port 79
- Data Port Problems 154
- Data Port Setup 82
- Data Type
 - SPO2 142
 - SPO2+BPM 143
- Date 69
- Decimal Points 27, 28
- Default Settings
 - Factory 72
- Defaults Lost 143, 145
- Delete Trends? 143
- Digital Multimeter 105
- Disinfecting 101
- Display
 - Blip 27
 - General Care Format (GCF) 26
 - Plethysmographic (Pleth) 27
 - Real-Time Trend 27
- Display PCB Replacement 176
- DownIid Softkey 134
- Dump Instrument Info 82
- Dysfunctional Hemoglobins 98

E

- Earth Leakage Current Specifications 37
- Electromagnetic Immunity 34
- Electromagnetic Interference 54
- Equipment Needed for Performance Checks 105,
106, 110, 115, 117
- Errlog Softkey 133
- Error Codes 144
 - Non-correctable Failures 146
- Error Messages 141
- Exit Softkey 132
- Exploded View 162



Index

External Fuse Removal 166

F

Factory Default Settings 72

Feature

 OxiMax SPD™ Alert 22

 Pulse Rate Delay Alarm Management 26

 SatSeconds Alarm Management 22

Fractional Saturation 40

Front Panel 16, 29, 30, 32, 35

Front Panel Buttons 16

Front Panel Buttons and Symbols 16

Functional Saturation 40

Fuse Replacement 166

G

Ground Integrity Specification 36

H

Help

 multiple topics 138

I

Icon

 Fast Response Mode 19

 Neonate Alarm Limits 19

 SatSeconds 19

 Saturation Pattern Detection (SPD) 18

Indicator

 AC Power 17

 Battery Fuel Gauge 18

 Data In-Sensor 18

 Interference 17

 Low Battery 17

 Pulse Search 17

Indicator, Fast Response Mode Icon 19

Indicator, Pulse Amplitude 18

Indicators

 AC Power 17

 Battery Fuel Gauge 18

 Data In-Sensor 17, 47, 104, 106, 107, 108, 112, 113,
 115, 119, 127, 130, 131, 132, 134, 165, 167

 Fast Response Mode 19

 Low Battery 17, 56

Instat Softkey 133

L

LED Excitation Test 116

Loss of Pulse 92

Loss of Pulse with Signal Artifact, LM 92

Low Battery 92, 143

Low Battery Indicator 56

M

Main Board PCB Replacement 179

Main Menu 65

Manufacturer's Declaration 32

Measured Saturation 40

menu

 softkey 17

Monitor

 Performance Considerations 97

 Returning 159

Monitor Assembly 169

Monitor Description 13

Monitor Disassembly 166

Monitor Displays Dashes 61

Monitoring Values 19

N

Navigating Menu Options 64

Nurse Call 130

 Relay Pin States 94

 RS-232 Polarity 94

 Using 93

Nurse Call Setup 85

O

Operating

 Altitude 30

 Atmospheric Pressure 30

 Relative Humidity 30

 Temperature 30

Operating the N-600x on Battery Power 55

Operation on Battery Power 106

Operation with a Live Subject 117

Operational Performance Problems 154

OxiMax SPD™ Alerts (SPD) feature 18

OxiMax Technology 29, 30, 36, 47

Oximeter

 Disassembly 167

 Reassembly 169

Oximeter, Description 13

Oximeter, Performance Considerations 97

Oximetry Overview 39

P

Packing for Shipment 184

Index

Param Softkey 132
Parts List 162
Performance Considerations
 Pulse Oximeter 97
 Sensor 98
Performance Tests 106
Performance Verification 97
Physical Characteristics 29, 32, 33
Pleth Display 27
Plethysmographic Waveform 18
Plethysmographic Waveform Display 18
Power Entry Module Replacement 172
Power Problems 152
Power Supply Replacement 174
Power-On Defaults 107
Power-On Self-Test 57, 59, 107
Printing Oximeter Trend Data 86
Problem Categories 141
Protocol
 Printing 86
 Set 82
Pulse Amplitude (blip bar) 18
Pulse Rate Delay 66, 74, 78
Pulse Rate Delay Alarm Management 66
Pulse Rate High Limit Alarm, PR 92
Pulse Rate Low Limit Alarm, PL 92
Pulse Search 92
Pulse Tone Volume Control 114

R

Reading Trends 144
Real-Time Data 88
Real-Time Printout 84
Real-Time Trend Display 27
Rear Panel 21
 Symbols 21
Rear Panel Components 21
Removal
 Alarm Speaker 181
 Battery 170
 Cooling Fan 176
 Display PCB 177
 Main Board PCB 179
 Power Entry Module 172
 Power Supply 174
 Top Case Assembly 183
Removing the Corner Screws 167
Removing the Display PCB 177
Repacking in a Different Carton 185
Repacking in Original Carton 184
Replace

Alarm Speaker 182
Battery 171
Cooling Fan 176
Display PCB 178
Fuse 166
Main Board PCB 180
Power Entry Module 173
Power Supply 175
 Top Case Assembly 183
Replacing the Alarm Speaker 181
Replacing the Cooling Fan 176
Replacing the Display PCB 177
Replacing the Main Board PCB 179
Replacing the Power Entry Module 172
Replacing the Power Supply 174
Replacing the Top Case Assembly 183
Reset Softkey 132
Response Mode 90
Response mode 71
Returning the Monitor 159

S

Safety Analyzer 105
Safety Checks 101
Safety Tests 106
Saturation
 Calculated 40
 Fractional 40
 Functional 40
 Measured 40
Saturation High Limit Alarm 92
Saturation Low Limit Alarm, SL 92
Saturation Pattern Detection 42, 77
Saturation Pattern Detection (SPD) 41
Saturation Pattern Detection (SPD) Feature 66
Save Softkey 132
Screen Contrast 62
SD 92
Searching for a Valid Pulse. 60
Select Softkey 134
Sensor
 Performance Considerations 98
Sensor Disconnect, SD 92
Sensor Disconnected 144
Sensor Off 92
Sensor Power Dissipation 31
Sensor Softkey 132
Sensor Type 144
Service Functions 106
Setting Institutional Defaults 72

Index

Setting SatSeconds Alarm Limit 78

Settings Lost 145

SH 92

softkey

 menu bar 17

Software Version 58

Spare Parts on Internet 13

Specifications

 Compliance 32

 Electrical 32

 Performance 31

 Physical 29

Storage

 Relative Humidity 30

 Temperature 30

Symbols 21

 Data Interface 21

 Data of Manufacture 16, 21

 Equipotential Terminal 21

 See Instructions for Use 21

 Type BF 21

T

Technical Assistance 159

Test No. 1

 BPM 119

Test No. 2

 SpO2 121

Test No. 3

 Modulation Level 122

Test No. 4

 Light 126

Tone

 Alarm Silence Reminder 20

 Confirmation Tone 20

 High Priority Alarm 20

 Invalid Button Press 20

 Low Priority Alarm 20

 Medium Priority Alarm 20

 Piezo Tone 20

 Power-On Self-Test Pass 20

 Pulse Beep 20

 Valid Button Press 20

 Volume Setting Tone 20

Transport

 Altitude 30

 Relative Humidity 30

 Temperature 30

Trend Softkey 133

Troubleshooting, Error Codes 141

Troubleshooting, Low and Critical Battery
 Conditions 156

Troubleshooting, On-Screen Help 137

Troubleshooting, Oximeter Displays Dashes 61, 94

Troubleshooting, Primary Speaker Failure 155

Troubleshooting, Technical Assistance 159

Turning On the Monitor 57

U

User Interface 16

V

Value

 %SpO2 18

 Pulse Rate 18





Nellcor Puritan Bennett LLC
4280 Hacienda Drive
Pleasanton, CA 94588 U.S.A.
Telephone Toll Free 1.800.635.5267

Authorized Representative
Tyco Healthcare UK LTD
154 Fareham Road
Gosport PO13 0AS, U.K.

Rx ONLY

CAUTION: Federal (U.S.A.) law restricts this device to sale by or on the order of a physician. •
ATTENTION: La loi fédérale des États-Unis stipule que ce produit ne peut être vendu que sur
ordre d'un médecin. • PRECAUCIÓN: La ley federal de EE.UU. establece que este producto sólo
puede venderse bajo prescripción médica.



© 2008 Nellcor Puritan Bennett LLC
All rights reserved.

10030881 Rev. B 12-2008



To Purchase, Visit Avobus.com or call [1-800-674-3655](tel:1-800-674-3655)