

FREEDOM MEDICAL

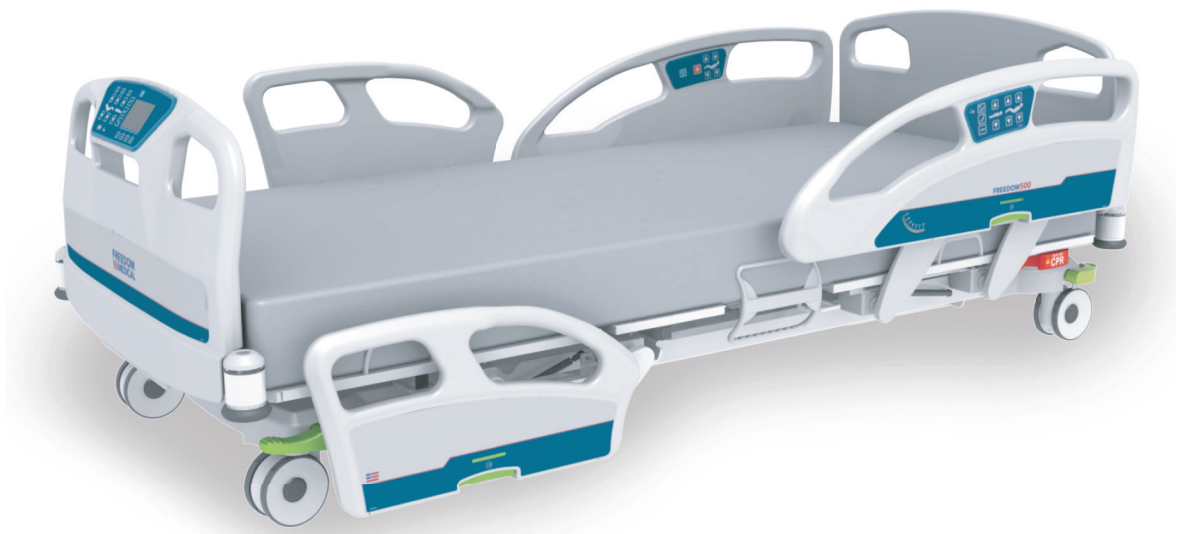

User manual

FREEDOM **MEDICAL**

User manual

All Rights Reserved.

No part of this publication may be reproduced, distributed, or transmitted in any form or by any means, including photocopying, recording, or using electronic or mechanical methods, without the prior written permission of the publisher, except in the case of brief quotations embodied in critical reviews and certain other noncommercial uses permitted by copyright law. For permission request, write to the publisher at the address below.

Use of the masculine form in this document refers to both men and women.

Printed in Canada

TABLE OF CONTENTS

INTRODUCTION	5
Product description	5
Product intended use	5
Contact	5
Product illustration	6
Technical specifications	7
EMC information	9
Symbols and definitions	11
Pictograms and definitions	13
Safety measures	16
Gradation and definition of safety measures	16
Safety measures	16

GETTING STARTED	21
Steps list for set up	21
Zeroing procedure	22

OPERATING INSTRUCTIONS	23
Power up and modes of operation	23
System signals and messages	24
Transporting bed	24
Base, frame and litter	25
Brake, neutral and steer	25
Drainage bag support	25
Accessory and equipment sockets	25
Patient restraint location	26
Bumpers	26
Bumpers with side view lights	26
Power cord support brackets	27
CPR release	27
Nurse call connector	27
Auxiliary power outlets and USB port	28
Communication port	29

Control on frame	29
Nightlight	29
Bed extender	30
Head and foot ends siderails	31
Backrest section angle degree indicator	31
Positioning siderail	31
Patient siderail controls	32
Patient control	33
Caregiver siderail controls	34
Headboard and footboard	35
Built-in transport handles	35
Headboard	35
Integrated pump holder	35
Footboard control	35
Footboard control with display screen	36

ACCESSORIES	49
1" fixed IV pole for 1" socket - FA64508-FMI	49
Left 1" folding IV pole for 1" socket - FA64521-FMI	50
Right 1" folding IV pole for 1" socket - FA64523-FMI	51
Removable pump holder - FA64513-FMI	52
Oxygen bottle holder - FA64505-FMI	53
Patient helper - FA64504-FMI	54
Removable patient control 2 functions - FA64511-FMI	55

PREVENTIVE MAINTENANCE	57
Preventive maintenance annual checklist	58

CLEANING	59
Cleaning	59

Disinfection59

Mattress cleaning and care59

WARRANTY61

 Shipment receipt.....61

 Product return.....61

 Limited warranty61

 Parts and service.....61

INDEX62

INTRODUCTION

This manual includes instructions and information that are necessary for a normal and secure use of the **Freedom500** bed, model FM500. Reading and understanding of instructions and information included in this manual, or other documents supplied with the product, are required prior to usage, or prior to perform maintenance on the equipment.

Product description

The **Freedom500**, model FM500, is an AC-powered medical bed with 4 built-in electric DC actuators. The height and surface contours are adjustable. The bed includes movable and latchable siderails, and control boards. The product offers a range of options and accessories outlined in the manuals, including, but not limited to: integrated scale, bed exit system, integrated bed extender, CPR release handle, fixed or foldable IV poles, patient helper and oxygen bottle holder. The expected life under normal usage and maintenance is 10 years.

Product intended use

The **Freedom500**, model FM500, is designed for use in the following environments: intensive and critical care, acute care, outpatient care, long term care and, recovery or therapeutic areas. The product can be used for patient transportation between bays and procedural rooms. The overall capacity of the bed goes up to 500 lb/227 kg. The bed is designed for the use of one single person and, to be used with a sleep surface. The patient sleep surface can be 80" long or, up to 84" or 90" with the integrated bed extender.

Users are health care providers, bystanders, maintenance staff and the patient. Lockout of siderails controls can limit patient access to functionalities. Only trained personnel or service technician should perform installation or maintenance on the bed.

Contact

The manufacturer can be contacted for any assistance regarding the set up or the use of the bed, its maintenance or to report unexpected events at:

Freedom Medical Inc.
219 Welsh Pool Road
Exton, PA 19341 UNITED STATES
T: (800) 784-8849
bedservice@freedommedical.com

Product illustration

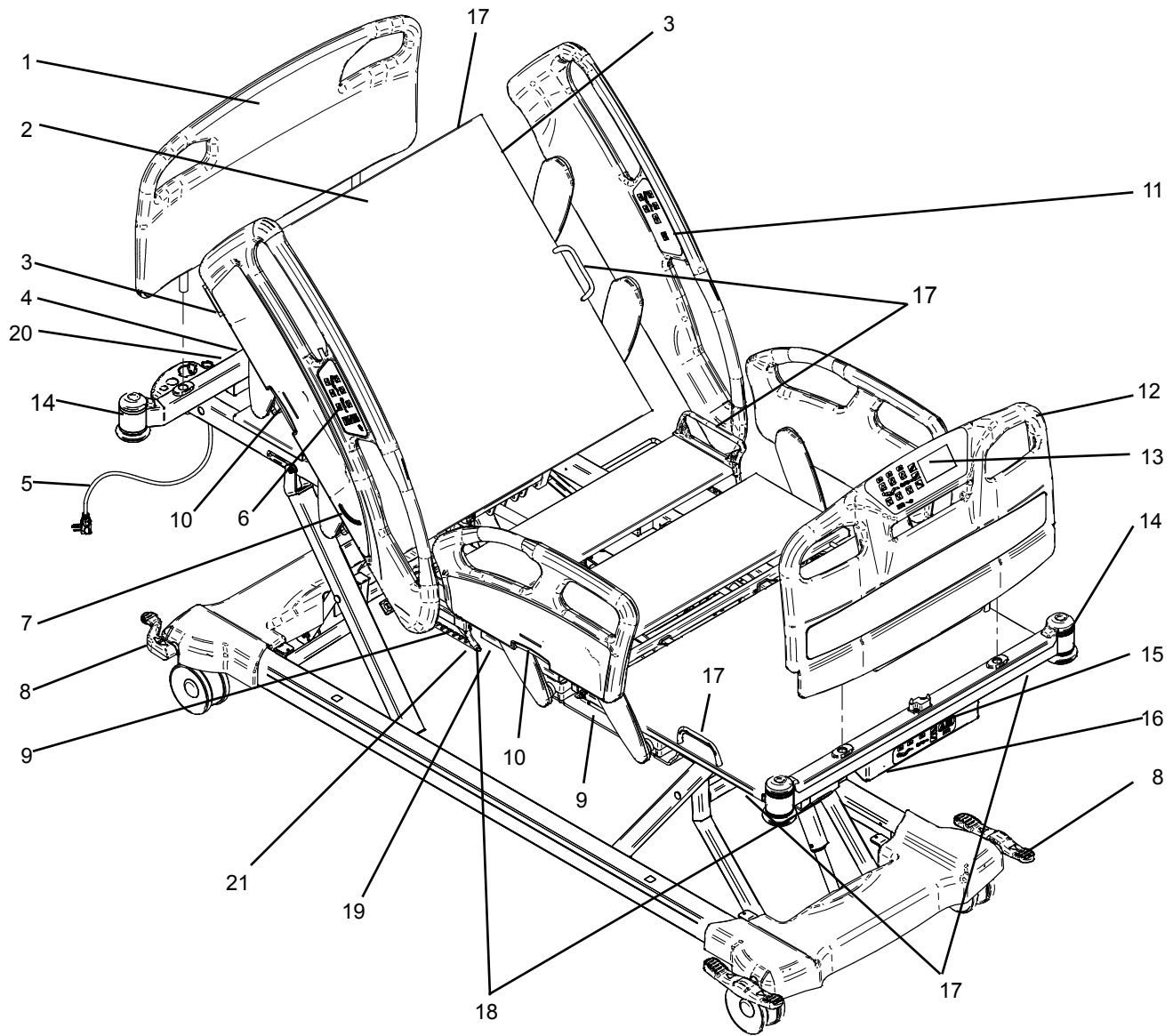

Item	Description	Item	Description
1	Headboard	2	Backrest section
3	CPR release handle	4	Nurse call plug
5	Power cord	6	Siderail control
7	Angle indicator	8	Brake, neutral and steer pedal
9	Drainage bag support	10	Siderail release handle
11	Patient siderail control	12	Footboard
13	Footboard control	14	Bumper
15	Frame control	16	Bed extender handle
17	Patient restraint location	18	Auxiliary power outlets
19	Control box (CB6)	20	Communication port
21	USB connector		

Technical specifications

Weights and dimensions		
Approximative bed weight (based on features)	438 lb	199 kg
Safe working load (including patient, mattress and accessories)	500 lb	227 kg
Maximum mattress weight	44 lb	20 kg
Maximum accessories weight	100 lb	45 kg
Maximum patient weight	356 lb	162 kg
Length including bumpers (80" sleep surface) including extension and bumpers (84"/90" sleep surface)	88" 92" / 98"	224 cm 234 cm / 249 cm
Width with siderails up with siderails down	41.3" 39.25"	105 cm 100 cm
Height * highest with 5" dual casters lowest with 5" dual casters	30" 10"	76.2 cm 25.4 cm
Patient sleep surface width length extended length	35" 80" 84" / 90"	88.9 cm 203.2 cm 213.4 cm / 228.6 cm
Under bed central zone clearance	5"	12.7 cm
Angulations		
Backrest section	0° to 60°	
Thigh section	0° to 30°	
Trendelenburg / reverse Trendelenburg	-16° to +16°	
Recommended mattress		
Foam mattress length extended length width maximum thickness ILD perimeter	80" 84" / 90" 35" 6" 75	203.2 cm 213.4 cm / 228.6 cm 88.9 cm 15.24 cm 75
Specialty or therapeutic mattress		
Use foam mattresses recommendations to orient the choice of a therapeutic mattress. The decision for a therapeutic mattress should be documented by the clinical staff, based on a thorough patient clinical assessment, and should consider the entrapment risk and fall hazards related to the mattress combination.		

* The stroke of the elevation system can be set to adjust the minimum height. Instructions are listed in the Maintenance Manual under Bed height settings.

Environmental conditions		
Use ambient temperature relative humidity atmospheric pressure	50 °F to 104 °F 5 to 95% without condensation 500 to 1060 hPa	10 °C to 40 °C 5 to 95% without condensation 500 to 1060 hPa
Transport and storage ambient temperature relative humidity atmospheric pressure	-40 °F to 158 °F 10% to 100% 500 hPa to 1060 hPa	-40 °C to 70 °C 10% to 100% 500 hPa to 1060 hPa
Maximum altitude	13,123 ft	4000 m
Electrical requirements		
Electrical and mechanical requirements	comply with standards: IEC60601-1, CAN/CSA C22.2 60601-1, UL60601-1, IEC60601-1-2, IEC60601-2-52, CAN/CSA C22.2 60601-2-52	
Degree of protection	IPX4	
Scale accuracy	0.5% with a difference of maximum 1.1 lb / 0.5 kg	
Voltage	120 V AC, 60 Hz	
Amperage (includes power outlet and powered system)	120 V AC: Bed 4.25 A / Auxiliary outlets 5 A / Total = 9.25 A	
Current leakage	<300 micro-amperes	
Battery type	sealed rechargeable lead acid battery 1.2 Ah, 2 x 12 V	
Actuator duty cycle	2 minutes On, 18 minutes Off	
Auxiliary power outlet (with 120V AC model only)	120 V AC / 5 A	
USB type A charger	5 V DC / 3.1 A	

EMC information

Guidance and manufacturer's declaration - emission

The "FM500 Medical Bed" is intended for use in the electromagnetic environment specified below. The customer or user of the "FM500 Medical Bed" should ensure that it is used in such an environment.

Emission test	Compliance	Electromagnetic environment - guidance
RF Emissions CISPR 11	group 1	The "FM500 Medical Bed" uses RF energy only for its internal function. Therefore, its RF emissions are very low and are not likely to cause any interference in nearby electronic equipment.
RF Emissions CISPR 11	class A	The "FM500 Medical Bed" is suitable for use in all establishments, other than domestic, and those directly connected to the public low-voltage power supply network that supplies buildings used for domestic purposes.
Harmonics IEC 61000-3-2	not applicable	
Flicker IEC 61000-3-3	not applicable	

Guidance and manufacturer's declaration – immunity

The "FM500 Medical Bed" is intended for use in the electromagnetic environment specified below. The customer or user of the "FM500 Medical Bed" should ensure that it is use in such an environment.

Immunity test	IEC 60601 test level	compliance level	electromagnetic environment - guidance
ESD IEC 61000-4-2	±6kV Contact ±8kV Air	±6kV Contact ±8kV Air	Floors should be wood, concrete or ceramic tile. If floors are synthetic, the r/h should be at least 30%
EFT IEC 61000-4-4	±2kV Mains ±1kV I/Os	±2kV Mains ±1kV I/Os	Mains power quality should be that of a typical commercial or hospital environment.
Surge IEC 61000-4-5	±1kV Differential ±2kV Common	±1kV Differential ±2kV Common	Mains power quality should be that of a typical commercial or hospital environment.
Voltage Dips/Dropout IEC 61000-4-11	>95% Dip for 0.5 Cycle 60% Dip for 5 Cycles 30% Dip for 25 Cycles >95% Dip for 5 Seconds	>95% Dip for 0.5 Cycle 60% Dip for 5 Cycles 30% Dip for 25 Cycles >95% Dip for 5 Seconds	Mains power quality should be that of a typical commercial or hospital environment. If the user of the "FM500 Medical Bed" requires continued operation during power mains interruptions, it is recommended that the "FM500 Medical Bed" be powered from an uninterruptible power supply or battery.
Power Frequency 50/60Hz Magnetic Field IEC 61000-4-8	3A/m	3A/m	Power frequency magnetic fields should be that of a typical commercial or hospital environment.

Guidance and manufacturer's declaration - immunity

The "FM500 Medical Bed" is intended for use in the electromagnetic environment specified below. The customer or user of the "FM500 Medical Bed" should ensure that it is used in such an environment.

Immunity test	IEC 60601 test level	Compliance level	Electromagnetic environment - guidance
Conducted RF IEC 61000-4-6	3 Vrms 150 kHz to 80 MHz	(V1)=3Vrms	Portable and mobile communications equipment should be separated from the "FM500 Medical Bed" by no less than the distances calculated/listed below: $D=(3.5/\sqrt{V1})(\sqrt{P})$ 150kHz to 80MHz $D=(3.5/E1)(\sqrt{P})$ 80 to 800 MHz $D=(7/E1)(\sqrt{P})$ 800 MHz to 2.5 GHz where P is the max power in watts and D is the recommended separation distance in meters. Field strengths from fixed transmitters, as determined by an electromagnetic site survey, should be less than the compliance levels (V1 and E1). Interference may occur in the vicinity of equipment containing a transmitter.
Radiated RF IEC 61000-4-3	3 V/m 80 MHz to 2.5 GHz	(E1)=3V/m	

Recommended separations distances for the "FM500 medical bed"

The "FM500 Medical Bed" is intended for use in the electromagnetic environment in which radiated disturbances are controlled. The customer or user of the "FM500 Medical Bed" can help prevent electromagnetic interference by maintaining a minimum distance between portable and mobile RF Communications Equipment and the "FM500 Medical Bed" as recommended below, according to the maximum output power of the communications equipment.

Max output power (Watts)	Separation (m) 150kHz to 80MHz	Separation (m) 80 to 800MHz	Separation (m) 800MHz to 2.5GHz
	$D=(3.5/\sqrt{V1})(\sqrt{P})$	$D=(3.5/E1)(\sqrt{P})$	$D=(7/E1)(\sqrt{P})$
0.01	0.116667	0.116667	0.233333
0.1	0.368932	0.368932	0.737865
1	1.166667	1.166667	2.333333
10	3.689324	3.689324	7.378648
100	11.66667	11.66667	23.33333

Symbols and definitions

Different symbols are used on the product and in this manual. Their purpose is to inform the user on functional details or on safety related measures.



Indicates the date of manufacture



Indicates the need for the user to consult the instructions for use for cautionary information such as warnings and precautions that cannot be presented on the medical device itself



Indicates the manufacturer's catalogue number so that the medical device can be identified

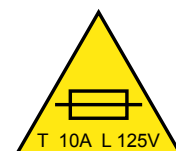

Indicates a fuse of 10 amperes / 125 volts

IPX4

Indicates the level of protection against liquid splash

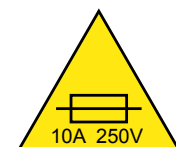

Indicates a fuse of 10 amperes / 250 volts



Indicates a Type B applied part complying with the specified requirements of this standard to provide protection against electric shock, particularly regarding allowable patient leakage current and patient auxiliary current



Indicates a breaker of 5 amperes / 250 volts



Indicates a terminal which is intended for connection to an external conductor for protection against electric shock in case of a fault, or the terminal of protective earth (ground) electrode



Indicates a warning of foot crushing hazard



Indicates that on the rating plate, the equipment is suitable for alternating current only; to relevant terminals



Indicates a warning of hand crushing hazard

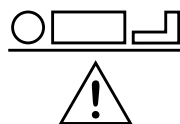

Indicates the patient maximum weight for a safe use of the equipment

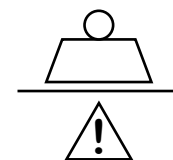

Indicates the total maximum charge for a safe use of equipment



Indicates the need for the user to consult instructions for use



Indicates the need for the user to follow instructions for use



Indicates a general mandatory action

ETL CLASSIFIED



Indicates that the equipment has been independently tested and meets the applicable published safety standard

Intertek



Indicates that when disposed, the equipment must be collected separately in accordance with the European Directive 2002/96 relative to waste electrical and electronic equipment (WEEE)

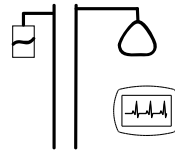

Indicates the accessories weight

Pictograms and definitions

Different pictograms are used on the product and in this manual. Their purpose is to facilitate the reading and the understanding of the different functionalities to the user. If bed is equipped with screen, additional pictograms may be displayed in different menus. Refer to [Footboard control](#) (page 35) section if required.



Button for elevation of section illustrated below the button



Button for a 30 degrees angle positioning of the Backrest section



Button for lowering of section illustrated over the button



Button for chair positioning



Illustration indicating possible activation of Hi-Lo per use of button located over or below the pictogram



Button for Nurse Call



Illustration indicating possible activation of Backrest section AND/OR the Thigh Section per use of one or both buttons located over or below the pictogram



Button for activation or deactivation of controls backlight



Button for Trendelenburg positioning



Illustration with LED indicator indicating power supply



Button for reverse Trendelenburg positioning



Illustration with LED indicator for battery supply and battery charge level indication

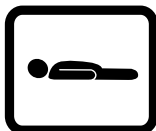

Button for patient sleep surface flat positioning



Button with LED indicator for lock (On), unlock (Off), of patient and siderail motion control



Button for the vascular foot positioning

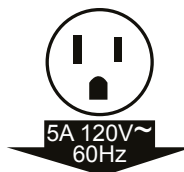

Illustration indicating location of auxiliary outlets

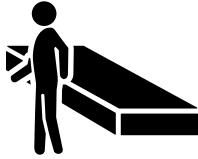

Illustration indicating selection of/ activated bed exit control level of detection for Detection 1 - OUT-OF-BED



Button with LED indicator for activation/deactivation, of bed exit control system



Illustration indicating selection of/ activated bed exit control level of detection for Detection 2 - BED EXITING

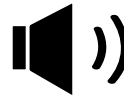

Illustration for selection of audio signal level



Illustration indicating selection of/ activated bed exit control level of detection for Detection 3 - MOVEMENT



Illustration indicating the recommended mattress thickness



Illustration indicating patient is subject to falls



Illustration indicating the recommended mattress width



Illustration indicating that patient has one or more allergies



Illustration for the Inform system settings or usage



Illustration indicating a patient subject to bedsores



Illustration indicating necessity to monitor blood sugar level



Illustration indicating patient is subject to confusion



Illustration indicating interdiction to drink liquids



Illustration indicating that two person are required to move the patient

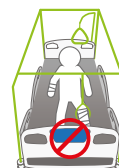

Illustration indicating interdiction to change bed configuration



Illustration indicating the necessity to monitor blood pressure



Illustration indicating that no visitors are allowed



Illustration indicating location for communication port

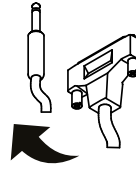

Illustration indicating location for nurse call connector

Safety measures

Terms DANGER, WARNING, ATTENTION and IMPORTANT are used in this manual to indicate important measures to take for use or maintenance of the equipment. The gradation, the definitions and safety measures shall be carefully reviewed and understood before use.

Gradation and definition of safety measures

DANGER

Indicates an imminent hazardous situation, which if not avoided, will result in serious injury or death.

WARNING

Indicates a potentially dangerous situation, which if not avoided, could result in a moderate to a severe injury or death.

ATTENTION

Indicates a potentially dangerous situation, which if not avoided, could result in a minor to moderate injury or, in damages to the product or to the environment.

IMPORTANT

Indicates additional precisions on user or maintenance instructions.

Safety measures

IMPORTANT

Reading and understanding of safety measures included in this manual are required prior to set up, usage and/or maintenance of the bed. Users shall be trained on product usage and knowledgeable of hazards associated with usage of electric beds.

DANGER

- **ELECTRIC SHOCK HAZARD.** Always unplug the power cord and, if applicable, unplug the batteries harness before performing maintenance and/or repairs on the bed. If not avoided, situation could result in severe injury or death.
- **ELECTRIC SHOCK HAZARD.** Use of defibrillator with this product may cause damages to product and/or result in severe injury or death. The metallic components of this medical bed can accumulate or channel defibrillator charges and discharge it to any person in close proximity.
- **POSSIBLE FIRE HAZARD.** When using oxygen-administering equipment other than the nasal or mask type, lock the push button controls at the foot end and in the display screen motion controls (if applicable). If not avoided, sparks could occur into actuators and situation could result severe injury or death.
- **DO NOT** use the auxiliary power outlets for powering a life-sustaining device.

**WARNING**

- Grounding reliability can be achieved only when the bed is connected to a supply mains with protective ground or to a hospital grade outlet that is protectively grounded.
- To avoid risk of electric shock hazard, bed must only be connected to a supply mains with protective ground or to a hospital grade outlet that is protectively grounded.
- This bed is designed and intended for usage with a maximum total charge of 500 lb/227 kg, including patient, mattress and accessories. If not avoided, bed functionalities may not work properly and permanent damages to bed may occur.
- This bed is not designed nor intended to be used with infants. If not avoided, situation could become hazardous and prevention of patient fall or patient entrapment cannot be ensured.
- The bed exit detection system must be used with patients with minimum weight of 50 lb/22.6 kg. If not avoided, the bed exit detection system may not detect all movements and the functionality could be affected.
- Always ensure that bed is clear of interference with other equipment, parts of patient's body or other person prior to any operation of the bed. If not avoided, moderated to severe injuries and/or permanent damages to bed or environment could occur.
- Always ensure proper clearance under the bed prior to use hoists, or other equipment, that slide under the bed. If not avoided, moderated to severe injuries and/or permanent damages to bed or environment could occur.
- Severe patient injuries could result of an improper usage of restraint straps. Healthcare professionals shall ensure proper restraint straps usage, location and adjustment.
- Severe patient injuries could result of bed movement functions operation if patient restraint straps are in usage. Do not operate bed if patient restraint straps are in usage.
- If siderails are used by patient as a grip handle, they shall be used with caution. Abusive usage could result in bed tipping over and could result in moderate to severe injuries and damages to product and/or environment.
- Siderails are not designed nor intended for patient restraint. If not avoided, situation could result in patient injury.
- Do not use siderails to move the bed. If not avoided, situation could result in mechanical damages, which could lead to patient fall. Use headboard or footboard to move the bed.
- CPR release usage shall be restricted to emergencies. To avoid injuries or product damages, ensure total clearance around product prior to usage.
- To reduce risk of fall and injury when patient is unattended, keep patient sleep surface to the lowest position and siderails raised.
- Always ensure the mattress used on bed complies with specifications of recommended mattresses. If not, situation could become hazardous for patient fall or patient entrapment.
- Verification and maintenance of bed shall be performed by qualified and trained personnel. Electrical or electronic misconnection could result in shock or fire hazards.

- If electrical equipment is connected to the auxiliary outlet or USB port, ensure that any electrical device introduced within the patient vicinity is not causing electrical interferences. The connected electrical equipment could result in power leads or radiation emitting devices closer to the patient (ex: computer charger, mobile phone) and their interference shall be managed to avoid biased diagnostics (ex: ECG monitors) or limited treatment efficiency (ex: pacemakers).
- The use of accessories, transducers and cables other than those specified, with the exception of transducers and cables sold by the manufacturer of the medical electrical equipment or medical electrical system as replacement parts for internal components, may result in increased emissions or decreased immunity of the medical electrical equipment or medical electrical system.
- The medical electrical equipment or medical electrical system should not be used adjacent to or stacked with other equipment and that if adjacent or stacked use is necessary, the medical electrical equipment or medical electrical system should be observed to verify normal operation in the configuration in which it will be used.



ATTENTION

- Patient monitoring and patient-authorized bed functionalities are the responsibility of the facility.
- Always ensure to unplug power cord from power outlet prior to move bed. If situation is not avoided, damages to bed and/or to environment could occur.
- Always ensure of power cord proper condition prior to plug it into power outlet.
- Always ensure that when routing cables from other equipment or hoists in the bed, precautions are taken to avoid them to be pinched between parts of the bed.
- Connecting electrical equipment to the auxiliary outlet effectively leads to creating a medical electrical system, and can result in a reduced level of safety.
- Always ensure proper product clearance at all time in order to reach all the different device controls, boards, accessories and electrical connections. In case of emergency, these systems should be easily reachable to ensure timely procedure.
- Always ensure to unplug any device from the auxiliary outlet prior to move bed. If situation is not avoided, damages to bed and/or to environment could occur.
- Always unplug battery harness if bed is intended to be stored for 3 months or longer. If not avoided, situation could result in an accelerated deterioration of the batteries.
- Bed, parts and accessories are not designed for a cleaning with usage of a hose, steam or ultrasounds. Do not immerse any part of the bed. If not avoided, situation could result in permanent damages to bed.
- This bed is not designed nor intended for a magnetic resonance imaging use. Use in intended environments only.
- No modification to this equipment is allowed unless it is first approved by the manufacturer, performed by trained personnel, and then inspected and tested to ensure its continued safety.
- If a replacement is required, always use original new parts supplied by manufacturer. If not avoided, situation could generate adverse effects and could affect the warranty.

- The organization responsible for usage and for maintenance of a medical electrical system shall ensure that the equipments connected on the auxiliary power outlet are conforming to the electrical specifications like, but not limited to, power drawn, leakage currents or electromagnetic compliance for electromedical systems (IEC60601-1; 2005).

IMPORTANT

Words LEFT and RIGHT used in this manual refer to the left and right sides of the patient while laying on his back.

GETTING STARTED

IMPORTANT

Bed must be properly installed and verified prior to be put in service. Refer to the list below to ensure proper set up.

Steps list for set up

1. Perform a complete visual inspection of the bed. Contact **Freedom Medical Inc.** or local representative if there are any damages or missing item.
2. To prevent permanent damages, ensure bed has reached [environmental conditions for use](#) (page 8) prior to plug it. Refer to the section of [technical specifications](#) (page 7).
3. Apply brakes. Try to move the bed to verify if brakes are engaged. Repeat to test all brake pedals.
4. Install headboard and footboard. Ensure not to mix boards with other units, if setting up more than one bed. Boards configuration could be different and a mix up could result in inoperative functions.
5. If applicable, install accessories. Refer to [Accessories](#) section (page 49).
6. Plug the bed power cord in a hospital grade power outlet. If applicable, store the remaining of the power cord on the power cord support brackets while keeping clearance in prevision for movement from elevation system. A power supply of 4 to 5 hours is needed to allow bed to reset its settings according to environmental conditions of use and to reach a minimum battery charge. In case of complete discharge, bed may need a 24-hour plugging for a full recharge.
7. On the footboard, ensure that the green LED beside the power cord pictogram is ON. Test each control of the footboard. If applicable, ensure that the screen does not warn of a required maintenance, and set preferences.
8. If a "bip" can be heard and no functions are working, it is possible that the setting's reset, according to the environmental conditions of use, was not completed and that the bed detects a too high environmental temperature variation. Let the bed rest in order for the settings to reset properly.
9. Raise every siderail and ensure they each lock properly in upper position. Release and lower each siderail to ensure of smooth motion.
10. Test each control press button for both head siderails.
11. Ensure functionality of each LED light and audio indicators.
12. Test each control of the back-up control on frame.
13. Test the CPR emergency release handle: raise backrest section and pull CPR handle located on one side of backrest section. Bed will return in flat position. Repeat to test second handle.
14. Test the integrated scale system for proper operation and ensure it is within specification.
15. Connect the nurse call communication system to the bed nurse call connector. Test for proper operation.
16. Verify following features for proper operation: bed extender, auxiliary power outlets and USB port, nightlights, etc.
17. Perform a zero procedure on the bed after all equipment has been installed.

Zeroing procedure

ATTENTION

- Patient must be out of bed.

Cancellation of zeroing process can be done at any time by pressing the "Cancel" button.

Procedure:

1. Bed is powered up. Ensure sleep surface is completely flat and put the bed elevation system at intended height of use. Apply the brakes.
2. From the display screen on the footboard, enter the Scale menu.
3. Press the "zero" button.
4. Password may be required, enter password.
5. Follow the instructions; patient out of bed, install all required equipments, accessories and mattress.
6. Press ZERO button on display screen again. **Do not touch bed while this is in progress.**
7. Zero is successful if a confirmation message appears and the display screen returns to "Scale" menu.
8. If failure occurs, a message appears to indicate that weight is unstable. Display screen will stay in Zero menu.
9. Ensure there is no interference and start over the procedure.

OPERATING INSTRUCTIONS

IMPORTANT

Read and understand all information covered in this manual before operating the equipment. Users shall be knowledgeable about inherent hazards related to use of electric beds.

Power up and modes of operation

If a power failure occurs, bed will automatically fall in sleep mode and initiate the battery-powered mode.

If the bed operates on batteries, the patient and caregiver controls for bed-motion will remain functional. A lockout on siderail motion control will be saved.

Powered mode:	Powered mode is activated if bed is power supplied or if power returns after failure. All bed functionalities will operate if bed is power supplied. If battery level requires recharge, the battery pictogram with integrated LED will be flashing green.
---------------	--

Screen sleep mode: Activated after 1 minute of bed inactivity; screen brightness will decrease by half. After 2 minutes of bed inactivity, screen will turn off completely and get in sleep mode. If a screen saver is activated, the information will be displayed while in sleep mode. To get out of sleep mode, press on any button associated with the screen.

Battery powered mode:	Battery powered mode is activated if power failure occurs or if bed power cord is unplugged from wall outlet ; it will first fall in sleep mode. Under the battery-powered mode, an armed bed exit control system will send a signal to the nurse call communication system to inform of battery-powered mode; no local sound signal will be heard. Only the UP/DOWN press buttons, the Trendelenburg and reverse Trendelenburg press buttons for bed motion and the motion lockout will operate.
-----------------------	---

Will not operate: one button positioning, bed exit control or scale system, and display screen. The battery charge level is accessible on the footboard control or on the back-up control on frame.

Low level audible signal: Two LED sections of battery pictogram lighted. When a movement function is activated, functionalities will operate with a low battery level audible signal.

Recharge audible signal: One red LED section of battery pictogram lighted. When a movement function is activated, functionalities will not operate and there will be a constant audible signal.

System signals and messages

The hospital bed FM500 can issue a signal or a message to inform the user that an action is required. It can be visual and/or audible and/or textual.

Visual sign

A visual signal may take the form of flashing LEDs on the membrane of the footboard. A reset or a component replacement may be required; contact the maintenance department for verification.

If the LED for bed power supply, located on the siderails, is flashing when using a one-touch button, it indicates that the bed must be plugged into the main power supply for usage of this feature.

Audible sign

An audible signal can be caused by an insufficient level of battery charge; plug the bed into the main power supply.

An audible signal can be issued from the control box situated under the seat section. A verification of connections, a calibration or a component replacement may be required; contact the maintenance department for verification.

IMPORTANT

If the audible signal is emitted from the buzzer situated in the electrical box at head end of the bed or, through the nurse call system, it indicates that the bed exit system has detected a movement from the patient or, that the patient has pressed the nurse call button. In both cases, the patient requires assistance from a caregiver.

Textual error message

A textual error message can be displayed on the screen located on the footboard. A reset, a verification of connections, a calibration or a component replacement may be required; contact the maintenance department for verification.

Transporting bed

Unplug cables from wall outlets (power cord, nurse call, etc.), store power cord on support brackets and adjust height of bed for an ergonomic posture before initiating bed transportation. If transporting bed with a patient in the bed, lock siderails up and adjust height of bed at the lowest height while as ergonomic as possible. Use the built-in pull and push handles located in the corners of the headboard and footboard. Do not use siderails to move the bed. If not avoided, situation could result in mechanical damages, which could lead to patient fall.

BASE, FRAME AND LITTER

IMPORTANT

The bed is equipped with base covers at head and foot ends of the bed. Base covers must be kept in place while bed is in use to preserve electrical and mechanical components.

Brake, neutral and steer

Brake, neutral and steer can be activated manually with one of the 4 pedals located at one of each corner of the bed.

Engage brakes:

1. To engage, press down completely one of the 4 pedals on the red arrow side.
2. Ensure brakes are engaged.
3. To disengage brakes at head end, lift one of the pedals once to put in neutral position, lift fully up for steer position. To disengage brakes at foot end, lightly press down one of the pedals on the steer side to put in neutral position. Completely press down for steering.

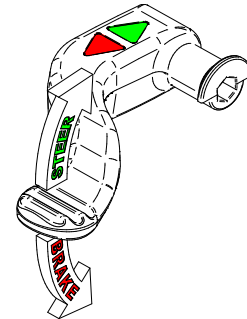

HEAD END PEDAL

Neutral positioning:

1. Bed is in a neutral positioning when pedals at head and foot ends are in flat position.
2. Press down pedal on required side for brake or steer.

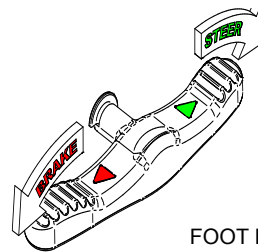

FOOT END PEDAL

Engage steer:

1. To engage steer at head end, put pedal in fully up position. To engage steer at foot end, put pedal in fully lower position on the green arrow side of the foot pedal in lower position.
2. Move the bed on a distance of approximately 2 feet towards desired direction for the steering caster activation. A "click" sound indicates that the caster is locked for steer motion.

Drainage bag support

Two drainage bag supports with grooves are located on each side of the bed frame, under the seat section. Refer to [product illustration](#) (page 6) for localization. Weight on the supports will be included to the displayed patient weight.

Accessory and equipment sockets

Sockets of 3/4" are located in each corner bumper of the bed. At head end of bed, are located two 5/8" sockets, two 1" sockets and two 1 1/2" sockets.

Patient restraint location

Six locations are available for patient restraint straps. Four are located under the mattress surface, two at head end of bed (A) and two at foot end of bed (B), and two are located on each side of the seat section (C). Refer to illustration on the right for localization.

WARNING

- Severe patient injuries could result of an improper usage of restraint straps. Healthcare professionals shall ensure proper restraint straps usage, location and adjustment.

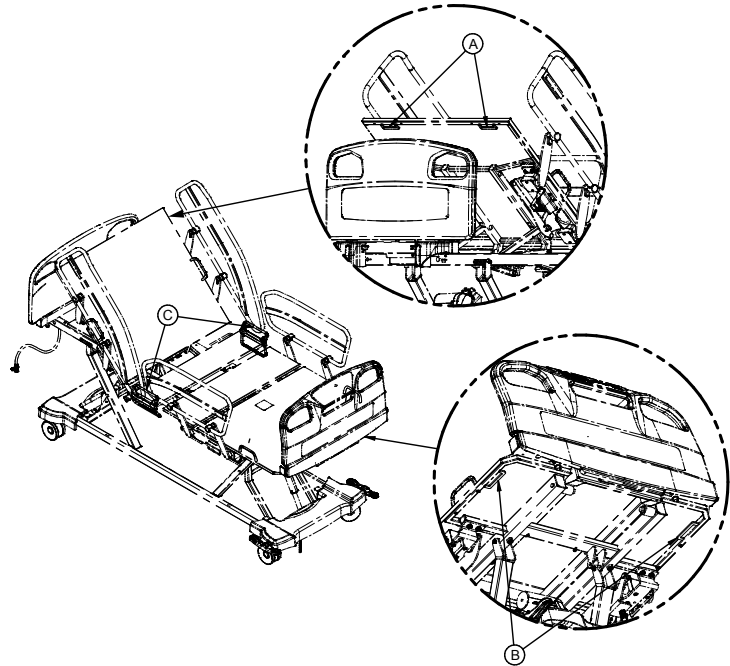

Bumpers

Bumpers are located at each corner of bed to preserve wall. Each bumper offers a 3/4" socket to support IV poles.

Bumpers with side view lights

Bumpers with integrated side view light system are located at both foot end corners of the bed. Foot end bumpers offer a 3/4" socket to support IV poles. The green lights intensity can be controlled through the display screen; refer to the [footboard control](#) section (page 35). The side view light system will give the status of the bed exit system:

- lights off: bed exit is not in use
- solid green: bed exit is armed
- flashing green: patient has been detected and bed will arm when patient is properly positioned in bed
- flashing amber: bed exit has been triggered
- solid amber: bed exit is in pause mode

IMPORTANT

An audio alarm can also be set; see bed exit control system settings in the [Footboard control](#) (page 35).

Power cord support brackets

Support brackets are available at the head end of bed (illustrated) to store the power cord during transportation or when not in use.

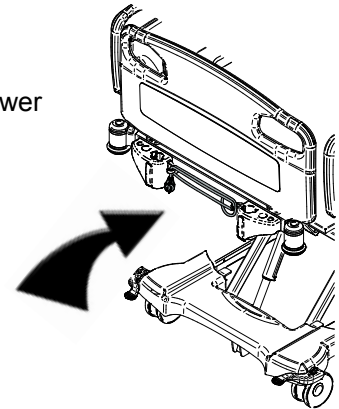

CPR release

CPR release handles are located on each side of the bed frame, under the backrest section. Usage shall be limited to emergency situations only. An over usage could lead to mechanical degradation.

Operation:

1. To activate, pull and hold the CPR release handle to flatten all sections of patient sleep surface.
2. Release handle once surface has reached flat position. If released before surface is completely flattened, all sections will stop retracting.



WARNING

- CPR release option usage shall be restricted to emergencies. To avoid injuries or product damages, ensure total clearance around product prior to usage.



ATTENTION

- Usage shall be limited to emergency situations only. An over usage could lead to mechanical degradation.
- If bed operates on battery, the thigh section will not reach flat position.

IMPORTANT

Thigh section will not reach flat position if master lockout of thigh section or, a movement function of any control is activated during motion.

Nurse call connector

The connector will be located at the head end of the bed, on the frame. The connector is only designed for nurse call function. Communication will be sent through system for a nurse call initiated by the patient and/or for a bed exit control alarm. Ensure the plug is properly inserted into connector.

Auxiliary power outlets and USB port

Bed is equipped with 120V auxiliary power outlets and USB port intended to be used as convenient power source for patient and caregiver use to energize low power devices. Power outlets are limited to 5A or 600W, with protective earth terminal. Both are located on the right side, one at the foot end of the bed, the second under the drainage bag support. The power outlets and USB port will not be functional if bed is unplugged.

DANGER

- DO NOT use the auxiliary power outlets for powering a life-sustaining device.

WARNING

- The auxiliary power outlet is limited to 120V 5A supply. Ensure connected devices are within this rating. High power device or uncertified devices may cause electrical hazards.

ATTENTION

- The organization responsible for usage and for maintenance of a medical electrical system shall ensure that the equipments connected on the auxiliary power outlet are conforming to the electrical specifications like, but not limited to, power drawn, leakage currents or electromagnetic compliance for electromedical systems (IEC60601-1; 2005).
- Ensure proper power supply and proper grounding reliability with the bed power cord connected to a hospital grade outlet. Failure to comply may cause electrical hazards, or result in loss of power to the connected device.
- Do not connect devices in the auxiliary power outlet while their switch is turned ON.
- Do not use extension power cord, or multiple socket outlet, on the auxiliary power outlet.
- The auxiliary power outlets will not operate if bed is unplugged.

Operation:

1. Ensure that the device required to connect to the auxiliary outlet is at OFF status. Ensure that cord and plug are in proper condition. Failure may result in inadvertent activation of the device connected and related hazards.
2. Ensure the device has a power rating below 5A at 120VAC for a NEMA 5-15 plug, or 5V 3.1A for USB plug.
3. Insert completely the NEMA 5-15 plug or the USB plug in the auxiliary outlet. Ensure no simultaneous contacts are made with the surroundings. Failure to comply might result in electrical shocks.
4. Ensure the bed power cord is connected to AC power through a hospital grade outlet.
5. Ensure the device to energize can be turned ON safely. Turn ON and use the device connected to the auxiliary outlet.

Communication port

Bed can be equipped of a USB communication port intended to be used for software updates and/or bed diagnosis.

IMPORTANT

The communication port will not be functional if bed is unplugged.

This communication port shall not be used as a power source for portable devices.

Control on frame

A control located on the frame, at the foot end of the bed, offers complementary functions to siderail controls in case the bed footboard is removed;

- lockouts of head or foot section motion
- lockouts of hi-lo
- Trendelenburg
- reverseTrendelenburg
- bed-exit system activation/deactivation
- battery charge level



Do not use a sharp or small pointed object on membranes to avoid permanent damages.

IMPORTANT

Refer to the [footboard control](#) section (page 35) for details on functions and related pictograms.

Nightlight

Two nightlights are located on each side of the bed frame, under the seat section, to illuminate the floor area where the patient will get in or out of the bed. Light intensity can be controlled through the display screen; refer to the [footboard control](#) section (page 35).

Bed extender

The bed extender allows the user to extend the length of the patient sleep surface from 80" to either 84" or 90". Usage of a mattress of appropriate length is required.

WARNING

- Siderails are designed to prevent patient to inadvertently fall from the bed.
- Extension of patient sleep surface will reduce the ratio of the bed perimeter covered by the siderails. Ensure proper monitoring to prevent patient to slip at foot end and avoid possible injuries caused by patient fall.

Operation:

1. Flatten patient sleep surface completely.
2. Reach extension handle located at foot end, under the deck (illustrated).
3. Pull and extend to 84" or 90". Ensure it is properly locked in position.
4. Properly install a mattress of appropriate length.
5. Ensure that extension is locked prior to put the bed in service.

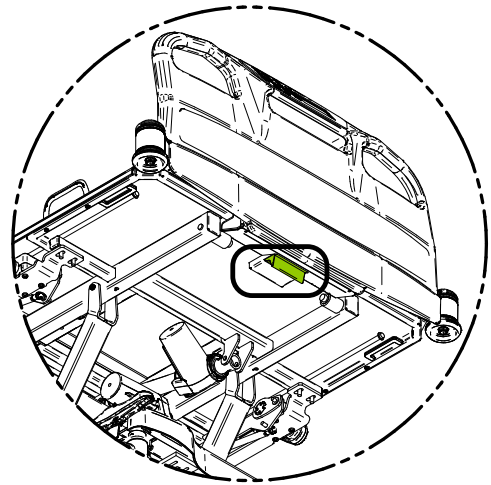

IMPORTANT

Remove patient from bed before set up of bed extender.

After extending or retracting bed with bed extender, ensure to perform a zero on the bed. Refer to [Zeroing procedures](#) section (page 22).

HEAD AND FOOT ENDS SIDERAILS

WARNING

- Siderails are designed to prevent patient of inadvertently fall from the bed.
- Siderails are not designed nor intended for patient restraint. If not avoided, situation could result in patient injury.
- If siderails are used by patient as a grip handle, they shall be used with caution. Abusive usage could result in bed tipping over and could result in moderate to severe injuries and damages to product and/or environment
- Do not use siderails to move the bed. If not avoided, situation could result in mechanical damages, which could lead to patient fall. Use headboard or footboard to move the bed.

Backrest section angle degree indicator

An integrated angle degree indicator is located on the external side of the head siderail and can be used as a reference for patient positioning. Reading from -15° to 75° .

Positioning siderail

Bed is equipped with 2 head siderails and 2 foot siderails. Each siderail operates with a release handle located at the bottom center.

Raise a foot or head end siderail:

1. Grasp the upper center of the rail and pull up until it latches into the locked position: a click will be heard.
2. Verify that the siderail release handle displays a green window for a locked status.
3. Ensure that siderails are properly locked; lightly push down the rail at head end to verify it is correctly latched, and perform a head to feet movement with the rail at foot end to verify it is correctly latched.

Lower a foot or head end siderail:

1. Grasp the upper center of the rail; with second hand, pull the handle up and rotate downward.
2. Siderail will be below the mattress surface. The handle will display a green window for an unlocked but safe status.

WARNING

- If the handle window display is red, the siderail has not reached a patient safe position. Ensure that siderail has completed its motion up or down for the display window to turn green.

Patient siderail controls

Patient siderail controls are located on the inside of each head siderail. Do not use sharp or small pointed objects on membranes to avoid permanent damages. Pictograms inform the user of positioning possibilities and features.

IMPORTANT

Refer to the [pictograms and definitions](#) section (page 13) to support identification.

To adjust sleep surface:

The UP/DOWN press buttons offer motion of backrest section from 0 degree to 60 degrees. The UP/DOWN press buttons offer motion of thigh and foot sections. Motion can be simultaneous.

To activate:

1. Press and hold button.
2. Release button when the required position is reached.

In addition, press buttons offer back lighted patient controls and possibility for the patient to send a call to the nurse station.

To use nightlight and nurse call:

- Press the light bulb button to turn ON back lighted controls and press again to turn OFF.
- Press nurse call button to send signal to nurse call communication system and station. Nurse call button pictogram is represented by a white bell on red background; refer to [Pictograms and definitions](#) section (page 13).

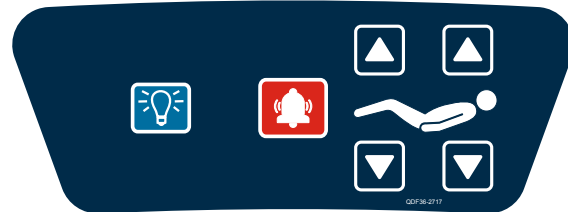

PATIENT CONTROLS ILLUSTRATED

Patient control

Patient control can be used to allow patient or healthcare personnel to activate certain bed functions. Do not use sharp or small pointed objects on membranes to avoid permanent damages. Pictograms inform the user of positioning possibilities and features. Patient control can be plugged in “MJB” junction box; refer to section [Removable patient control 2 functions](#) (page 55) for plugging instructions.

IMPORTANT

Refer to the [pictograms and definitions](#) section (page 13) to support identification.

The control lock from the footboard control will lock the functions of the patient control.

2 functions removable patient control (optional)

The UP/DOWN press buttons offer motion of backrest section from 0 degree to 60 degrees. The UP/DOWN press buttons offer motion of thigh and foot sections. Motion are simultaneous.

To activate:

1. Press and hold button.
2. Release button when the required position is reached.
3. Store and clip patient control on siderail upper tube.

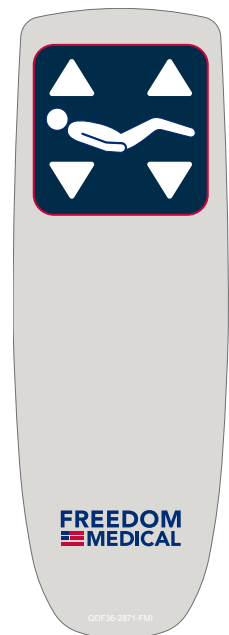

Caregiver siderail controls

Caregiver siderail controls are located on the outside of each head siderail. Do not use sharp or small pointed objects on membranes to avoid permanent damages. Pictogram informs the user of positioning possibilities and features.

IMPORTANT

Refer to the [pictograms and definitions](#) section (page 13) to support identification.

To adjust sleep surface:

The UP/DOWN press buttons offer motion of backrest section from 0° to 60°, motion of thigh and foot sections simultaneously and elevation system in a height range from 10" to 30".

To activate:

1. Press and hold button.
2. Release button when the required position is reached.

In addition, press buttons offer one touch positioning for a 30° of backrest section, chair position and flat surface. A LED indicator ON indicates that the bed is power supplied.

To use one-touch positioning buttons:

- Press and hold the button for a 30° angle of Backrest section.
- Press and hold the button for the chair-position positioning.
- Press and hold button to flatten patient sleep surface.

IMPORTANT

One button press positioning will not operate if bed is unplugged.

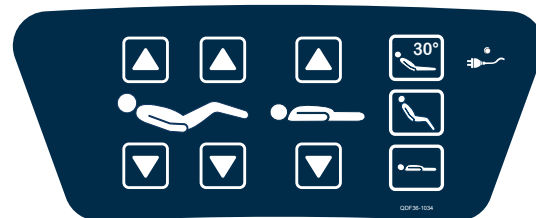

CAREGIVER CONTROLS ILLUSTRATED

HEADBOARD AND FOOTBOARD

Built-in transport handles

Headboard and footboard are both equipped of built-in pull-push handles to ease transportation.

Headboard

Ensure the headboard is installed on proper side as marked. Reverse position would make gaps wider and could result in increased risk of patient entrapment. Refer to labeling on headboard if required.

Integrated pump holder

An integrated pump holder is located in the center of the footboard. Ensure the device is secured and properly installed.

Footboard control

Footboard control is located on the board at the food end of the bed. Do not use sharp or small pointed objects on membranes to avoid permanent damages. Pictograms inform the user of positioning possibilities and features.

IMPORTANT

Refer to the [pictograms and definitions](#) section (page 13) to support identification.

Power up and battery charge level

A green LED indicator constantly ON by the power cord pictogram indicates the bed is power supplied.



If bed operates on battery, after 2 minutes of non-motion, the sleep mode will activate to save energy; all LED indicators will turn off, power cord LED indicator will be off. The battery charge level is given by the battery pictogram with integrated LED.

- No LED section ON, bed is plugged and power supplied: battery is fully charged.
- 3 LED sections flashing green, bed is plugged and power supplied: battery charging, all functions can operate.
- 3 LED sections solid green, bed is unplugged: battery fully charged - only bed motions will operate.
- 2 LED sections solid green, bed is unplugged: battery level decreased - only bed motions will operate, beep at activation.
- 1 LED section solid red, bed is unplugged: battery level is low - none of bed functions will operate, constant beep signal at activation.

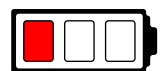
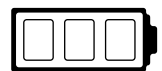

Footboard control with display screen

WARNING

- The bed exit detection system must be used with patients with minimum weight of 50 lb/22.6 kg. If not avoided, the bed exit detection system may not detect all movements and the functionality could be affected.

Bed motion lockout to the siderails controls can be set with one of the 3 closed padlock pictogram press buttons with integrated LED. A solid amber LED ON indicates that bed motion illustrated below is locked in the siderails, the bed motions can still be activated from the footboard control panel. To unlock motion, press the button displaying the amber LED ON.

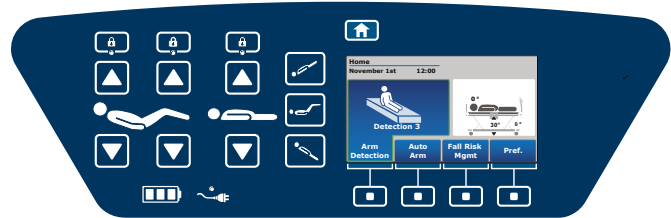

The UP/DOWN press buttons offer motion of backrest section from 0° to 60°, motion of thigh and foot sections simultaneously and elevation system in a height range from 10" to 31.5" depending on casters option. Press buttons offer one-touch positioning for:

- 16° Trendelenburg position
- Vascular foot position
- 16° reverse Trendelenburg position

To activate:

- Press and hold button.
- Release button when the required position is reached.

Navigation buttons are associated with the menu displayed above in the screen. Menus highlighted in blue are associated with actions whereas menus in grey are not and cannot be selected in this specific screen. Use buttons associated with arrows to navigate, button associated with "Select" for a selection or "Close" to exit menu. The information section is displayed in white, when applicable, on left side.

User can return to the Home screen menu at any time by pressing on the Home button.

Refer to the [pictograms and definitions](#) section (page 13) if required.

IMPORTANT

Screen will fall in sleep mode when not in use and display a screen saver if configured. Refer to the [Power up and modes of operation](#) section (page 23) for sleep mode details; refer to [Inform screen menu](#) section (page 42) for screen saver details.

Home screen

Screen informs the user of the height and the angulations of patient sleep surface. User can return to the Home screen menu at any time by pressing on the Home button.

IMPORTANT

The bed height is rounded up.

The angulations accuracy of backrest section is +/- 2°.

The angulations accuracy of Trendelenburg and reverse-Trendelenburg is +/- 2°.

A simplified interface displaying less options is offered for a simplified use. It is possible to change the interface through the Preference menu, in the Maintenance menu. On the Standard interface, the Auto Arm button and the Inform button are not displayed. If PIN protected, contact maintenance for access.

A password can be requested when screen is activated after sleep mode.

Select:

- Arm (Disarm)** to arm or disarm the bed exit control system. The pictogram on the button informs of the pre-selected detection level. Press the ARM button to arm the Bed exit control system. Screen will return to the Home screen and menu header will change to disarm. Menu display, if patient is in bed, will turn green to indicate the bed exit control is activated. If the patient is not in bed, the menu display will turn flashing orange, in alarm, and bumpers with side view lights will turn ON, solid green, or will be flashing orange. If the bed exit control is triggered, the pre-set tone and volume will activate. Press the button associated with Disarm to deactivate the alarm or bed exit control. Refer to the [Patient risk management screen menu](#) section (page 40) for Auto setting, selection of levels of detection and setting of volume and tone.
- Patient Risk Mgmt** to access selection for levels of detection for bed exit control, volume and tone selection for alarm settings, Inform menus, or view the patient risk management log.
- Scale** to access the integrated scale system menus.
- Pref.** to access preferences menus for language, screen brightness, nightlights and sideview lights, date and time, bed ID settings and, access the maintenance menu. If applicable, a short cut to Errors log will be prompted. If pre-setted, a short cut to Lock of motion and to Patient risk management will be prompted.

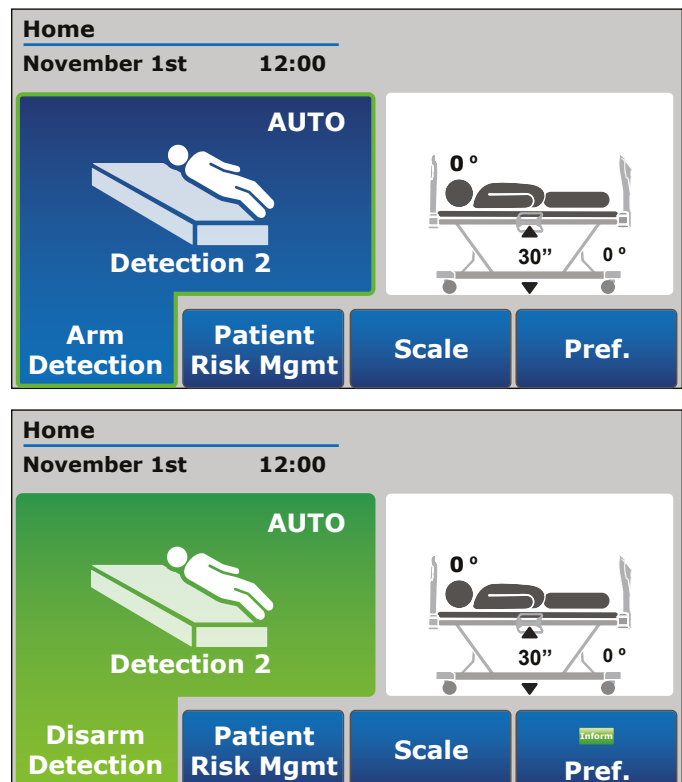

- **Auto Arm in Arm Detection** to arm automatically the bed exit detection when patient ingresses in bed. If user selected the standard interface, the Auto Arm button is not displayed on the home screen.

Configuration steps:

1. From the Home screen, press the Arm Detection button.
2. Select appropriate answer to the prompt question message box in order to arm or disarm the Auto Arm detection option.
3. When selecting the Auto Arm option, AUTO will appear on the upper right corner of the Arm Detection button on the screen.
4. When Auto Arm is activated and patient is detected in bed, a message box will appear to indicate that the patient has 60 seconds to settle in bed before the bed exit is armed automatically. If patient is not settled after 60 seconds or if patient gets out of bed before 60 sec. is over, bed exit detection system will fall in alarm.

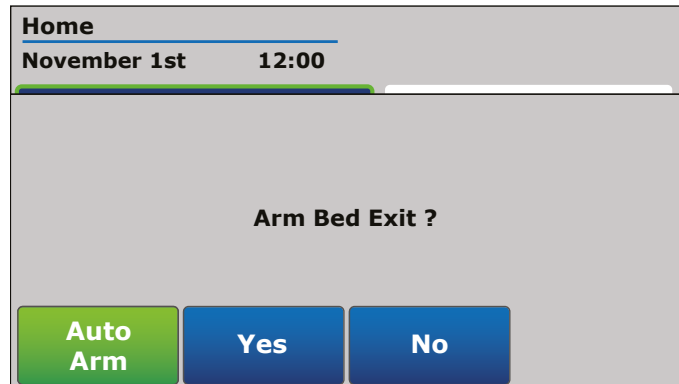

Care Pause

When the bed exit detection is armed, press the Disarm Detection button to apply a Care Pause and give the caregiver 5 minutes to provide any care to the patient without disactivating the bed exit system and without generating a bed exit detection alarm. The detection button on the screen will turn orange and the time left for the pause will appear. If applicable, the sideview lights bumpers will turn solid orange for the duration of the pause.

Select:

- **Care Pause** to apply a 5 minutes pause to the armed bed exit detection.
- **Cancel** to return to the Home screen.

Anytime during the pause, the time can be resumed to 5 minutes if needed. When 30 seconds remain, an audible sound will be heard and the time left will be displayed and flashing in the screen. When only 10 seconds remain, another audible sound will be heard.

Select:

- **Deactivate Pause** to deactivate the pause completely.
- **Resume to 5 min.** to reset the time to a total of 5 minutes.
- **Close** to keep the remaining time the same and to return to the Home Screen.

When Auto Arm is activated and the pause finishes, the system will start the auto detection. When detected, the patient has 60 seconds to settle in the bed before the bed exit is armed automatically.

When auto-arm is activated and bed is in alarm while patient is still in bed, press the Disarm Detection button to stop the alarm. The system will automatically apply a one-minute pause to the auto-arm to allow the caregiver to attend to the patient. Press on the Detection button to apply a 5-minute care pause if needed. If time runs out after one minute, the bed automatically returns to the auto-arm mode. Refer to the [Home screen](#) section (page 37).

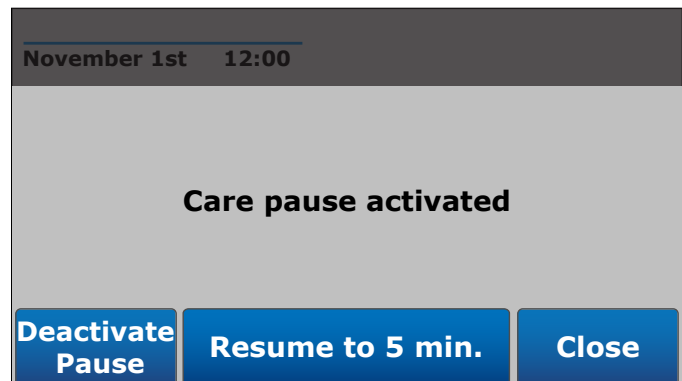
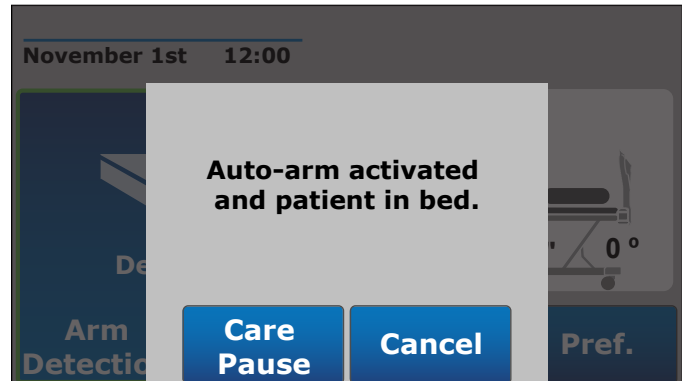

Patient risk management screen menu

Navigate and select:

- **Set Detection** to access the bed exit detection settings. The displayed pictogram informs of the pre-selected detection level.
- **Alarm Settings** to access the volume range and the tone selection.
- **Log** to access the bed exit log.
- **Inform** to set up a screen saver configured to inform caregivers with color coding and/or different pictograms from the Pictograms library and/or siderail configuration requirements based on patient condition.
- **Close** to exit menu.

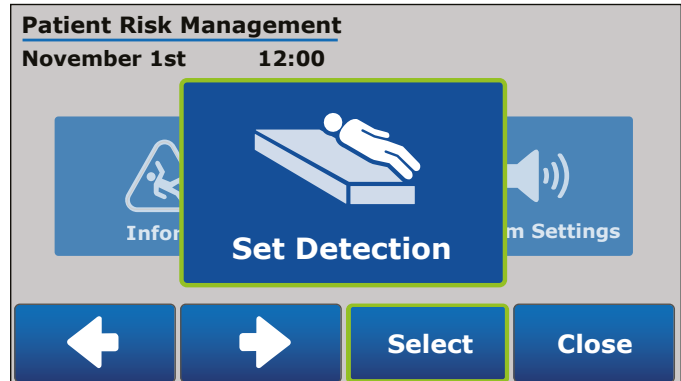

IMPORTANT

A simplified interface displaying less options is offered for a simplified use. It is possible to change the interface through the Preference menu, and then through Maintenance menu. On the Standard interface, the Auto Arm button and the Inform button are not displayed. If PIN protected, contact maintenance for access.

In the Home screen, the Preference box displays the symbol for Lockout and the Inform pictogram if selections made in Inform. The Preference menu offers short cuts to get to Inform menu or to Lockouts screen menus.

Set Detection screen menu

The displayed pictogram informs of the pre-selected detection level. The ARM button will change to DISARM if the bed exit control system is activated.

Navigate and select:

- **Detection 1** to change level of detection to a patient out-of-bed. Press ARM to set. Press DISARM to deactivate the bed exit control system. Press CLOSE to exit menu.
- **Detection 2** to change level of detection to a patient attempting to get out of bed. Press ARM to set. Press DISARM to deactivate the bed exit control system. Press CLOSE to exit menu.
- **Detection 3** to change level of detection to a patient movement in bed. Press ARM to set. Press DISARM to deactivate the bed exit control system. Press CLOSE to exit menu.
- **Auto Arm** to activate or deactivate the bed exit detection when patient ingresses in bed. Auto arm button turns green when activated and AUTO displays on Arm/Disarm button in Home screen.
- **Arm/Disarm/Select** to arm or disarm the bed exit control system for the highlighted detection level or, change the detection level.
- **Care Pause** to activate a 5-minute pause on a bed exit detection when the Auto Arm is activated.
- **Close** to exit menu.

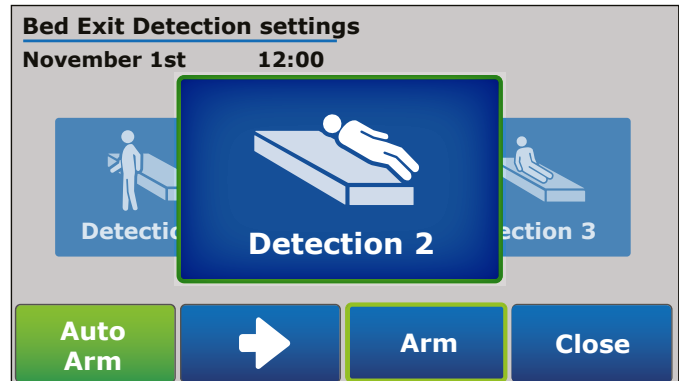

Alarm Settings screen menu

The Alarm Settings screen menu offers a selection of volume levels and selection of different tones. Navigation with arrows will demonstrate the volume level or tone if volume is not muted.

Navigate and select:

- **Volume level** between ranges of 4 volume levels including mute.
- **Tone selection** between a ranges of 10 different tones.

Select:

- **Select** to set alarm settings as displayed.
- **Cancel** to cancel command and exit screen menu.

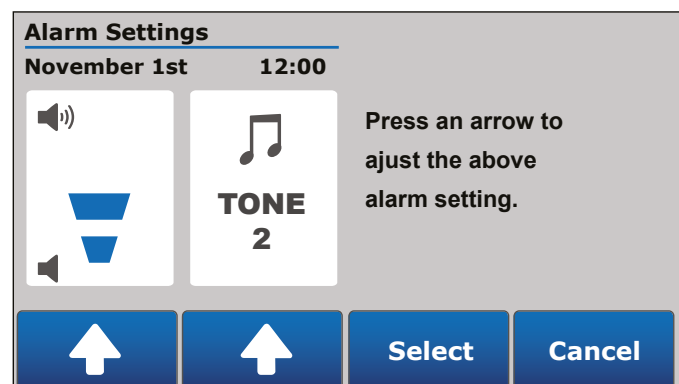

Inform screen menu

The Inform screen menu offers the possibility to set a screen saver with display of the different pictograms selected from the Pictograms library to inform caregivers of patient condition and predisposition to fall, and/or display of required siderails configuration. The screen also offers possibility to set a color-coding with 1, 2 or 3 different colors.

If selected, the Inform pictogram will display in the upper right corner of the display screen and also displays on the Preference box.

IMPORTANT

In the Home screen, the Preference box displays the symbols related to the selection. Once selected, the Preference menu offers short cuts to get to Inform menu, to Active Errors or to Lockouts screen menus.

If selected, the different pictograms from the Pictograms library, the siderails configuration and the color coding will display on the screen saver after two minutes of inactivity.

Select:

- **Start** to display the screen saver with selected settings.
- **Activate/Disable** to activate or disable the display on screen saver, or to disable the feature associated with the above the button.
- **Close** to save settings and exit menu. Screen saver will activate after 2 minutes of inactivity.

Navigate and select:

- **Pictograms library** to add a visual indicator related to patient’s condition and to set screen saver with display of pictogram: can not drink liquids, patient risk, confusion, do not change bed configuration, two person required to move patient, allergies, blood sugar level, blood pressure, pressure ulcers and no visitors allowed. Background of button will turn green once one or more are activated. The Inform pictogram also displays in the upper right corner of the display screen to inform caregivers that indicators related to patient’s condition have been activated. A description of each of the pictograms from the library can be displayed on the screen saver, if selected.

Answer to the prompt question message box to confirm or cancel.

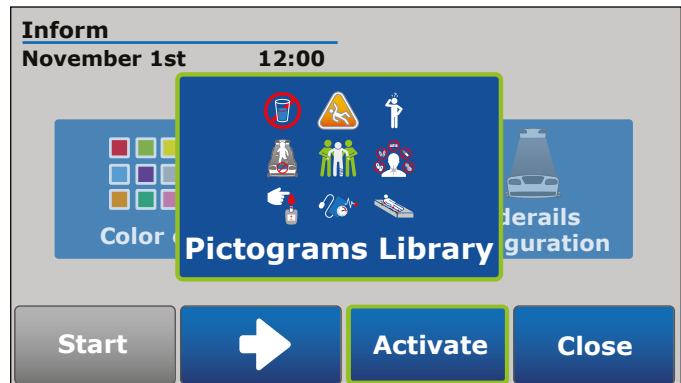

- **Siderails configuration** to set screen saver with display of required siderails configuration on the pictogram displayed on screen saver. Background of button turns green once configured and activated.

Configuration steps:

1. From the Inform menu, press the siderails configuration button.
2. Select appropriate answer to the prompt question message box in order to keep, or not, the configuration that was previously set up. YES will take you to Inform menu and NO will bring back to the configuration options.
3. When setting up the siderails configuration, the options chosen will appear on the bed image on the screen.
4. Once all indications are given, prompt question message box opens to confirm or cancel. Press Prev. to return to the siderails configuration screen.

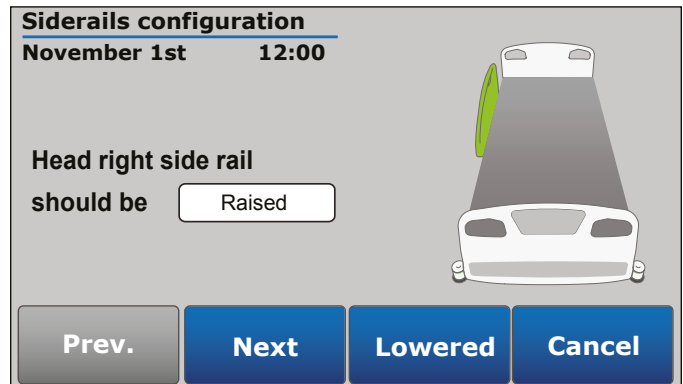

- **Color Code** to get to the Color selection screen, select 1, 2 or 3 colors and display selected colors on the screen saver.

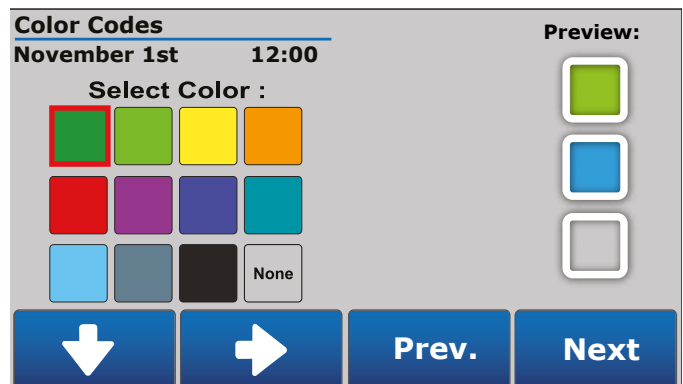

Patient risk management log screen

The Patient risk management log offers a log listing up to 100 entries related to activation and deactivation of features. Entries related to bed exit control are highlighted in green to indicate activation and highlighted in orange to indicate an alarm. Log displays the description, date and time of the activity.

Select:

- **UP/DOWN arrows** to scroll up or down the log.
- **Erase** to erase log entries. This activity can be protected by a password through the Maintenance menu.
- **Close** to exit menu.

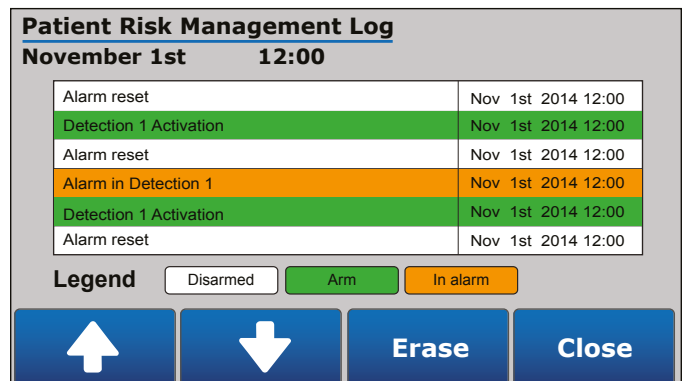

Preference screen

If applicable a short cut to Errors log will be prompted. If pre-set, a short cut to Lock of motion and to Inform will be prompted. Other preferences settings are accessible under Pref.

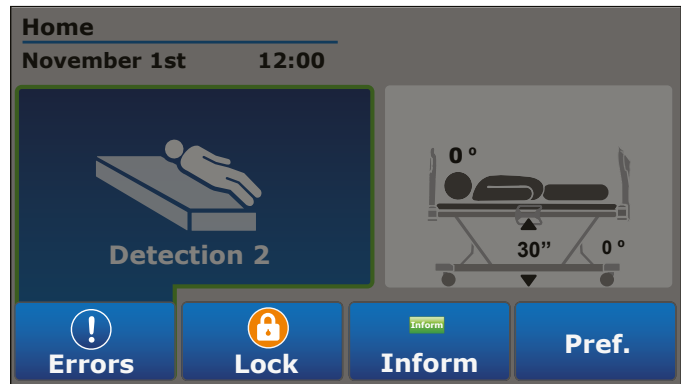

Use button associated with Close to exit menu. Use buttons associated with arrows to navigate the menu selection and use button associated with Select to select a menu.

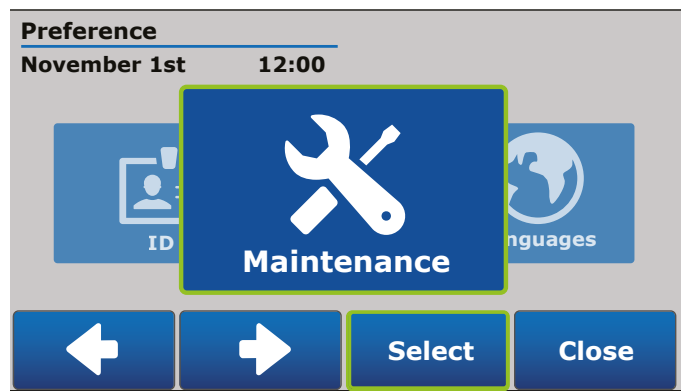

- **Maintenance** to access the errors log, active errors, calibration, load cell values, units selection, factory settings, software version, password settings and interface settings. Default protection by password. Contact Maintenance for access or refer to Maintenance Manual for instructions.
- **Languages** to select the language of internal communication.
- **Lights configuration** to set screen brightness, nightlight brightness (optional) and/or sideview lights brightness.
- **Date/Time** to set date and time.
- **ID** to give an identification label and/or color to the bed.
- **Lock** to activate lockouts of bed motion on the bed.
- **Min. height adjustment** to set or adjust the lowest height the bed can reach.

Languages screen

Select:

- **Cancel** to cancel command and return to preference menu.
- **Arrow upward** to set select language.
- **OK** to confirm selection and return to Preference menu.

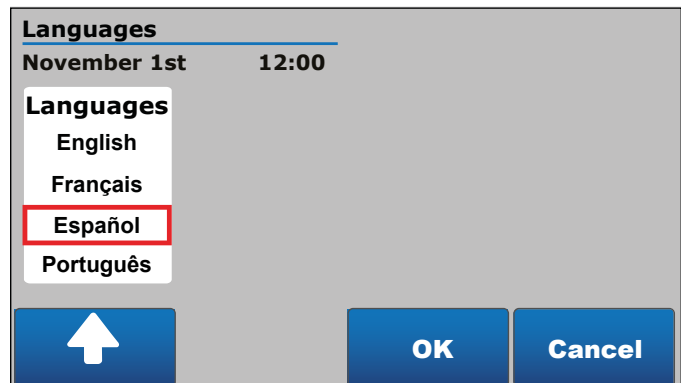

Lights configuration screen

Select:

- **UP arrow** for Screen brightness and select one of four levels of intensity.
- **UP arrow** for Nightlight brightness and select one of three levels of intensity or set to OFF.
- **UP arrow** for Sideview lights brightness and select one of three levels of intensity or set to OFF.
- **Close** to exit lights configuration menu and return to preference menu.

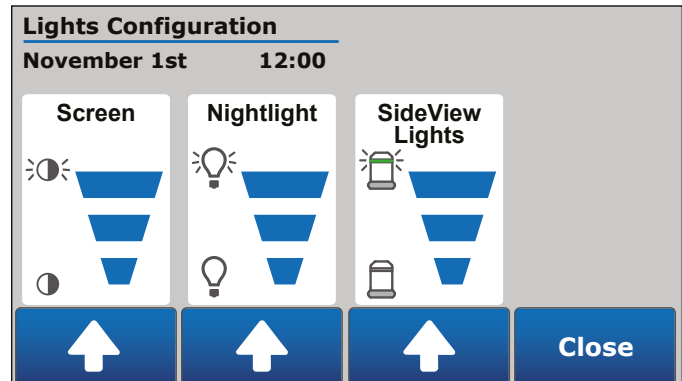

IMPORTANT

The Nightlight brightness will not display in this screen if option not activated in the Maintenance screen menu.

Date/time screen

By default, the Date is flashing and is pre-selected for editing.

Select:

- **UP/DOWN arrows** to edit, increase or decrease the date, month, year or time.
- **Arrow to the right** to navigate to the right.
- **Close** to exit menu. Confirm to save changes if applicable.

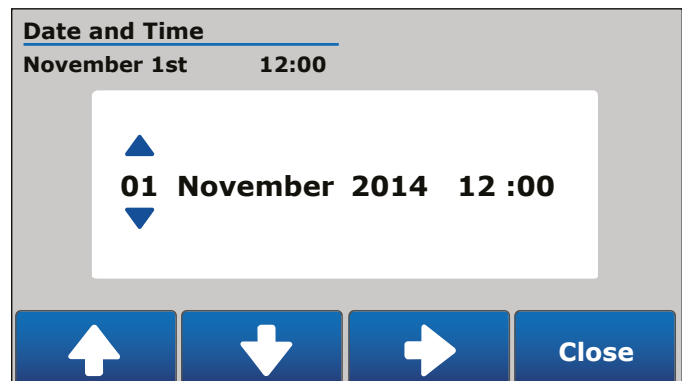

Identification screen

Use the ID feature in the Identification screen to label the equipment with a color code and text. The label will display over the date and time in the Home screen. A maximum of 20 digits can be entered as a text label.

Select:

- **Arrow upward/ to the right** to navigate the keyboard or color selection.
- **Validate** to set text entry and color selection as a bed identification and exit menu.
- **Close** to save, or not, change and return to the Preference screen.



Navigate and select:

- **Color** to get to the Identification color screen. Select one color to give a colored label to the display screen, or select None. Select Close to save, or not; return to the Identification screen.
- **Keyboard arrow to the left** to go backspace in the text window.
- **Keyboard arrow upward** to switch from lowercase letters to uppercase letters.
- **123#** to get from the alphabetical keyboard to the numbers and special characters keyboard.
- **ABC** to get from the numbers and special characters to the alphabetical keyboard.

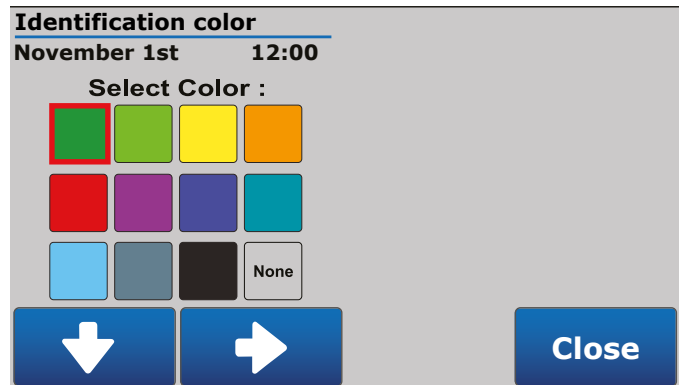

Lock screen

The Lock screen offers activation of a total lockout for motion of backrest section, knee gatch and/or Hi-Lo. Total lockout activation also displays an orange padlock on the Preference box in the display screen to inform caregivers.

Select:

- **Back lock** for activation of lockout for motion of backrest section.
- **Foot lock** for activation of lockout for motion of knee gatch section.
- **Hi-Lo lock** for activation of lockout for motion of Hi-Lo section.
- **Close** to confirm save of settings and return to Preference screen.

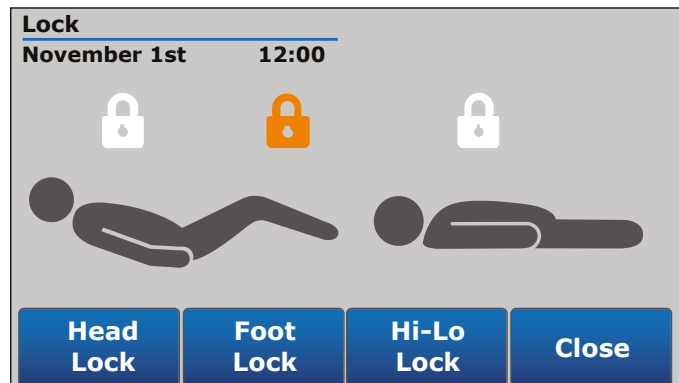

IMPORTANT

Total lockout, when activated through the display screen, will not operate if bed is on battery mode or if footboard is removed. Ensure that the proper settings according to the patient's condition are in place.

Min. Height Adjustment

The minimum height adjustment screen offers to set minimum bed height depending on the needs of the caregiver or of the patient. When the bed's lowest height is reached, a "min. height" indication will appear on the Home Screen.

Select:

- **UP/DOWN arrows** to navigate and select the minimum height of the bed.
- **OK** to confirm selection and return to Preference screen menu. This activity can be protected by a password through the Maintenance menu.
- **Cancel** to cancel command and return to Preference screen menu.



Scale screen

For proper use of scale related features, ensure bed is not interfering with any item of the environment or in contact with wall. Do not touch bed.

Select:

- **Scale** to display and log patient weight. Select Weigh to display weight.
- **Zero** to “zero” the scale settings. Menu mentions that patient shall not be in bed and to install equipment if appropriate prior to start. Do not touch bed while zeroing, or cancel command. Screen returns to the Scale menu selection once completed.
- **Weight log** to access the weight log and read patient logged weight.
- **Change equipment** to add or remove equipment on bed. Message box mentions not to touch bed during weight, then select OK when equipment is added or removed. Select CANCEL to cancel command.

If weight on bed is more than 225 kg, an "overload" mention will be displayed instead of the weight when "Weigh" button is selected.

When annual calibration is required, the weight is displayed but a "calibration required" error is logged and displayed in the scale menu.

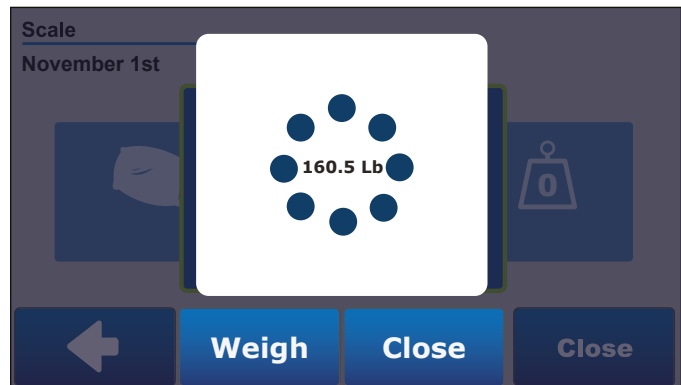
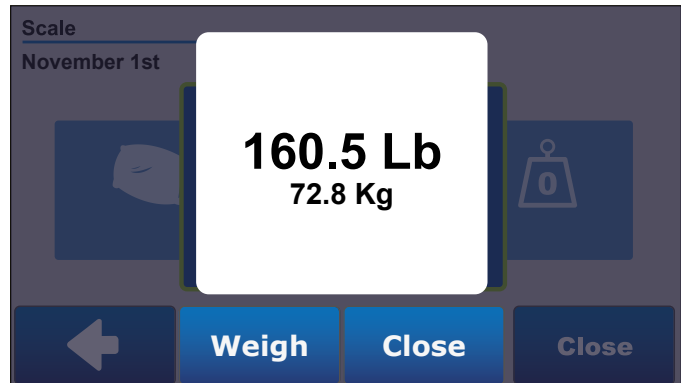

Weight Log screen

The Weight Log screen informs of patient logged weight and records up to 20 entries. Use arrows to navigate and read from oldest to most recent entry. Erase Weight Log entries by selecting ERASE. This activity can be protected by a password through the Maintenance menu. Confirm intention to erase, or cancel command by selecting NO. Select CLOSE to return to Scale screen.

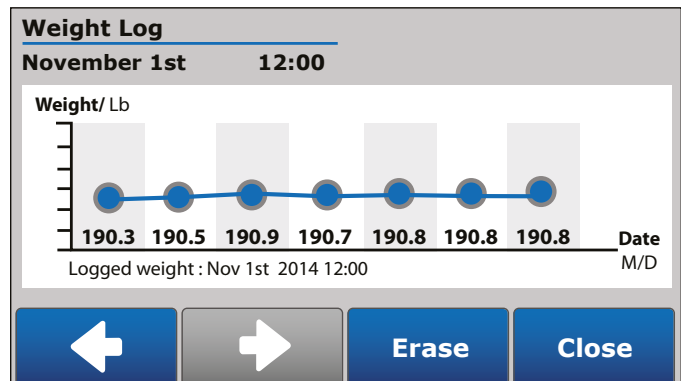

ACCESSORIES

WARNING

- Always ensure precautions are taken when using compatible accessories in foot section accessory sockets. Foot section accessory sockets are attached to the moving part of the frame. If foot section requires to be actuated, accessory will follow the foot section angle and will be tilted or moved away from patient.

1" fixed IV pole for 1" socket - FA64508-FMI

The fixed IV pole FA64508-FMI is equipped of 2 hanging hooks. Each hanging hook has a capacity of 11 lb/5 kg for a total maximum safe working load of 22 lb/10 kg.

ATTENTION

- IV pole total safe working load is 22 lb/10 kg.
- IV pole is not intended to be used as a push bar; if not avoided permanent damages to the product could occur.
- Fully extended fixed IV pole length is 46", consider maximum bed height of 31" if transporting bed, or if lighting or ceiling is low. IV pole will move with bed when elevation system activated. Ensure proper clearance.

Installation:

1. Remove screw from bottom of IV pole.
2. Insert the fixed IV pole in one of two 1" sockets.
3. Using a # 3 Philips screwdriver, fixe IV pole with screw.
4. Ensure IV pole is properly fixed.

Operation:

1. Ensure IV pole is properly fixed.
2. To adjust the height of the IV pole, hold the upper section and turn the clamping ring counterclockwise to loosen the upper section.
3. Adjust the upper section to required height and turn the clamping ring clockwise until upper section is locked.
4. Ensure upper section is properly locked in place.

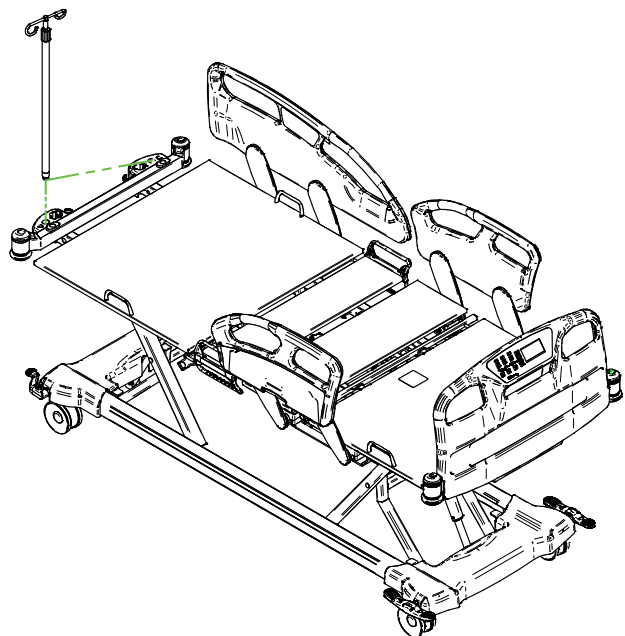

Left 1" folding IV pole for 1" socket - FA64521-FMI

The folding IV pole FA64521-FMI is equipped of 2 hanging hooks. Each hanging hook has a capacity of 11 lb/5 kg for a total maximum safe working load of 22 lb/10 kg. The left folding IV pole FA64521-FMI can be combined to the right folding IV pole FA64523-FMI for additional hooks.

ATTENTION

- IV pole total safe working load is 22 lb/10 kg.
- IV pole is not intended to be used as a push bar; if not avoided permanent damages to the product could occur.
- Fully extended folding IV pole length is 51", consider maximum bed height of 31" if transporting bed or if ceiling is low. IV pole will move with bed when elevation system activated. Ensure proper clearance.
- When used simultaneously, the FA64521-FMI and FA64523-FMI exceed of 1/4" at head end of the bed once folded. Use of roller bumpers is recommended in order to prevent potential damages to the walls.

Installation:

1. Remove screw from bottom of IV pole and from the IV pole storage support.
2. Insert the folding IV pole in the 1" left socket at head of the bed. Then insert the folding IV pole storage support in the opposite side 5/8" socket - as illustrated.
3. Using a # 3 Philips screwdriver, fixe IV pole and IV pole storage support with screws.
4. Ensure IV pole is properly fixed and folds properly.

Operation:

1. Ensure IV pole is properly fixed.
2. To adjust the height of the IV pole, hold the upper section and turn the clamping ring counterclockwise to loosen the upper section.
3. Adjust the upper section to required height and turn the clamping ring clockwise until upper section is locked.
4. Ensure upper section is properly locked in place.
5. Store when not in use.
6. If applicable, when in use of two folding 1" IV poles simultaneously, fold one of the poles (A) and install in support clip situated at base of opposite pole. Fold the second pole (B) and install in storage support on opposite side.

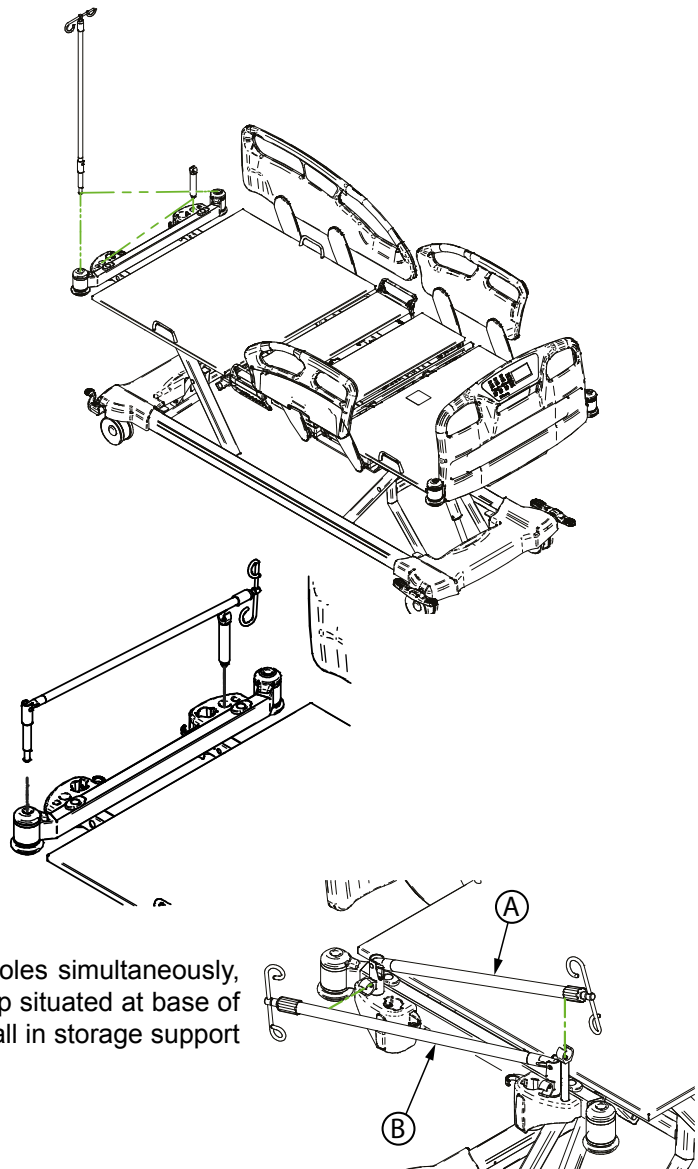

Right 1" folding IV pole for 1" socket - FA64523-FMI

The folding IV pole FA64523-FMI is equipped of 2 hanging hooks. Each hanging hook has a capacity of 11 lb/5 kg for a total maximum safe working load of 22 lb/10 kg. The right folding IV pole FA64523-FMI can be combined to the left folding IV pole FA64521-FMI for additional hooks.

ATTENTION

- IV pole total safe working load is 22 lb/10 kg.
- IV pole is not intended to be used as a push bar; if not avoided permanent damages to the product could occur.
- Fully extended folding IV pole length is 51", consider maximum bed height of 31" if transporting bed or if ceiling is low. IV pole will move with bed when elevation system activated. Ensure proper clearance.
- When used simultaneously, the FA64521-FMI and FA64523-FMI exceed of 1/4" at head end of the bed once folded. Use of roller bumpers is recommended in order to prevent potential damages to the walls.

Installation:

1. Remove screw from bottom of IV pole and from the IV pole storage support.
2. Insert the folding IV pole in 1" right socket at head of the bed. Then insert the folding IV pole storage support in the opposite side 5/8" socket - as illustrated.
3. Using a # 3 Philips screwdriver, fixe IV pole and IV pole storage support with screws.
4. Ensure IV pole is properly fixed and folds properly.

Operation:

1. Ensure IV pole is properly fixed.
2. To adjust the height of the IV pole, hold the upper section and turn the clamping ring counterclockwise to loosen the upper section.
3. Adjust the upper section to required height and turn the clamping ring clockwise until upper section is locked.
4. Ensure upper section is properly locked in place.
5. Store when not in use.
6. If applicable, when in use of two folding 1" IV poles simultaneously, fold one of the poles (A) and install in support clip situated at base of opposite pole. Fold the second pole (B) and install in storage support on opposite side.

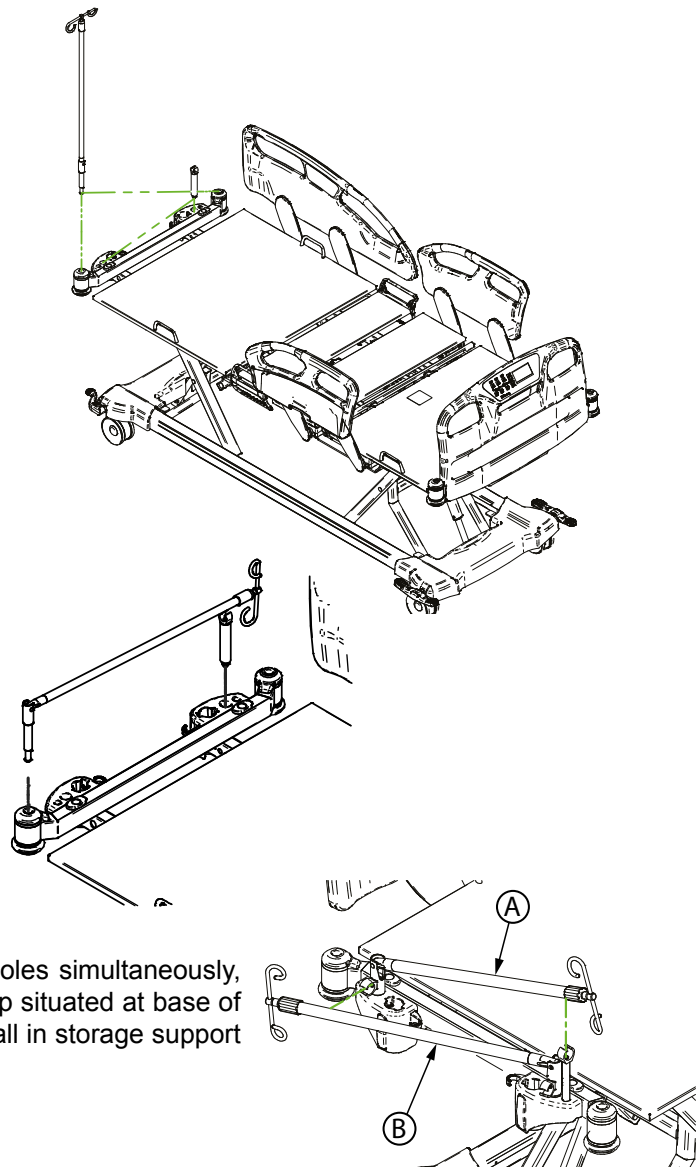

Removable pump holder - FA64513-FMI

The removable pump holder FA64513-FMI is intended to be installed on the footboard to support pumps. It has a maximum safe load capacity of 70 lb /31 kg

⚠ ATTENTION

- Remove accessory when not in use.

Installation and removal

1. Insert or remove the removable pump holder in/from the left and right holes located on the footboard.
2. Store if not in use.

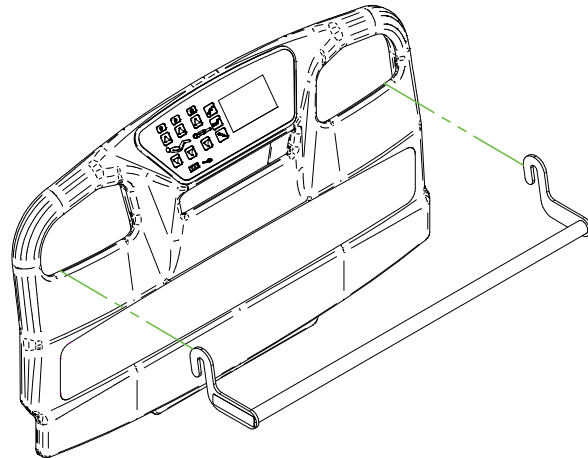

Oxygen bottle holder - FA64505-FMI

The vertical oxygen bottle holder is designed to support an oxygen bottle. It can be installed at the bed head end; it has a maximum safe load capacity of 35 lb / 16 kg.

Installation and operation

1. If applicable, remove the retaining pin from bottom of support bar.
2. Insert the support bar into one of head end corner bumper.
3. Insert the retaining pin into the bottom of the support bar.
4. Ensure oxygen bottle holder is properly installed and secured.

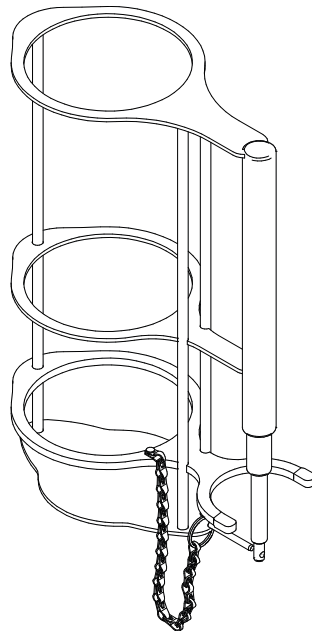
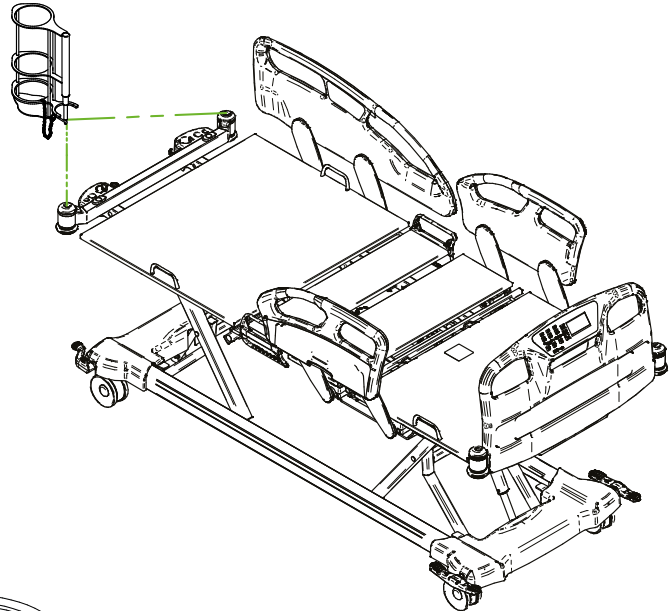

Patient helper - FA64504-FMI

The patient helper is intended to provide support to the patient for repositioning when in bed. It is not designed to support patient when getting in or out the bed. The maximum load capacity of the patient helper is 170 lb / 77 kg.

WARNING

- The maximum load capacity of the patient helper is 170 lb / 77 kg.
- The patient helper is not designed to support patient when getting in or out of bed. Abusive usage could result in bed tipping over and could result in moderate to severe injuries and damages to product and/or environment.

Installation:

1. If applicable, remove the retaining pin from bottom of the lower section.
2. Insert the lower section, roller bumper outside, into one of both 1 1/2" sockets located at head end.
3. Ensure it correctly and completely slides into socket and insert the retaining pin into the bottom of the lower section.
4. Pull the plunger located on the lower section and insert the upper section.
5. Release plunger.

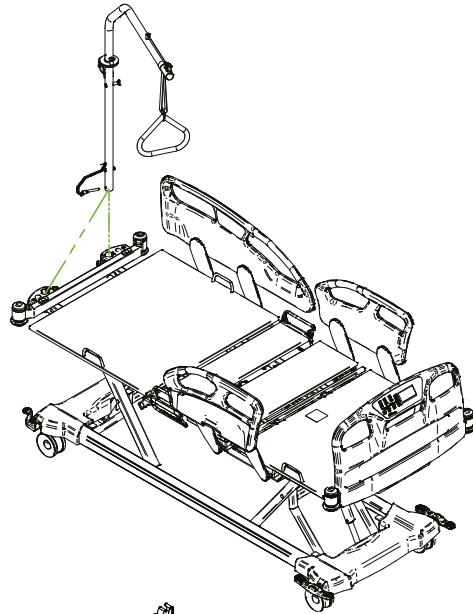

Operation:

1. Ensure patient helper is properly fixed.
2. To adjust the position of the patient helper, pull the plunger located on the upper section.
3. Pivot to adjust in range of 35° on left side and 35° on right side. Release plunger.
4. To adjust the height of the patient helper handle, shorten or lengthen the strap.
5. Ensure the handle is properly attached to upper section.
6. Store when not in use.

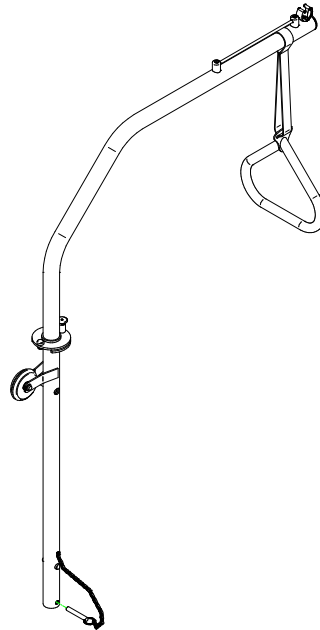

Removable patient control 2 functions - FA64511-FMI

The two functions patient control is intended to allow patient or healthcare professionals to adjust the backrest section and foot section of the bed. Pictograms inform the user of positioning possibilities and features. Do not use sharp or small pointed objects on membranes to avoid permanent damages.

ATTENTION

- Patient monitoring and patient authorized bed functionalities are the responsibility of the facility.

IMPORTANT

Refer to the [pictograms and definitions](#) section (page 13) to support identification.

The control lock from the footboard control will lock the functions of the patient control.

To unplug patient control from "MJB" junction box:

1. To remove the "MJB" connectors lock, use the flat blade screwdriver and apply a light upward pressure. Save for reuse.
2. Unplug patient control cable from "MJB" connector (D). Remove cable from the central mattress retainer.
3. Remove the clip (B) attached to the lower central mattress retainer. Use the flat blade screwdriver to remove the 3/4" cap (C) fixed to the bed frame, in the left longeron.

To plug patient control in "MJB" junction box:

4. To plug back the patient control, use the flat blade screwdriver to remove the "MJB" connectors lock if it is still in place.
5. Run the cable through the lower central mattress retainer and plug the cable in the "MJB" (D). Once cable is plugged in, put back the "MJB" connectors lock.
6. Fix the cable to the bed frame by inserting the 3/4" cap (C) attached to the patient control cable in the 3/4" hole situated in the left longeron.
7. Use the clip (B) attached to the cable to fix the cable on the lower central mattress retainer. Then, hook the patient control on the siderail or fix it to the bed sheets with the attached clip (A) to store.

To activate patient control:

1. Press and hold button.
2. Release button when the required position is reached.
3. Store and clip patient control on siderail or on bed sheets.

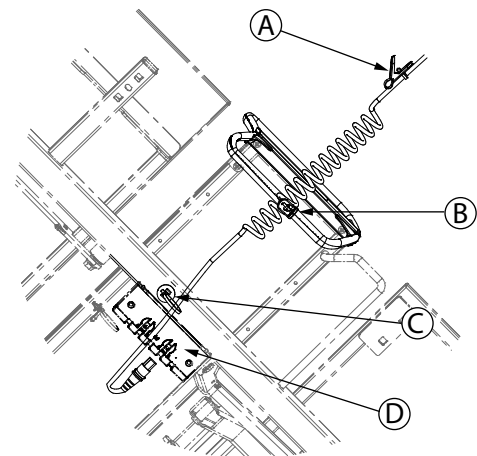
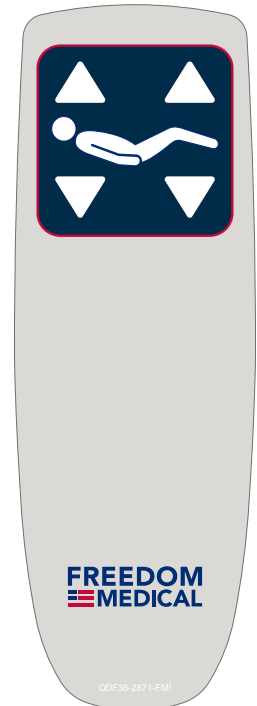

PREVENTIVE MAINTENANCE

A preventive maintenance is required annually for this equipment. This maintenance program is based on a normal use. Preventive maintenance frequency shall be increased if required. A minimum of one (1) annual verification of all items of the [Preventive maintenance annual checklist](#) (page 58) is recommended.



WARNING

- Only trained and authorized personal shall perform preventive maintenance and servicing on this equipment. If not avoided, situation could result in personal injury or permanent equipment damage.
- Only trained and qualified personal shall perform preventive maintenance and servicing on this equipment. If not avoided, situation could result in electrical or electronic misconnection and lead to shock or fire hazards.

IMPORTANT

Batteries have an intended lifetime of 5 years and should be replaced after 5 years or sooner, depending on battery backup usage.

If device is left unplugged for a long period, batteries will slowly drain. Do not fully drain batteries.

Batteries should be charged every 3 months. Plug the bed to a supply main with protective ground or to a hospital grade outlet that is protectively grounded for a minimum of 6 hours.

Ensure that battery is properly charged prior to perform the preventive maintenance verification. If applicable, secure any bed section that would have to be lifted during servicing procedures.

Preventive maintenance annual checklist

Use copy of this sheet for your records. Note if adjustment or repair were required. Keep on file.

Serial Number and Location :

Date of preventive maintenance:

Preventive maintenance performed by:

- Overall condition
- Fasteners
- Labels
- Casters
- Ground chain
- Brake, neutral and steer pedal
- Power cord
- Nightlight
- Actuators
- Battery
- Bumpers
- Mattress retainers
- Siderails mechanism
- Siderails control, membranes and LED lights
- Headboard and footboard
- Bed extender
- CPR
- Footboard control functions and LED
- Display screen
- Mattress
- Compatible accessories
- Zero
- Nurse call
- Scale calibration
- Current leakage and grounding
- Patient control (if applicable)

Notes, adjustments, repairs:

CLEANING

A potential of electric shock hazard exists with a power supplied bed. Ensure to unplug power cord of power outlet before cleaning. Do not put water or solution directly in or on connectors. If applicable, secure any bed section that would have to be lifted during cleaning procedures.

This bed and compatible accessories are not designed to be steam cleaned, hosed off or ultrasonically cleaned. Do not immerse any part of this bed or any accessory in any liquid. Permanent damages could occur.

All compatible accessories, except mattress, can be cleaned and disinfected the same way as the bed.

All equipments connected to the auxiliary outlets shall be cleaned and disinfected as per the manufacturer instructions.

Cleaning

Hand wash all surfaces with a soft clothe moistened with warm soapy water. Avoid build up and over saturation of water or any cleaning solution. Ensure that cleaning solution does not stay on surface longer than manufacturer's cleaning solution instructions. Always wipe clean and dry surfaces.

Disinfection

Bed and accessories should be disinfected between patient uses. This bed and compatible accessories are designed to be disinfected with standard commercial solutions. As guidance, here are active concentrations of tested ingredients:

- ammonium quaternary solutions 1000ppm
- sodium hypochlorite solutions 6000ppm
- glycol ethers solutions 10%
- ethyl alcohol 5%
- hydrogen peroxide 1%

Mattress cleaning and care

Mattress should be cleaned between patient uses. Refer to manufacturer's instructions for cleaning. Inspect mattress after use and discontinue if any cracks or rips are found as fluid may have contaminated the mattress.

WARRANTY

The **Freedom Medical** beds are designed for a 10 years service life under normal use, conditions, and with periodic maintenance as recommended in Maintenance Manual.

Shipment receipt

The purchaser should examine the shipment upon receipt. **Freedom Medical** must be notified by the purchaser within 30 days of invoice of any short shipment, or any order-mistake.

Apparent shipment damage must be noted on delivery receipt and notified immediately to **Freedom Medical**. A claim in the amount of replacement cost will be initiated with the carrier for the damages incurred. If any damage is found, the purchaser must notify **Freedom Medical** within 15 days of shipment receipt.

Product return

Merchandise cannot be returned without approval from **Freedom Medical**. An authorization number will be provided which must be printed on the packaging of the returned merchandise. Special, modified or discontinued products not subject to return.

Limited warranty

Freedom Medical warrants to the original purchaser that the products shall be free structural defects in material and workmanship for a determined period after date of delivery; refer to the purchase documentation for information about the available warranty time periods. **Freedom Medical**'s obligation under this warranty is expressly limited to supplying replacement parts and/or service for, or replacing, at its option, any product that is, in the sole discretion of **Freedom Medical**, found to be defective. In addition, **Freedom Medical** warrants for life to the original purchaser that the welds on its products will be free from structural defects.

Any repair using non-authorized or non-original parts and any product alteration or modification will void this warranty.

Parts and service

Original service parts are available for the lifetime of the product. Contact **Freedom Medical** at:

Freedom Medical Inc.
219 Welsh Pool Road
Exton PA 19341, UNITED STATES
T: (800) 784-8849
bedservice@freedommedical.com

INDEX

A

Angle indicator 6

Auxiliary power outlet 6, 8, 21, 28

B

Backlight 13

Backrest 7, 21, 27, 31, 32, 33, 34, 36, 37

Bed exit 5, 23, 26, 27

Bed extender 6, 30

Brake, neutral and steer 6, 25

Bumper 6, 7, 26

C

Caregiver siderail control 34

Cleaning 18, 59

CPR release 6, 17, 27

D

Disinfection 59

Display screen 16, 23, 26, 36

Drainage bag support 6, 25

E

EMC 9

F

Footboard 6, 29, 35

Footboard control 6, 23, 35, 36

Frame control 6

H

Headboard 6, 35

I

Integrated pump holder 35

IV pole 49, 50, 51

M

Motion lockout 36

N

Nightlight 29

Nurse call 21, 23, 27, 32

O

Oxygen bottle holder 53

P

Patient helper 54

Patient restraint location 6, 26

Patient siderail control 6, 32

Pendant control 55

Power cord 6, 27

Product description 5

Product illustration 6

Product intended use 5

S

Scale 5, 8, 21, 23, 48

Siderail control 6

Siderail release handle 31

FREEDOM MEDICAL

Freedom Medical Inc.

219 Welsh Pool Road
Exton, PA 19341
UNITED STATES

800-784-8849